

The **Wireless**
AND
RADIO REVIEW **World**

VOLUME XXIII

JULY 4th—DECEMBER 26th, 1928

ALL RIGHTS RESERVED

Published from the Offices of "THE WIRELESS WORLD"
ILIFFE & SONS LTD., DORSET HOUSE, TUDOR ST., LONDON, E.C.4

INDEX—VOLUME XXIII

JULY 4th—DECEMBER 26th, 1928

- A.B. Products—H.F. Choke, 774
Abroad, Programmes from, 15, 45, 73, 105, 135, 169, 197, 227, 257, 283, 319, 365, 393, 468, 505, 533, 565, 601, 635, 673, 713, 733, 761, 797, 820, 860
—, Programmes from (Editorial), 1
—, Sets for, 808
Accumulator Carrier, Weston, 564
Charging, 489
—, Discharge, Equalising, 272
—, Knobs, Clix, 112
—, or Eliminator? 750
Accumulators, House-lighting, 240
—, H.T., 240
—, ? Mains or, 582
A.C. Eliminator, Choosing an, 450
—, Filament Heating, 240
—, Gramophone Amplifier, 756
—, In Favour of (Some Useful Hints), 232
—, Interference, Eliminating, 148
"Aconical" Cabinets, 112
A.C. Receiver, An All-wave, 272
"A.C.3" Receiver, 274, 692
"A.C.2," 214
A.C. Valve Problem, An, 27
—, Valves, 691, 750, 807
Advance Three-valve Portable, The (Broadcast Receivers), 68
Advertise Programmes? Should the B.B.C. (Editorial), 809
Aerial and its Electric Field, The, 141
—, Coupling, A New, 65
—, Down Lead, The, 867
—, Earth Connections, 548
—, Mast, Fixing the, 9
Aerials, Directional, 151
—, Indoor, 27
Aerial Tuner, New Two-range, 837
—, Tuning Condenser, The, 152
Aermonic Barthing Switch, 174
Allocation of Wavelengths for Broadcasting (Editorial), 751
All-wave A.C. Receiver, An, 272
—, "Four," The, 28, 720
—, "Four," The New, 13, 212
—, H.F. Unit, An, 151
—, Tuner, 510
Aluminium Cabinets, "Stella," 140
—, Panels, Finishing Copper or, 142
Amateur-band Wavemeter, 537
Ammeter, Milliamps on an, 88
Amplification Limit, 328
Amplifier Input Connections, 760
Anode Bend for Volume, 691
—, Feed Resistances, "Berclit," 72
—, Resistance, Lissen, 173
—, Resistances and Short Waves, 692
Anti-capacity Switches, Wearite, 688
—, Valve Holder, Pyc, 41
—, Interference Unit, Dubiller, 19
—, "Mobo," R.I. Varley, 261
Apparatus, New, 41, 112
Argentine Amateurs, 390
Armchair Wireless, 81
Australia, Broadcasting Changes in, 131
Australian Broadcasting Stations, 207
Automatic Tuner, 20
- Back-coupling in Eliminators, 381
—, Coupling through Phone Leads, 272
Ballot Result of Olympia Competition, 703
Baseboard Neutralising Condenser, Bulgin, 41
Battery Chargers (No. 281,306), 22
—, Lead, A Novel, 33
Batteryless Receiver for D.C. Mains, A (D.C.), 60
Battery Receiver Unit, A (No. 290,350), 754
—, Resistance, 152
—, Testing (No. 285,622), 132
B.B.C. and Television, The (Editorial), 549
"B.B.C." Cabinet Battery," 509
—, Control Room, The (Editorial), 523, 583
"Beam" Cone Loud Speaker Unit, 533
"Berclit" Anode Feed Resistances, 72
Berlin Show, Impressions of the, 306
Bias for A.C. Valves, 691
Bias for Screened Valves, 651
Binocular Choke, McMichael, 687
Books Received, 256, 282, 387, 502, 572, 658
Book Reviews, 387, 629, 819
- Brayton Trickle Charger, The, 688
Bright Emitters as Rectifiers, 183
British Acoustic Film System, The (Talking Films), 842
—, Photophone System (Talking Films), 792
Broadcast Brevities, 23, 51, 85, 117, 143, 177, 203, 233, 268, 296, 323, 363, 445, 481, 515, 543, 573, 599, 641, 682, 711, 745, 772, 805, 832, 865
Broadcasting Monopoly, The (Editorial), 185
—, Scientific Foundations of, 728
—, Stations, 206
Broadcast Receivers, 68, 175, 503, 776
—, Reception, Directive, 659
Brown "L.F." Transformer, 639, 744
"Bulgin" Baseboard Neutralising Condenser, 41
—, "Safety Fuse Holder, 836
Burndept Electric Sound Box, 234
—, H.F. Choke, 510
—, Wander Plugs, 112
Buyers' Guide, 1923-29, 663
Buzzer or Heterodyne? 652
- Cabinet, A Fabric-covered, 71
—, "Battery, B.B.C., 509
—, Loud Speaker, Ormond, 71
Cabinets, Smith's, 837
Cabinet Type Receivers (Buyers' Guide), 663
Cables, Wireless and, 168
Canadian Broadcasting Stations, 207
Capacity Effects, 212
Car Battery, The, 622
Cason Valve Holders, 510
Catalogues Received, 20, 42, 140, 278, 355, 510, 564, 658, 700
Ceylon, Broadcasting Stations in, 207
Change-over, A Quick, 28
Changing Over, 522
Charge-Discharge Meter, A, 867
Charging, Accumulator, 499
Charts, Useful Data, 38, 82, 110, 126, 158, 204, 252, 294, 360, 388, 483, 500, 580, 596, 648, 680, 717, 789, 834, 864
Choosing a Circuit, 522
Christmas and Radio (Editorial), 779
—, Radio Gifts for, 780
Circuit Diagrams, Reading, 246
Circuits, Simplifier, 741
Climax H.F. Choke, 639
Clix Accumulator Knobs, 112
Club News, 21, 37, 84, 116, 196, 288, 355, 392, 520, 547, 560, 592, 634, 686, 702, 732, 766, 786, 817
Coil Drive Loud Speaker, Marconiphone, 203
Coil Winding Hint, A, 457
Colvern Six-pin Base, 825
Commercial Wireless, A Year's Progress in, 801
Common-wave Broadcasting in Germany, Experiments on, 554
Competition, Olympia Show, *The Wireless World*, 301, 330, 371, 460, 491, 623
—, Olympia Show, *The Wireless World*, Results, 624, 703
Compromise in Receiver Design, 91, 127, 163, 189, 242, 289
Condenser Insulation, 548
Cone Loud Speaker Unit, "Beam," 538
Connections, Testing, 27
Continental Programmes, 15, 45, 73, 105, 135, 169, 197, 227, 257, 283, 319, 365, 393, 468, 505, 533, 565, 601, 635, 673, 713, 733, 761, 797, 820, 860
Control Room, The (Editorial), 121
Copper or Aluminium Panels, Finishing, 142
Copper Wire, The D.C. Resistance of (Useful Data Charts), 360
Corrected L.F. Amplifier, A, 28
Correspondence, 26, 36, 86, 119, 149, 181, 209, 239, 270, 298, 326, 369, 447, 487, 519, 530, 576, 620, 650, 689, 747, 777, 794, 838
Cossor Screened Grid Valve, S.G., 220, 767
Coupling by Grid Leak and Condenser, Efficiency of (Useful Data Charts), 618
Courtney Flight, Wireless on the, 270
Crystal and Pentode, 692
—, Another Use for the, 652
—, Detector, A Suggested Explanation of the, 629
Crystal Holder, Piezo (No. 277,330), 754
—, Set, A Short-wave, 152
- Current Topics, 11, 43, 69, 100, 133, 167, 195, 231, 255, 287, 317, 359, 391, 472, 503, 531, 581, 637, 633, 661, 701, 727, 765, 795, 818, 850
"Cyanite," 688
Cyclon Synchronate Twin Condensers, 743
- Damped but Distortionless, 740
Davex Eliminator, 10
—, Tuners, 564
"D.C.5," A Batteryless Receiver for D.C. Mains, 60, 97, 300
D.C. Mains Receivers, 221
—, Resistance of Copper Wire, The (Useful Data Chart), 360
—, Resistance of Resistance Wire (Useful Data Chart), 388
Deaf, Aid to the, 448
"Decoupling" a Screened Valve, 548
—, Incorrect, 522
"De-coupling" Tip, A, 211
Defective Winding, A, 490
Detection and Signal Strength, 183
Detector, An Unstable, 211
Detector Bias, Determining, 212
—, Fading and the, 45
—, Screened Grid Valve as a, 492
—, The Choice of a (Compromise in Receiver Design), 127
—, Underloading a, 548
"Devicon" Condenser, A New, 42
Diameter of Wire or Strand to give Coil of Minimum H.F. Resistance (Useful Data Charts), 834
—, of Wire to give Coil of Minimum H.F. Resistance (Useful Data Charts), 864
Differential Reaction, 720
Dimic Three, The Screened (Broadcast Receivers), 175
Diode, The Distortionless, 783
Direct Coupling System, A (No. 289,217), 598
Directional Aerials, 151
—, Directional Signalling (No. 285,169), 132
Direction Finder for the Experimenter, Radio, 186, 247
Directive Broadcast Reception, 659
Discharge Rates, 750
Disconnected Grid, A, 211
Distortionless Detection, 652
—, Diode, The, 783
"Doric" Cabinets, 564
Double-acting Reed Unit, 262
—, Capacity H.T. Battery, Ripault, 640
Dropping Volts! 724
Dry Batteries are Better, When, 454
—, Cell H.T. Batteries, 815
Dual Impedance Coupling, 775
Dublier Anti-Interference Unit, 19
—, Components, Two New, 509
- Earthing Switch, Aermonic, 174
—, Tube Connection, 9
Earth System, The, 807
"Ebonart," Redfern's, 509
Ebonite? Wood or, 582
Echoes from the Depths of Space, 722
Eckersley, Captain P. P. Reminiscences of, 376
Editorial, 1, 29, 59, 89, 121, 153, 185, 213, 241, 273, 301, 329, 371, 449, 491, 523, 549, 583, 623, 653, 683, 721, 747, 751, 779, 809, 841
Edward's Unspillable Accumulator, 72
Elex Earth, 262
Electric Field, The Aerial and its, 141
—, Sound Box, Burndept, 234
—, Supply Mains, Valve Current from, 213
Electricity Supply Companies, Mains, Units, and, 319
—, Supply Ramp, An (Editorial), 29
Eliminating A.C. Interference, 148
—, Morse Interference, 868
Eliminator Breakdown, An, 212
—, Megavox, 757
—, Ohm's Law and the, 490
—, or Accumulator? 750
Eliminators, Back-coupling in, 381
Emission, Lost, 58
Empire Broadcasting (Editorial), 583, 693
"Empire" Receiver, The New, 854
—, Set on 150 Metres, The, 521

A-12119

PROPERTY OF THE U.S. AIR FORCE

- Energising Current, 778
 Equalising Accumulator Discharge, 272
 Europa III. The, 691, 737
 European Broadcasting Stations, 206
 "Everyman Four" on a Frame Aerial, The, 370
 "Portable" Circuit, The, 778
 Exhibition at Olympia, Index to, 357
 Expanding Screwdriver, 205, 293
 Experimental Licences, New Conditions for, 318
 Exponential Horn, Folded, 140
 Extension for Telephones on Loud Speaker Set, 251
 Extra H.F. Stage, An, 522
- Fabric-Covered Cabinet, A, 71**
 Fading and the Detector, 485
 —, Spurious, 521
 Far South. Wireless Telephony in the, 145
 Ferranti Triple Range Meters, 139
 Filament Heating, A.C., 240
 Filaments, Mains-fed, 240
 Filament Wattage, 868
 Films, Talking, 792, 842
 Five Metres. Experiments on, 453
 58W Experimental (Editorial), 583
 Fixed Condensers, Magnum, 234
 — Condensers, Trix, 173
 Flat Tuning, 692
 — Tuning, Grid Detection and, 867
 Flux, Non-Corrosive, 212
 Folded Exponential Horn, 140
 Four-Electrode Valves (No. 285,975), 67
 "Four-Point" Condenser, Newey, 19
 "Frame Aerial, Long Wave, 448
 — Aerial Switching, 28
 — Aerial, The "Everyman Four" on a, 370
 "Fultograph," The, 555
 Future? What of the (Editorial), 449
- Gambrell Volunternia, 852**
 G.B. Battery, Siemens, 203
 Gifts for Christmas, Radio, 780
 "Gold Wave" Aerial, 658
 Graham-Farish Grid Leak Base, 112
 Gramophone Amplifier, A.C., 755
 Graves "Vulcan" Two (Broadcast Receivers), 776
 Grid, A Disconnected, 211
 — Bias for H.F. Valves, 300
 — Bias, Short-circuited, 88
 — Circuit Modification, A, 692
 — Detection and Flat Tuning, 867
 — Leak Base, Graham Farish, 112
 — Swing with a Pentode, Permissible, 584
 Guide to the Show—A Forecast of Olympia, 339
- Harlie Components, New, 563**
 Wave Selector, 744
 Bartley Circuits, Switched, 750
 Hay's Radio Wax, 837
 Headphones, Reception on, 868
 Heterodyne, Buzzer or, 652
 H.F. Amplification, Reducing, 840
 — Amplification, Stabilised (No. 283,497), 844
 — Amplifier, A Stabilised (No. 286,901), 268
 — Amplifier Design, Further Notes on (Compromise in Receiver Design), 289
 — Amplifier, The (Compromise in Receiver Design), 242
 — and L.F. Chokes, 522
 — and Reinartz, 490
 — Choke, A.B. Products, 774
 — Choke, Climax, 639
 — Choke, Irganic, 836
 — Chokes, 370 372
 — Choke, "Tayloradio," 852
 — Currents in the Phone Leads, 489
 — in the L.F. Amplifier, 651
 — Oscillator, The Simplest, 749
 — Potentiometer, An, 622
 — Stage, An Extra, 522
 — Transformers, Building, 455
 — Transformers for A.C. Valves, 807
 — Transformers, Modified, 867
 — Unit, An All-Wave, 151
 — Unit for the New "R.C. Threesome," 139
 — Valves, Grid Bias for, 300
- High Anode Voltages, The Use of, 791**
 Frequency Resistance, 810, 845
 — Note Loss, 151
 — Resistances, Variable (No. 284,770), 22
 Holland's New Example (Editorial), 809
H.T. Accumulators, 240
 — Batteries, Dry Cell, 815
 — Batteries, Longer Life for, 656
 — Batteries, Noisy, 720
 — Extension Leads, 370
 — Supply, A Safe, 768
 — Units, Tudor, 564
 — Voltage, Reduced, 582
- "Ideal" Condenser, Polar, 205**
 I.E.E. Regulations, New (Mains Connected Receiving Sets), 87
 Irganic H.F. Choke, 836
 Three-valve Short-wave Set (Note), 42
 Impedance and Input, 300
 — of a Moving-coil Loud Speaker, The, 729
"Imperial" Volume Control, 174
- Independent Volume Control for Several Loud Speakers, 180**
 India and Ceylon Broadcasting Stations in, 207
 Indoor Aerials, 27
 — Aerial Tip, An, 58
 Inductance, Capacity and Frequency (Useful Data Charts), 82, 110, 126
 Input, Impedance and, 300
 Inter-circuit Coupling, 211
 Intervalve Transformers (No. 287,191), 179
 Inventions, Recent, 22 67, 132, 179, 208, 598, 751, 814
- Japanese Broadcasting Stations, 207, 662**
Japanese Broadcasting Stations, 207
 Jannens Components, 510
- Kilo-Mag, Four, The, 550, 558**
 — Mag, Four, The (Readers' Problems), 720
- Laboratory Tests, The Wireless World, 19, 71, 139, 178, 205, 234, 261, 293, 325, 509, 537, 563, 639, 687, 743, 774, 836, 852**
 Leaky Grid Condenser, A, 521
 Leclanché L.T. Battery, "Standard," 853
 Letters to the Editor, 26, 56, 86, 119, 149, 181, 209, 239, 270, 298, 326, 369, 447, 487, 519, 530, 576, 620, 650, 689, 747, 777, 794, 838
 Lewcos H.F. Choke, 537
 Lewis Expanding Screwdriver (A Correction), 293
L.F. Amplification, Tuned, 489
 — Amplifier, A Corrected, 28
 — Amplifier, H.F. in the, 651
 — Amplifier, Scientific Design of the, 189
 — Amplifier, The (Compromise in Receiver Design), 163
 — Stability Assured, 300
 — Switching, 750, 849
 — Transformer, Brown, 639, 744
 — Transformer, Testing an, 28
 "Liberty" Superhet, A New, 20
 Lightning Arrestor, Philips, 71
 Light-sensitive "Pick-ups" (No. 288,711), 598
 Lissen Anode Resistances, 173
 — Variable Condensers, 538
 Litz, A Substitute for, 88
 Long-Wave Frame Aerial, 448
 — Wave Instability, 868
 — Wave Reaction, 272
 Loose-Coupling, 10
 Loricadaptor, The, 112
 Lotus Miniature Valve Holder, 538
 Loud Speaker, A Distant, 184
 — Speaker Resonance, 300
 — Speakers (No. 281, 634), 179
 — Speakers (No. 290,344), 754
 — Speakers (No. 288,386), 814
 Lower Frequencies, Suppressing, 151
 Low Loss Superfluous, 803
 — Magnification Stage, A, 518, 508
 L.S.A. Wet H.T. Cell, 262
- Magnum Fixed Condensers, 234**
 — "Vibro" Holders, 261
Mains Connected Receiving Sets (New I.E.E. Regulations), 87
 — Equipment, Types of, 235
 — Fed Filaments, 240, 300
 — or Accumulators? 582
 — Supply Units (Editorial), 623, 693
 — Transformer Design, 569, 630
 — Units and Electricity Supply Companies, 310
 Manchester Radio Show, 545, 578, 605
 Marconi and Osram Power Valves (Valves We Have Tested), 684
 — Patents (Editorial), 273
 Marconiphone Coil Drive Loud Speaker, 293
 — "Popular" Transformer, 852
 — Short-Wave Set (Broadcast Receivers), 593
 — Variable Condensers, 174
 McMichael Binoocular Choke, 687
 "Megavox," A Portable, 749
 — Coils, Wearite, 640
 — Eliminator, 787, 827
 — The, 331, 385, 458
 — The (Reader's Problems), 840
 — Three," Pedestal Cabinet for the, 775
 Megger, An Improvised, 120
 — Rectifiers, 223
 — Rectifier, Theory of the, 824
 Metal Rectifiers (No. 283,901), 208
 Milliammeter, Increasing the Range of a, 370
 Milliamps on an Ammeter, 88
 — on a Voltmeter, Reading, 720
 Miniature Condensers, Peto-Scott, 174
 — Valve Holder, Lotus, 538
 Minimum H.F. Resistance, Diameter of Wire or Strand to give Coil of (Useful Data Charts), 834
 Mobile Transmitter, Tracking a, 166
 Modulator, A Photo-Electric (No. 266,288), 208
 Momentary Oscillation, 840
 Monopoly, No (Editorial), 523
 Monotone Power Valve, 261
 Morse Interference, Eliminating, 868
 — Learning, 183
 Motor-boating, 749
- Moving-Coil Loud Speakers, Resonance in, 497, 530**
 — Coil Loud Speaker, The Impedance of a, 729
 — Coil Modifications, 122
 — Coil Supports, 375
 — Coil, The Output Stage and the, 154
 — Coil with 2,500 Turns, Winding a, 353
 Mullard P.M. 4D (Valves We Have Tested), 96
 — P.M. 12 (Valves We Have Tested), 25
 Multilayer Coils, Self-inductance of (Useful Data Charts), 769
 Multiple-Unit Valve Sets (No. 274,901), 22
 Multi-stage Valve, Selective (No. 261,013), 132
 "Negative," Too Much, 184
 Negligible Resistance, 418
 Neutralise, How to, 867
 Neutralising and Sensitivity, 490
 "New All-Wave Four," The, 13, 28, 212
 New Apparatus, 41, 112
 — Empire Receiver, The, 854
 Newey "Four-point" Condenser, 19
 — "New Lamps for Old," 496
 — Zealand Amateurs, 572
 — Zealand Broadcasting Stations, 207
 Noisy H.T. Batteries, 720
 Non-Corrosive Flux, 212
 North and East African Broadcasting Stations, 207
 Novelties from Our Readers, 9, 251
 N.S.F. Products, 563
- Ohm's Law and the the Eliminator, 490**
 — Law Again, 448
 Oldham H.T. Units, 20
 Olympia, A Forecast of, 339
 — Further Gleanings from, 473
 — Index to Exhibitors at, 357
 — Lessons from, 577
 — 1928, 329, 371, 397
 — Show Competition, *The Wireless World*, 301, 530, 371, 460, 491, 623
 — Show Competition, *The Wireless World*, Results, 624, 703
 — Stand to Stand Report, 399 et seq.
 Ormond Cabinet Loud Speaker, 71
 Oscillation, Momentary, 840
 Osram Power Valves, Marconi and (Valves We Have Tested), 684
 Output Stage and the Moving Coil, The, 154
 — Stage and the Pentode, The, 30, 77, 113
 — Stage, The (Compromise in Receiver Design), 93
 Overloaded Eliminator, An, 778
 Overloading, Volume Controls and, 384
 Over-running a Valve, 88
- Parallel Feed, 370, 489**
 — Output System, A, 152
 Paris Radio Show, 623, 643
 Patent Difficulties (Editorial), 153
 — Law Reform (Editorial), 653
 Patents, Marconi (Editorial), 273
 — Recent, 22, 67, 132, 179, 205, 598, 754, 814
 Pedestal Cabinet for the "Megavox Three," A, 775
 Peerless Valve Holder, 205
 Pentode Connections, 749
 — Crystal and, 692
 — Fitting a, 608
 — or Triode, 652
 — Permissible Grid Swing with a, 584
 — Quality Three, The, 115
 — The, 7, 116
 — The Output Stage and the, 30, 77, 113
 — Three, Screened Grid and (A New Receiver), 302
 "Pentode Two," 524
 Peto-Scott Miniature Condensers, 174
 Philips Lightning Arrestor, 71
 Phone Leads, Back Coupling Through, 272
 — Leads, H.F. Current in the, 489
 Photo-electric Modulator (No. 266,288), 208
 Phototone System, British (Talking Films), 792
 Pick-up, A Sensitive, 867
 — Carrier, Watmel, 775
 "Pick-ups," Light-sensitive (No. 288,711), 598
 Picture Broadcasting (Editorial), 89, 241
 — Broadcasting and News Pictures, 377
 — Receiver, An Hour with a, 752
 — Reception, 521
 Piezo Crystal Holder (No. 277,330), 754
 P.M.4D, Mullard (Valves We Have Tested), 96
 P.M.12, Mullard (Valves We Have Tested), 25
 Pocket Soldering Outfit, A, 688
 Polar "Ideal" Condenser, 205
 "Popular" Transformer, Marconiphone, 852
 Portable and Self-contained Sets (Buyers' Guide), 668
 — "Megavox," 749
 — Transmitter, 501
 Postlethwaite Coils, 774
 Potentiometer, An H.F., 622
 —, Selectivity and the, 692
 Problems, Readers', 27, 58, 88, 120, 151, 183, 211, 240, 272, 300, 328, 370, 445, 489, 521, 548, 582, 622, 651, 691, 720, 749, 778, 807, 840, 867

- Programmes from Abroad, 15, 45, 73, 105, 135, 169, 197, 227, 257, 283, 319, 365, 393, 468, 505, 533, 565, 601, 635, 673, 713, 733, 761, 797, 820, 860
- from Abroad (Editorial), 1
- Should the B.B.C. Advertise the (Editorial), 809
- Progress, The Trend of, 59, 461, 511
- Push-pull or Parallel? 807
- Pitfall, A, 170
- Pye Anti-capacity Valve Holder, 41
- Pye Transformer, A New, 837
- Quality Reception, 807**
- Three, The Pentode, 115
- “Q” Code, Modifications of, 254
- Queries, Readers', 27, 58, 88, 120, 151, 183, 211, 240, 272, 300, 328, 370, 448, 489, 521, 548, 582, 622, 651, 691, 720, 749, 778, 807, 840, 867
- “R” Code, 595
- Radio Gifts for Christmas, 730
- Tester, Weston, 42
- What Do They Know of, 477
- “R.C. Threesome,” H.F. Unit for the New, 139
- Reactance of a Coil at Audio Frequencies, The (Useful Data Charts), 158
- of a Coil at Radio Frequencies, The (Useful Data Charts), 204
- of a Condenser at Audio Frequencies (Useful Data Charts), 252
- of a Condenser at Radio Frequencies (Useful Data Charts), 294
- Reaction Condenser Capacity, 582
- Control (No. 286,578) 67
- Control, Poor, 27
- Differential, 720
- Failure, A, 807
- is Unnecessary, Where, 490
- its Uses and Abuses, 517
- Throttle Control of, 88
- Readers' Novelties, 9, 251
- Readers' Problems, 27, 58, 88, 120, 151, 183, 211, 240, 272, 300, 328, 370, 448, 489, 521, 548, 582, 622, 651, 691, 720, 749, 778, 807, 840, 867
- Reading Circuit Diagrams, 246
- Milliamps on a Voltmeter, 720.
- “Realistic” Loud Speaker, 687
- Receiver Design, Compromise in, 91, 127, 163, 189, 242, 289
- Records and Radio, 651
- Red Diamond Switch, 234
- Redfern's “Ebonart,” 509
- Red-hot Valves, 300
- Reinartz, H.F. and, 490
- Relay Station Changes, 292
- Trouble with a, 58
- Resistance, An Excessive, 691
- Charging a, 651
- Negligible, 448
- Wire, The D.C. Resistance of (Useful Data Charts), 388
- Resistances in Parallel, The Value of (Useful Data Charts), 483
- Resonance in Moving-coil Loud Speakers, 497, 539
- Ripault Double Capacity H.T. Battery, 640
- Variable Condenser, 262
- R. I. Varley “Anti Mobo,” 261
- Rubber Sheet, Pure, 640
- Safe H.T. Supply, A, 768
- Safety First for Mains Users, 220
- Fuse Holder, “Bulgin,” 836
- Salon de T.S.F. (Review of Paris Show), 643
- Science Museum, At the, 49
- Scientific Design of L.F. Amplifier (Compromise in Receiver Design), 189
- Foundations of Broadcasting, 728
- Screened Dime Three, The, 157
- Grid and Pentode Three (A New Receiver), 392
- Grid Valve as a Detector, 492
- Valve “Decoupling, A, 548
- Valves, Bias for, 651
- Screening Still Necessary, 328
- Screwdriver, Expanding, 205, 293
- Selective Multi-stage Valve (No. 261,013), 132
- Selectivity and Screening, 480
- and the Potentiometer, 692
- Diminishing, 152
- Improving, 328
- Self-contained Sets, Portables and (Buyers' Guide), 668
- Self-inductance of Multilayer Coils (Useful Data Charts), 769
- Self-inductance of Solenoids (Useful Data Charts), 717
- Sensitivity, Neutralising and, 490
- Series Condensers, 120
- S.G.230, Cosor Screened Grid Valve (Valves We Have Tested), 767
- S.G. Valves, Transformer Coupling with, 808
- Ship Stations, Short Wave, 160
- Short-circuited Grid Bias, 88
- Mains, 652
- Short-wave Adaptor, S.R.S., 173
- Attachment, A, 58
- Band; Inductance, Capacity and Frequency (Useful Data Charts), 82
- Crystal Set, A, 152
- Reception, 489
- Ship Stations, 160
- Short-Wave III,” For the, 490
- Siemens G.B. Battery, 293
- L.T. Battery for the Evermay Portable, 140
- Signalling, Directional (No. 285,169), 132
- Signal Measurements, 40
- Strength, Detection and, 183
- Lost, 323
- Unit, A Territorial, 575
- Simplified Circuits, 741
- Six-pin Base, Colvern, 325
- Smith's Cabinets, 837
- Soldering Outfit, A Pocket, 688
- Solenoids, Self-inductance of (Useful Data Charts), 717
- Sound Box, Burndept Electric, 234
- South African Broadcasting Stations, 207
- American Amateur Stations, 502
- American Broadcasting Stations, 207
- Space, Echoes from the Depths of, 722
- Spade Ends, The Construction of, 251
- S.P.16 Series of Met-Vick Valves, The (Valves We Have Tested), 529
- S.R.S. Short Wave Adaptor, 173
- Stabilised Amplifiers (No. 285,229), 180
- H.F. Amplification (No. 288,497), 814
- H.F. Amplifier, A (No. 286,891), 208
- Stal Valves, 325
- Standard Four, Testing a, 103
- “Standard” Leclanché L.T. Battery, 853
- Stand to Stand Report, Olympia, 399, et seq.
- “Stella” Aluminium Cabinets, 140
- Cabinets—A New Finish, 639
- Sure-a-Lite “Supra” Battery, 72
- Switched Hartley Circuits, 750
- Switching, Complicated, 651
- Switching Out an L.F. Stage, 849
- Waveband, 625
- Switch-over, Two Station, 868
- “Switch-over Three” 2, 34, 184
- Synchratone Twin Condensers, Cydon, 743
- Talking Films, 779, 792, 842**
- Tantalum Rectifier, A, 184
- “Tayloradio” H.F. Choke, 852
- Telephones on Loud Speaker Set, Extension for, 251
- Telephony in the Far South, Wireless, 145
- Television Apparatus (No. 288,822), 598
- A Promise, 6
- (No. 207,643), 179
- The B.B.C. and (Editorial), 549
- Territorial Signal Unit, A, 575
- Testing Connections, 27
- Three-Base, Trix, 41
- Valve Portable, The Advance (Broadcast Receivers), 65
- Valve Short-Wave Set, Igranic (Note), 42
- Throttle Control of Reaction, 88
- Time Constant of Grid Leak and Condenser (Useful Data Charts), 680
- Tone-Raising Device, A, 807
- Tones, Current, 11, 43, 99, 109, 133, 167, 195, 231, 255, 287, 317, 359, 391, 472, 503, 531, 561, 587, 633, 661, 701, 727, 765, 795, 818, 850
- Tracking a Mobile Transmitter, 166
- Trade Notes, 20, 72, 355, 640, 775
- Transatlantic Success on 10 Metres, 201
- Transformer Construction, 490, 522
- Coupling with S.G. Valves, 808
- Design, Mains, 569, 630
- Materials, 744
- Transmission Quality (Editorial), 721
- Transmitter, Portable, 501
- Transmitters' Notes and Queries, 12, 53, 124, 160, 254, 305, 362, 390, 499, 532, 572, 595, 662, 702, 766
- Transmitting Permits, Revision of, 486
- Trend of Progress, The, 461, 511
- Trickle Charger, The Brayton, 688
- Triple Range Meters, Ferranti, 139
- Trix Fixed Condensers, 173
- H.F. Choke, 743
- Three-Base, 41
- T.S.F., Salon de (Review of Paris Show), 643
- Tudor H.T. Units, 564
- Tuned L.F. Amplification, 489
- Note Filter, A, 212
- Turns? How Many, 125
- Two Capacities in Series (Useful Data Charts), 500
- Range Aerial Tuner, A New, 837
- Range Four, 311
- Station Receiver, A, 750
- Station Switch-over, 868
- Underloading the Detector, 548**
- Unspillable Accumulator, Edwards', 72
- U.S.A., Broadcasting Stations in, 207
- Useful Data Charts, 38, 82, 110, 126, 158, 204, 252, 294, 360, 388, 500, 580, 596, 648, 650, 717, 769, 834, 864
- Data Charts, List of, 596
- Valve Characteristics, 212**
- Current from Electric Supply Mains, 213
- Data, 263
- Holder, Peerless, 205
- Valves, The New (Editorial), 241
- We Have Tested, 25, 96, 529, 684, 767
- Variable Condensers, Lissen, 538
- Condensers, Ripault, 262
- Condensers, Marconiophone, 174
- Condensers, Rebuilding, 840
- High Resistances (No. 281,770), 22
- “Vibro” Holder, Magnum, 261
- Voltage, Insufficient, 522
- Reading, A Misleading, 120
- Reducing Resistances, 720
- Volts, Ohms and Amperes, The Relation Between (Useful Data Charts), 580
- Wanted, 692
- Volume Control, 582
- Control for Several Loud Speakers, Independent, 150
- Control, “Imperial,” 174
- Controls and Overloading, 384
- Volvunna, Gambrell, 852
- “Vulcan” Two, Graves (Broadcast Receivers), 776
- Wander Plugs, Burndept, 112**
- War of the Future, Wireless in, 796
- Watmel Pick-up Carrier, 775
- Watts, Amperes and Volts, The Relation Between (Useful Data Charts), 590
- Waveband Switching, 625
- Wavelengths for Broadcasting, Allocation of (Editorial), 751
- Wavemeter, Amateur-Band, 537
- The Simplest, 194
- Wave Selector, Hartie, 744
- Wavetrap, The Best, 568
- Wax, Hay's Radio, 837
- Wearite Anti-Capacity Switches, 688
- “Megavox” Coils, 640
- Wire-Wound Condenser, 325
- Westminster, Wireless at, 44, 70, 168, 796, 819, 851
- Weston Accumulator Carrier, 564
- Wet H.T. Cell, U.S.A., 262
- What Do They Know of Radio Who Only Radio “Know” 477
- Wilderness, Wireless in the, 740
- Winding a Moving Coil with 2,500 Turns, 353
- Winding Coil (No. 286,047), 67
- Wired Wireless, Broadcasting by, 677, 698
- Wireless and Cables, 168
- at Westminster, 44, 70, 168, 796, 819, 851
- Operator, The (Editorial), 693
- Telephony in the Far South, 145
- Wireless World Laboratory Tests, 19, 71, 139, 173, 205, 234, 261, 293, 325, 509, 537, 563, 639, 687, 743, 774, 836, 852
- World Olympia Show Competition, 330, 371, 460, 703
- Wire-Wound Condenser, Wearite, 325
- Wood or Ebonite? 582
- Year's Progress in Commercial Wireless, A, 801**

ILLUSTRATIONS

- Abacs, A New Series of (Useful Data Charts), 38, 39, 83, 111, 126, 159, 204, 252, 253, 294, 295, 360, 389, 484, 500, 581, 597, 649, 681, 718, 719, 770, 771, 895, 864
- A.B. Products H.F. Choke, 774
- Absorption Wavemeter, G.R.C., 537, 538
- Wave-trap, Connections of (Diagram), 868
- Accumulator Carrier, Weston, 564
- A.C. Gramophone Amplifier, 753, 756, 757, 758, 759
- Acid Proof Accumulator Knob, Chix, 112
- “Aconicab” Mahogany Cabinet, 112
- Pedestal Cabinet for “Megavox Three,” 775
- A.C.3—A Long Range Quality Receiver, 274, 275, 276, 277, 278
- A.C.2, 214, 215, 216, 217, 218
- A.C. Valves, Bias for (Diagram), 691
- Advance Three-Valve Portable (Broadcast Receivers), 68
- Aerial and Its Electric Field, The, 111, 142
- Coupling, A New (Diagrams), 65, 66
- Mast Pivoted to Post, 9
- Aeromic Earthing Switch, 174
- Aircraft Transmitter, World's Most Powerful, 195
- AB Power Unit for D.C. Mains, Marconi, 236
- “All-wave” Tuner, Scott, 510
- Amateur Transmitter's Christmas Card, An, 819

- Amateur Transmitters in Conference, R.S.G.B., 562
- Amplifier Input Connections (Diagrams), 760
- Amplion "Lion" Loud Speaker, 339, 703
- Anode Feed Resistances, "Berclif," 72
- Anti-Capacity Switches, Wearite, 088
- Capacity Valve Holder, Pye, 41
- "Anti-Mobo" Unit, R.I.-Varley, 261
- Army Manœuvres, Wireless on, 317
- Automatic Tuner, Parts of the "Tunometer," 20
- Auto-Selector Set at Berlin Show, 308
- Back-Coupling** in Eliminators, 381, 382, 383
- Baffle, An Idea for a, 271
- Bakelite Bobbins, 744
- Battery Lead, A Tidy Multiple, 33
- Batteryless Receiver for D.C. Mains, D.C.5, a, 60, 61, 62, 63
- "B.B.C." Standard Capacity "Cabinet" H.T. Battery, 509
- Beam, Music by (Mr. G. A. Mathien), 23
- Unit and Accessories for Cone Loud Speaker Construction, 538
- "Berclif" Anode Feed Resistances, 72
- Berlin, Pictures from (President Hindenburg), 727
- Show, Exhibits at the, 306 et seq.
- Bias for A.C. Valves (Diagram), 691
- for Screened Valves (Diagram), 651
- Binocular Choke, McMichael, 687
- H.F. Choke, Climax, 369
- Bourne, Three-in-One Receiver by Mr. H. K., 134
- "Brayton" Trickle Charger, The, 688
- British Acoustic Film System, The (Talking Films), 842, 843, 844
- "Broadcasting House" (Portland Place), 772
- House" (Manchester Headquarters of B.B.C.), 118
- Broadcast Receivers; The Advance Three-Valve Portable, 68, 175, 176, 593
- Receivers, Graves "Vulcan" Two, 776
- Brown "Cubist" Moving Coil Loud Speaker, 340
- Moving Coil Loud Speaker Unit, 340
- Type "A" Intervalve Transformer, 640
- B.T.H. Junior R.K. Loud Speaker, 340
- Bulgin Baseboard Neutralising Condenser, 41
- "Bulgin" Safety Fuse Holder, 836
- Burndept Empire Screened Four, 340
- Gramophone Pick-up, 234
- H.F. Choke, Type No. 1,196, 510
- Pick-up, Magnet System of the, 234
- Wander Plug, 112
- Bypass Condensers Used in a Decoupling Scheme (Diagram), 522
- "Cabinet" H.T. Battery, "B.B.C." Standard Capacity, 509
- Cabinets, Smith's, 837
- Camping Joys, 224
- Cason Valve Holders, 510
- C.A.N. Low-tension Battery in Moulded Containers, 341
- 60-volt H.T. Accumulator Unit, 341
- Celestion Woodruffe Gramophone Pick-up, 341
- Charts, Useful Data, 38, 39, 83, 111, 159, 204, 252, 295, 361, 388, 389, 483, 500, 580, 581, 596, 597, 648, 649, 680, 717, 718, 719, 769, 834, 835, 864
- Choosing an H.T. Eliminator, 450, 451, 452
- Christmas Card, Amateur Transmitter's, 819
- Radio Gifts for, 750, 751, 752
- Circuit Diagrams, Reading (Diagram), 246
- Circuits, Simplified (How to Dissect a Theoretical Diagram), 741, 742
- Climax Binocular H.F. Choke, 369
- Clix Acid Proof Accumulator Knob, 112
- Coil Winding Composed of Folded Loops, Method of, 67
- Winding, Method of, 530
- Collapsible Cabinet, "Doric," 564
- Colvern Dual-range Coil, 312
- Six-pin Base, 325
- Commercial Wireless, A Year's Progress in, 801, et seq.
- Compromise in Receiver Design, 91, 92, 94, 127, 128, 129, 163, 164, 165, 166, 180, 190, 191, 192, 243, 244, 245, 289, 290, 291
- Concealed Transmitter, Hunting A, 21
- Cone Loud Speaker Construction, Beam Unit and Accessories, 538
- Courad, Dr. Frank (Film Transmission in America), 481
- Cook "Portable Five" Receiver, 342
- Copenhagen Broadcasting Station (Evolution in Studio Design), 682
- Copper Wire, D.C. Resistance of (Useful Data Charts), 361
- Cosson S.G.220 (Valves We Have Tested), 767
- Coupling by Grid Leak and Condenser, Efficiency of (Useful Data Charts), 648, 649
- Courtney Flight, Wireless on the, 279, et seq.
- Curry's, Ltd., Two Typical Receivers, 342
- Cydon "Synchratone" Twin Condensers, 743, 744
- Danish Amateur Station, A (Jorgen Prior, Hellemp), 362
- Davex Eliminator for 5GB, 19
- Tuner Units, 564
- D.C.5, 97, 98, 99, 100, 101, 102
- D.C.5, A Batteryless Receiver for D.C. Mains, 60, 61, 62, 63
- D.C. Supply from Output Mains, Diagram (Longer Life for H.T. Batteries), 686
- Mains Receivers (Diagrams), 221, 222
- Resistance of Copper Wire (Useful Data Charts), 361
- Resistance of Resistance Wire, The (Useful Data Charts), 388, 389
- Deaf, Aid to the (Diagram), 448
- Denmark's Capital, 744
- Detector Circuit with Throttle-controlled Reaction (Diagram), 521
- , Screened Grid Valve as a (Curves), 492, 493, 494
- , The Choice of a (Compromise in Receiver Design), 127, 128, 129
- "Devicon" S.L.F. Condenser, 42
- Diameter of Wire or Strand to give Coil of Minimum H.F. Resistance (Useful Data Charts), 834
- of Wire to give Coil of Minimum H.F. Resistance (Useful Data Charts), 864
- Differential Reaction, Short-wave Detector with, 720
- Dimic Three, The Screened (Broadcast Receivers), 175, 176
- Diode as Rectifier (Diagram), 689
- Detector, A (Diagram), 652
- Rectifier, Circuit Employing, 621
- , The Distortionless (Diagrams), 783, et seq
- Direct Coupling System, Circuit of, 598
- Direction Finder, Radio, 186, 247
- Directive Broadcast Reception, 659, 660
- "Doric" Collapsible Cabinet, 564
- Domier Napier, Captain Courtney's Flying Boat, 43, 44
- Double-acting Reed Unit, Goodman's, 262
- Double Horn Loud Speaker with Centrally Slotted Sound Box (Diagram), 814
- Dropping Volts! 724, et seq
- Dry Cell H.T. Batteries, 815, 816, 817
- Dual Impedance Coupling Unit, Irganic, 775
- Dubbilier Condensers, A Group of, 238
- C.R.I. Unit, 19
- Triple-gang Condenser, 343
- "Dumetohm" Holder and Combined Coupling Unit, 509
- Dunham Battery Eliminator, 343
- Earthing Switch, Aeronomic, 174
- Earthing Tube Connections, 9
- Echoes from the Depths of Space, 722, 723
- Ediswan Type "C" H.F. Unit for "R.C. Three-some," 130
- Edwards' Unspillable Accumulator, 72
- Eleex Filtered Earth Plate, 292
- Etesca "Screen Three," 343
- "Eko" Mains-drive 3-valve Receiver, 344
- Electrolyte Level Indicator for Accumulators, 132
- "Elettra" Transmitter on the, 12
- Eliminator for 5GB, Davex, 19
- , Megavox, 787, et seq., 827, et seq.
- Eliminators, Back-coupling in, 381, 382, 383
- "Elliott" Automatic Radio Exchange, 340
- "Empire" Receiver, The New, 654, et seq.
- "Ento" Cabinet Loud Speaker, 71
- Europa III, The, 694, 695, 696, 697, 737, 738, 739
- Everyman Portable, The, 26, 778
- Exhibition, Plan of Olympia, 357, 398
- Exhibits at Manchester Radio Show, pp. 605 to 620
- at Olympia Exhibition, 309, et seq., 473, et seq.
- at the Berlin Show, 306, 367, 308, 309
- Exide H.T. Trickle Charger, 344
- Exide W.T.10 H.T. Accumulator (Ballot Result), 707, 708
- Expanding Screwdriver, 205
- Far South, Wireless Telephony in the, 145, et seq
- Perranti Broad Rolled Foil Condenser, 344
- H.T. Eliminator, 345
- Triple Range Voltmeter, 139
- Field Magnet, Two-gang designs, 280
- Field Set, A Territorial, 706
- Film Transmission in America (Dr. Frank Conrad), 481
- Films, Talking, 792, et seq., 842, et seq.
- Five Metres, Experiments on, 453, 454
- Flying Boat, Domier Napier, Captain Courtney's, 43, 44
- Folded Logarithmic Horn, "Scientific," 140
- Folded Loops, Method of Coil Winding Composed of, 67
- Forno Two-stage L.F. Coupler, 345
- "Four Point" Condenser, Newey, 10
- France, Wireless Ever in, 701
- Frequency and Wavelength Abac, 39
- Fultograph, Portrait of H.H. the King, 642
- "Fultograph" The, 555, 556, 557, 558, 559, 633
- Transmitter, 642
- Fuse Holder, "Bulgin" Safety, 836
- G.9 "Popular" Grid Bias Battery, Siemens, 208
- Gambrell "Table Model Two" Mains Receiver, 345
- Gambrell Twin Fuse Holder and Fuse Unit, 345
- Unit, 236
- "Volvurnia," 853
- G.E.C. H.T. Battery Eliminator, 236
- 3-valve Receiver, 346
- Geophone "Victor 3" (Ballot Result), 706, 707
- 66LL, Transmitting Apparatus of Mr. J. W. Mathews, 650
- Golders Green and Hendon Radio Society, 109, 110
- "Gold Wave" Aerial Wire, 688
- Goodman's Double Acting Reed Unit, 262
- Gramophone Pick-up, 346
- Graham-Farish Grid Leak Base, 112
- Gramophone Amplifier, A.C., 755, 756, 757, 758, 759
- Pick-up, Burndept, 234
- Pick-up to "Kilo-Mag Four," Adding a (Diagram), 692
- Pick-up to the "Megavox" Receiver, How to Connect a (Diagram), 622
- Graves "Vulcan" Two (Broadcast Receivers), 776
- G.R.C. Absorption Wavemeter, 537, 538
- Grid Leak Base, Graham-Farish, 112
- Grid Swing with a Pentode, Permissible (Curves), 584, 585, 586
- G6WN, Owned and Operated by Mr. H. V. Wilkins, 572
- Hambury Station, 833
- Hartie Model 9-wave Selector, 744
- Slow-motion Dial, etc., 563
- Hartley Circuits, Switched (Diagrams), 750
- (Oscillator, A Single Coil (Diagram), 749
- H.F. Amplifier Design: Further Notes on (Diagrams), 259, 290, 291
- Amplifier, The (Curves), 243, 244, 245
- Choke, A.B. Products, 774
- Choke, Irganic, 836
- Choke, New Lewcos, 537
- Choke, "Tayloradio," 852
- Chokes, 372, 373, 374, 375
- Currents in the Phone Leads (Diagram), 489
- Transformer for S.G. Valves (Diagram), 808
- Transformer for Screened Grid Valves, 867
- Transformers, Building, 455, 456, 457
- Unit for "R.C. Threesome," Ediswan Type C, 139
- High-frequency Resistance, 810, et seq., 845, et seq.
- Hindenburg, President (Pictures from Berlin), 727
- Hounslow Calling, 21
- H.T. Batteries, Dry Cell, 815, et seq.
- Batteries, Longer Life for (Diagram), 686
- Battery with Resistance Stage Incorporated, 754
- Eliminator, Choosing an, 450, 451, 452
- Supply, A Safe (Diagram), 768
- Unit, Oldham 10-volt, 20
- Units, Tudor, 564
- Hungary, The Voice of, 446
- "Ideal" Condenser, Polar, 205
- Irganic Dual-impedance Capacity Unit, 347
- Dual-impedance Coupling Unit, 775
- H.F. Choke, 836
- H.T. Eliminator and L.T. Trickle Charger, 235
- Impedance of a Moving Coil Loud Speaker, The (Curves), 729, 730, 731
- "Imperial" Volume Control, 174
- Independent Volume Control for Several Loud Speakers (Diagram), 180
- Inductance, Capacity and Frequency (Useful Data Charts), 83, 111, 126
- Intervalve Transformer, Brown Type "A," 640
- Japan, Gala Day in, 269
- Japan, In Modern (Osaka Broadcasting Station), 231
- Jennens Components, 510
- Kalundborg, 661
- "Kilo-Mag Four," Adding a Gramophone Pick-up to the (Diagram), 692
- Kilo-Mag Four, The, 550, 551, 552, 553, 554, 588, 589, 590, 591
- Langham Portable Set, 347
- Lauder, Sir Harry, 712
- Lewcos H.F. Choke, New, 537
- Short-wave Unit, 347
- L.F. Amplifier, Scientific Design of the, 169, 190, 191, 192
- Amplifier, The, 164, 165, 166
- Stage, Switching Out An (Diagram), 849
- "Liberty" Super-het., New, 20
- Lightning Arrester, Philips, 71
- Light-sensitive Pick-up, A, 598
- Linz Relay Station, 531, 532
- "Lion" Loud Speaker, Amplion (Ballot Result), 703, 704, 705
- Lissen Variable Condensers, 538
- Lissen Wire-wound Anode Resistances, 173
- Loewe Frame Aerial Receiver, 307
- Loose-coupling (Diagram), 10
- Loss of Energy due to Dielectric, Diagrams (High-frequency Resistance), 845, 846, 847, 848
- Loriadapter, The, 112

- Lotus Log Mid-line Condenser, 348
 — Miniature Valve-holder, 538
 — Transportable Receiver, Self-contained, 348
 Loud Speaker Designed for Piston Action, 754
 Loud Speakers on the Railway, 178
 L.S.A. Leclanché Cell, Size No. 8100, 262
- Maadi, near Cairo, 391
 Magnet System of the Burndept Pick-up, 234
 Magnum Fixed Condenser, 234
 Magnum "Vibro" Valve-holder, 261
 Mains Equipment, Types of, 235, 236, 237, 238
 — Transformer Design, 569, 570, 571, 630, 631, 632
 — Users. Safety First for (Diagrams), 220
 Mamepe, Mr. O., 364
 Manchester Headquarters of B.B.C. ("Broadcasting House"), 118
 — Radio Exhibition Plans, 540, 578, 579
 — Radio Show, Exhibits at, pp. 605 to 620
 — Wireless Pictures at (Mrs. Philip Snowden), 587
- Marconi All-power Unit for D.C. Mains, 236
 — and Osram Power Valves; Curves (Valves We Have Tested), 684, 685
 Marconiphone Model Portable (Ballot Result), 705, 706
 — "Popular" L.F. Transformer, 852
 — R.K. Moving-coil Loud Speaker, 293
 — Self-contained Receiver, 348
 — Short-wave Set (Broadcast Receivers), 593, 594, 595
 — Variable Condenser, 174
 Marconi's Yacht, Senatore, 11, 12
 Mathews, G6LL, Transmitting Apparatus of Mr. J. W., 650
 Mathieu, Mr. G. A. (Music by Beam), 23
 McMichael Binocular Choke, 687
 — "Screened Dimic Three," 348
 Megavox Eliminator, 787, et seq., 827, et seq.
 "Megavox" Receiver, How to Connect a Gramophone Pick-up to the (Diagram), 62
 — The, 331, et seq.
 — Three," Aconicab Pedestal Cabinet for, 775
 — Three," Further Notes on the, 385, 386, 458, 459, 460
 "Megavox," Wearite Coils for the, 640
 Megger, Improved (Diagram), 120
 Metal Rectifiers, 223, 224, 225, 226
 — Rectifier, The Theory of the (Diagrams), 824, 825, 826
 Metro-Vick Power Unit, 235
 Met-Vick Combined Eliminator, Model "B" (Ballot Result), 708, 709
 — Elastic Aerial Unit, 349
 Milan Broadcasting Station, 503
 Miniature Condensers, Peto-Scott, 174
 — Valve-holder, Lotus, 538
 Minimum H.F. Resistance, Diameter of Wire or Strand to give Coil (Useful Data Charts), 834, 835
 Monotone Power Valve, Type D.6P., 261
 Moscow, The Invisible Band at, 574
 Motor Boat, A Telearchic, 472
 Moving-coil Loud Speakers, Resonance in, 497, et seq., 539, et seq.
 — coil Loud Speakers, The Impedance of a (Curves), 729, 730, 731
 — coil Modifications, 122, 123
 — coil, The Output Stage and the, 154, et seq.
 — coil with 2,500 Turns, Winding a, 354
 Mullard High Magnification Factor Pentode Output Valve, 349
 — Pentode Valve, P.M.24 (Ballot Result), 709, 710
 — P.M.4D. (Valves We Have Tested), 96
 — P.M.12 (Valves We Have Tested), 25
 Multilayer Coils, Self-inductance of (Useful Data Charts), 789, et seq.
 Multiple Battery Lead, A Tidy, 33
- Neutralising Condenser, Bulgin Baseboard, 41
 New "All-wave Four," Notes on the, 13, 14
 — "Empire" Receiver, The, 854, et seq.
 — New Lamps for Old" (Diagrams), 495, 496
 Newey "Four-point" Condenser, 19
 News Pictures, Picture Broadcasting and, 377, et seq.
 — "Noctovision" Television Apparatus, 598
 North Middlesex Radio Society, 106
 N.S.F. Products, 563
- "O.B." Van, The, 55
 Odham 10-volt H.T. Unit, 20
 Olympia, A Forecast of (Guide to the Show), 339, et seq.
 — Exhibition, Exhibits at, 399, et seq.
 — Exhibition, Plan of, 357, 398
 — Exhibition, Poster Competition, 226
 — Further Gleanings from, 473, et seq.
 Ormond Cabinet Loud Speaker, 71
 Osaka Broadcasting Station (In Modern Japan), 231
 Oscillator Unit (Diagram), 58
 Osram Power Valves, Marconi and (Valves We Have Tested), 684, 685
 Oszilloplan Loud Speaker, 309
 Output Stage and the Moving Coil, The, 154, 155, 156, 157
- Output Stage and the Pentode, The (Curves), 30, et seq., 77, 80, 113, 114, 115
- Parachute, Talks from a, 543
 Parallel Feed (Diagram), 370
 Paris Show, Review of the (Salon de T.S.F.), 643, et seq.
 Pedestal Cabinet for "Megavox Three," Aconicab, 775
 Peerless Shockproof Valve Holder, 205
 Pentode, Permissible Grid Swing with a (Curves), 584, et seq.
 — Quality Three, The, 115
 — Screened Grid and the (A New Receiver), 302, 303, 304, 305
 — The (Curves), 7, 8
 — The Output Stage and the (Curves), 30, 31, 32, 33, 77, 80, 113, 114, 115
 — Two, 524, et seq.
 — Valve, P.M.24, Mullard, Ballot Result, 709, 710
- Peto-Scott Miniature Condensers, 174
 Phillips Lightning Arrester, 71
 Phone Leads, H.F. Current in the (Diagram), 489
 Pick-up Carrier, Watmel, 775
 Picture Broadcasting and News Pictures, 377, et seq.
 — Broadcasting Begins ("Fotograph" Transmitter Apparatus), 642
 — Receiver, An Hour with a, 752, 753
 — Reception at Savoy Hill, 633, 642
 Pictures from Berlin (President Hindenburg), 727
 Piezo Crystal Holder, 754
 "Pitcairn Calling," 318
 P.M.4D, Mullard (Valves We Have Tested), 96
 P.M.12, Mullard (Valves We Have Tested), 25
 Polar "Ideal" Condenser, 205
 Police Picture Transmitting Apparatus at Berlin Show, 309
 — "Popular" L.F. Transformer, Marconiphone, 852
 Portable Transmitters, 501, 502
 "Tortette" Single-Valve Set by E. J. Lever & Co., 352
 Poster Competition, Olympia Exhibition, 226
 Postlethwaite Coils, 774
 Potential Regulating Apparatus, A Group of Modern, 238
 Power Unit by Metro-Vick Supplies, Ltd., 235
 Progress, The Trend of, 461, et seq.
 Pulsynetic Clock (Time-keeping by Wireless), 70
 Pye Anti-Capacity Valve Holder, 41
 Pye Transformer for L.T. Charges using Metal Rectifiers, 350
- Radielle Eliminator for A.C. Mains, 237
 Radio Frequencies, Reactance of a Coil at (Useful Data Charts), 204
 — Frequencies, Reactance of a Condenser at (Useful Data Charts), 294, 295
 — Gits for Christmas, 780, 781, 782
 Railway, Loud Speakers on the, 178
 "R.C. Threesome," Ediswan Type C H.F. Unit for, 139
 Reactance of a Coil at Audio Frequencies, The (Useful Data Charts), 159
 — of a Coil at Radio Frequencies, The (Useful Data Charts), 204
 — of a Condenser at Audio Frequencies, The (Useful Data Charts), 252, 253
 — of a Condenser at Radio Frequencies, The (Useful Data Charts), 294, 295
 Reaction Circuit, Simple (Diagram), 807
 — Its Uses and Abuses (Diagrams), 517, 518
 Reading Circuit Diagrams (Diagram), 246
 Readshaw's Station, Mr. T. W., 504
 "Realistic" Loud Speaker, 687
 Receiver Design, Compromise in, 91, 127, 163, 189, 243, 289
 Red Diamond Switch, 234
 Regentone de Luxe H.T. Eliminator, 236
 Resistance, High Frequency, 810, et seq., 845, et seq.
 Resistance in Parallel, The Value of (Useful Data Charts), 483, 484
 Resistance Wire, The D.C. Resistance of (Useful Data Charts), 388, 389
 Resonance in Moving-Coil Loud Speakers, 497, et seq., 538, et seq.
 Ripault Double-Capacity H.T. Battery, 640
 — Lateral-Action Condenser, 262
 R.I. and Varley Adjustable Choke, 238
 — and Varley Two-Range Tuner, 837
 — Varley "Anti Mobo" Unit, 261
 R.K. Moving-Coil Loud Speaker, Marconiphone, 293
 R.S.G.B., Amateur Transmitters in Conference, 562
 R.S.V.P. Gramophone Five-Valve Receiver, 351
- Safe H.T. Supply, A (Diagram), 768
 Safety First for Mains Users (Diagrams), 220
 Salon de T.S.F.—Review of Paris Show, 643, et seq.
- San Sebastian Broadcasting Station, 515
 Savage Type C 30/2 Smoothing Choke, 744
 Science Museum, At the, 49, et seq.
 "Scientific" Folded Logarithmic Horn, 140
 Scott "All-Wave" Tuner, 510
- Scottish Amateur Station 6GVU, A, 504
 Screened Dimic Three, The (Broadcast Receivers), 175, 176
 — Grid and Pentode Three (A New Receiver), 302, et seq.
 — Grid Valve as a Detector (Curves), 492, et seq.
 — Valves, Bias for (Diagram), 651
 Screwdriver, Expanding, 205
 Selector Five-Valve Attaché Case Portable Set, 351
 — Switch for Bank of Condensers, Special, 840
 Self-Inductance of Multilayer Coils (Useful Data Charts), 769, et seq.
 — Inductance of Solenoids (Useful Data Charts), 717, et seq.
 Sets of the Season, 654, et seq.
 S.G.220, Cosmor (Valves We Have Tested), 767
 S.G. Valves, H.F. Transformer for (Diagram), 808
 Shockproof Valve Holder, Peerless, 205
 Short-Wave Detector with Differential Reaction, 720
 Siemens G9 "Popular" Grid Bias Battery, 293
 — Halske Loud Speaker Car (Music on Tour), 287
 — No. 1075 H.T. Battery, 351
 — No. 6087Y Battery, 140
 Signal Measurement (Diagram), 40
 — Unit, A Territorial, 575
 Simplified Circuits (How to Dissect a Theoretical Diagram), 741, 742
 Single-Coil Hartley Oscillator (Diagram), 749
 Six-Pin Base, Colvern, 325
 — Sixty New Type Screened Grid Valve, 351
 Slow Motion Dial, etc., Harlie, 563
 Smith's Cabinets, 837
 Snowden, Mrs. Philip (Wireless Pictures at Manchester), 587
 "Soldoneta" Pocket Soldering Outfit, 688
 Solenoids, Self-Inductance of (Useful Data Charts), 717, 718, 719
 Southend and District Radio Society (A Transmitter-Receiver), 133
 Space, Echoes from the Depths of, 722, 723
 Spade Terminals Made from Tinned Copper Wire, 251
 S.P.16 Series of Two-Volt Met-Vick Valves (Valves We Have Tested), 529, 530
 S.R.S. Short-Wave Adaptor, 173
 Stal Two-Volt Power Valve, 325
 Standard Four, Testing a, 103, 104
 "Standard" Leclanché L.T. Battery, 853
 Standard Wet Battery Company's New Three-Range Meter, 352
 "Stella" Eliminator Cabinet, 140
 Super-Sensitive Receivers (Diagrams), 161, 162
 — "Supra" Type of Sure-a-Lite Battery, 72
 Switched Bartley Circuits (Diagrams), 750
 Switching Out an L.F. Stage (Diagram), 849
 — Waveband (Diagrams), 625, 626, 627, 628
 "Switch-over Three," 2, et seq., 34, et seq.
 "Synchronism" Twin Condensers, Cydon, 743, 744
- Talking Films, 792, 793, 794, 842, 843, 844
 "Tayloradio" H.F. Choke, 852
 Telearchic Motor Boat, A, 472
 Television Apparatus, "Noctovision," 508
 Territorial Field Set, A, 796
 — Signal Unit, A, 575
 Testing a Standard Four, 103, 104
 Theoretical Diagram, How to Dissect a (Simplified Circuits), 741, 742
 Theory of the Metal Rectifier, The (Diagrams), 824, 825, 826
 Three-in-One Receiver by Mr. H. K. Bourne, 134
 Three-Valve Portable, The Advance (Broadcast Receivers), 68
 Throttle-Controlled Circuit for "Everyman Portable" (Diagram), 778
 Time Constant of Grid Leak and Condenser (Useful Data Charts), 680, 681
 — Keeping by Wireless (Pulsynetic Clock), 70
 Transatlantic Flight Wireless, 43, 44
 — Success at 10 Metres, 201, 202
 Transformer Construction, Modified, 490
 — Design, Mains, 569, 570, 571, 630, 631, 632
 Transmitter-Receiver, A (Southend and District Radio Society), 133
 Transmitters in Conference, Amateur, 562
 — Portable, 501, 502
 Trickle Charger, The "Brayton," 688
 — Chargers, Three Popular, 237
 Triple-Range Voltmeters, Ferranti, 139
 Trix Fixed Condenser, 173
 — H.F. Choke, 743
 — "Three-Base," 41
 T.S.F., Salon de (Review of Paris Show), 643, et seq.
 Tudor H.T. Units, 564
 Tuner Units, Davex, 564
 Tunometer Automatic Tuner, Parts of the, 20
 — Two-Range Four," 311, et seq.
 — Range Tuner, R.I. and Varley, 837
- Unspillable Accumulator, Edwards', 72

Useful Data Charts, 38, 39, 83, 111, 158, 204, 252, 295, 361, 368, 389, 483, 484, 500, 580, 581, 576, 597, 648, 649, 680, 717, 718, 719, 769, 770, 771, 834, 835, 864

Valve Characteristic Models, 49, 50, 51

— Rectifiers, Well-known, 337

Variable Condenser, Marconiphone, 174

— Condensers, Lissen, 538

"Vibro" Valve Holder, Magnum, 261

"Victor 3," Geophone, 706, 707

Volts, Draining (Diagrams), 724, 725, 726

— Ohms and Amperes, The Relation Between

(Useful Data Charts), 580, 581

Volume Control (Diagram), 582

— Control for Several Loud Speakers, In-

dependent (Diagrams), 180

— Control, "Imperial," 174

Volume Controls and Overloading (Diagram), 384

"Voluvernina," Gambrell, 853

"Vulcan" Two, Graves (Broadcast Receivers),

776

Wander Plug, Burndept, 112

Wasmel Pick-up Carrier, 775

Watts, Amperes and Volts, The Relation Be-

tween (Useful Data Charts), 596, 597

Waveband Switching (Diagrams), 625, et seq.

Wavemeter Mysteries Explained, 255

— The Simplest (Diagram), 194

Wavetrap, Absorption, Connections of (Dia-

gram), 868

Wearite Anti-Capacity Switches, 688

— Coils for the Megavox, 640

Wearite H.F. Amplifying Unit, 352

— Wire-Wound Fixed Condensers and Holders,

325

Westinghouse Grid Bias Rectifier Unit, 352

Weston Accumulator Carrier, 564

— Radio Tester, 42

Wilkins, Mr. H. V., Set, G6WN, 672

Winding a Moving Coil with 2,500 Turns, 354

Wired Wireless, Broadcasting by (Diagrams,

etc.), 677, 678, 679, 698, 699, 700

Wireless in the Wilderness (Mr. Wally Wilson),

740

— Pictures at Manchester (Mrs. Philip Snow-

den), 587

— Telephony in the Far South, 145, et seq.

Wire-Wound Anode Resistances, Lissen, 173

W.T.10 H.T. Accumulator, Exide (Ballot Re-

sult), 707, 708

AUTHORS

Auschitzky, Pierre, 201

Beatty, R. T., M.A., B.E., S.Sc., 38, 722, 728

Bell, D'Orsay, M.A., 477

Branch, L. E. T., B.Sc., 122

Castellain, A. P., B.Sc., A.C.G.I., D.I.C., 492

Colebrook, F. M., B.Sc., D.I.C., 65

Crawley, Lieut.-Colonel Chetwode, M.I.E.E., 801

Denman, R. P. G., M.A., A.M.I.E.E., 49

Dent, H. B., 221, 495, 569, 630

Deveraux, F. L., B.Sc., 372

Eckersley, P. P., 370

"Empiricist," 752

Garland, H. J., 145

Gilmour, Hugh W., 279

Hatcher, E. L., and R. L. Spith-Rose, D.Sc.,

A.M.I.E.E., 501

Haynes, F. H., 223, 311, 353, 377, 555, 694, 737

Jackson, W., M.Sc., 141

McLachlan, N. W., D.Sc., M.I.E.E., F.Inst.P.,

30, 77, 113, 154, 302, 385, 458, 497, 539, 584,

729

— N. W., D.Sc., M.I.E.E., F.Inst.P., and

W. I. G. Page, B.Sc., 331

Minter, N. P. Vincer, 13, 214, 274, 517, 755

Page, W. I. G., B.Sc., 7, 381, 524, 724, 787, 827

— W. I. G., B.Sc., and N. W. McLachlan,

D.Sc., M.I.E.E., F.Inst.P., 331

"Radiophare," 10, 40, 81, 125, 161, 194, 220, 246,

577, 741

Rose, R. L. Smith, D.Sc., Ph.D., A.M.I.E.E., 186,

247

— R. L. Smith, D.Sc., A.M.I.E.E., and E. L.

Hatcher, 501

Sanderson, R. W. W., M.Sc., 815

Smith, H. F., 2, 34, 455, 550, 588, 625, 769, 783,

854

— Rose, R. L., D.Sc., Ph.D., A.M.I.E.E., 186,

247

— Rose, R. L., D.Sc., A.M.I.E.E., and E. L.

Hatcher, 501

Sowerby, A. L. M., M.Sc., 60, 97, 450, 457, 685,

760, 791, 810, 845

Vincer-Minter, N. P., 13, 214, 274, 517, 755

BOOK REVIEWS.

"Patent Law and Practice," by A. W. Griffiths,

B.Sc., 387

"Wireless Diary for 1929," 629

— "Trader Year Book and Diary, 1929," 819

The Wireless World

AND
RADIO REVIEW
(16th Year of Publication)

No. 462.

WEDNESDAY, JULY 4TH, 1928.

VOL. XXIII, No. 1.

Editor: HUGH S. POCOCK.

Assistant Editor: F. H. HAYNES.

Editorial Offices: 116-117, FLEET STREET, LONDON, E.C. 4.

Editorial Telephone: City 9472 (5 lines).

Advertising and Publishing Offices:

DORSET HOUSE, TUDOR STREET, LONDON, E.C. 4.

Telephone City 2847 (13 lines) Telegrams: "Ethaworld, Fleet, London."

COVENTRY Hertford Street

Telegrams "Cyclist, Coventry." Telephone 5210 Coventry.

BIRMINGHAM: Guildhall Buildings, Navigation Street

Telegrams "Autopress, Birmingham." Telephones 2970 and 2971 Midlan 1.

MANCHESTER 260, Deansgate.

Telegrams "Hille, Manchester." Telephone 8970 City (4 lines).

Subscription Rates: Home, 17s. 4d.; Canada, 17s. 4d.;
other countries abroad, 19s. 6d. per annum.

As many of the circuits and apparatus described in these pages are covered by patents, readers are advised, before making use of them, to satisfy themselves that they would not be infringing patents.

CONTENTS OF THIS ISSUE.

	PAGE
EDITORIAL	1
SWITCH-OVER THREE. BY H. F. SMITH	2
THE PENTODE. BY W. I. G. PAGE	7
LOOSE-COUPLING. BY RADIOPHARE	10
CURRENT TOPICS	11
NOTES ON THE NEW ALL-WAVE FOUR	13
PROGRAMMES FROM ABROAD	15
NEW APPARATUS	19
NEWS FROM THE CLUBS	21
RECENT INVENTIONS	22
BROADCAST BREVETTES	23
VALVES WE HAVE TESTED. THE MULLARD P.M.12	25
LETTERS TO THE EDITOR	26
READERS' PROBLEMS	27

PROGRAMMES FROM ABROAD.

COMMENCING with the present issue of *The Wireless World*, readers will find that a new feature has been introduced in the form of the publication of a selection of the week-end programmes of the principal stations abroad which can regularly be heard in this country.

The interest in foreign reception has been steadily increasing, and there are to-day many thousands of receivers in existence which are capable of reproducing the foreign programmes sufficiently well to provide an attraction even for those whose interest may be almost non-technical, and who listen solely for the sake of the programmes. We do not consider that we should be justified in devoting sufficient space to include the programmes for the week, but we feel that it is at the week-end that most listeners can devote time to distant reception, and it is also the occasion when perhaps there is a greater demand for alternatives to the programmes supplied by the B.B.C.

By a special arrangement which we have entered into, we shall be able to publish these programmes

week by week, and the latest details up to the time of going to press will be included.

o o o o

BROADCASTING AND EDUCATION.

SO long as the B.B.C. remained a company under the direction of Sir John Reith, the public had the satisfaction of feeling that Sir John exercised, to all practical purposes, an autocratic control over the destinies of the organisation, and was the responsible head on which to shower praise or criticism according to whether listeners approved or disapproved of the type of programmes broadcast. Since the formation of the Corporation, however, the control of the B.B.C. has passed to a Board of Governors which constitute in the mind of the public an impersonal control, which, by virtue of numbers, or perhaps because it is a Government appointed Board, seems to be uninfluenced by considerations of satisfying the tastes of the public.

We cannot help feeling that the idea of utilising broadcasting as a means of education is tending to become an obsession in the minds of the Board of Governors. We should be the last to suggest that education should be neglected in the compilation of the programmes; but, on the other hand, if the present enthusiasm of the Board to uplift and educate the listener is not checked we foresee the definite possibility that the whole aim of broadcasting may be defeated, in that listeners, because they are not entertained and because the introduction of educational matter is pursued at too great a speed to be assimilated, may lose the habit of listening. It would then become a very difficult task indeed to re-create the habit when it was found that the interest in broadcasting was on the wane. We venture to think that Sir John Reith himself realises the mistake which is now being made, but no longer having the autocratic powers which once were his, it is a difficult matter for him now to stem the tide.

At a conference arranged recently between the B.B.C. and the British Institute of Adult Education, Sir John Reith said that "the primary responsibility of the B.B.C. was to entertain their *clientèle*. Whatever they did, therefore, with respect to education, must be subject to that claim." Here, then, is what in our opinion forms the basis of a sound policy on which the B.B.C. should build, and what causes us anxiety is that the present Board of Governors seem far more impatient in the direction of utilising broadcasting for education than meets with public approval or conforms to the policy of Sir John, who prior to the appointment of a Board of Governors so ably conducted the affairs of the broadcasting organisation.

SWITCH-OVER THREE

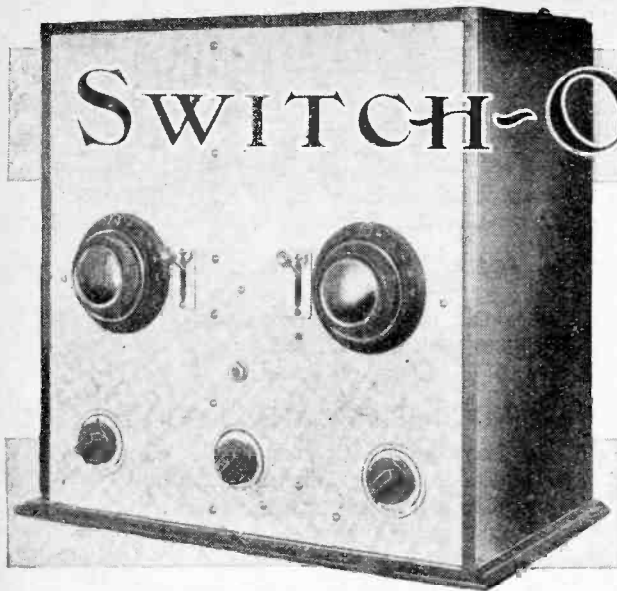

An Efficient Switching Scheme,
giving Continuous Tuning from
250 to 2,200 Metres.

By H. F. SMITH.

THE operation of changing coils for different wavebands, which seemed primitive enough—as compared with standard electrical practice—before receivers were completely enclosed, has become still more irksome since the so-called American cabinet has been generally adopted. This is partly because access to the sockets in a modern set involves delving into its vitals, and also because coil mountings are more complicated than hitherto, due to the fact that from three to seven contacts often replace the two connections of the simple plug-in inductance. Moreover, intervalve

couplings nowadays are generally more fragile, thus requiring careful handling.

The development of a switching scheme to cover numerous wavebands without introducing serious losses is undoubtedly a difficult problem, but the writer feels that we have over-estimated the obstacles in the way of producing an efficient method of quickly and easily switching coils for the two broadcast wavebands to which most amateurs normally confine their attentions. Be this as it may, it was found possible to develop the straightforward receiver to be described in this article without having resort to any artifice other than fairly thorough screening.

“How much signal strength must I sacrifice for the undoubted convenience of switching?” will be the first

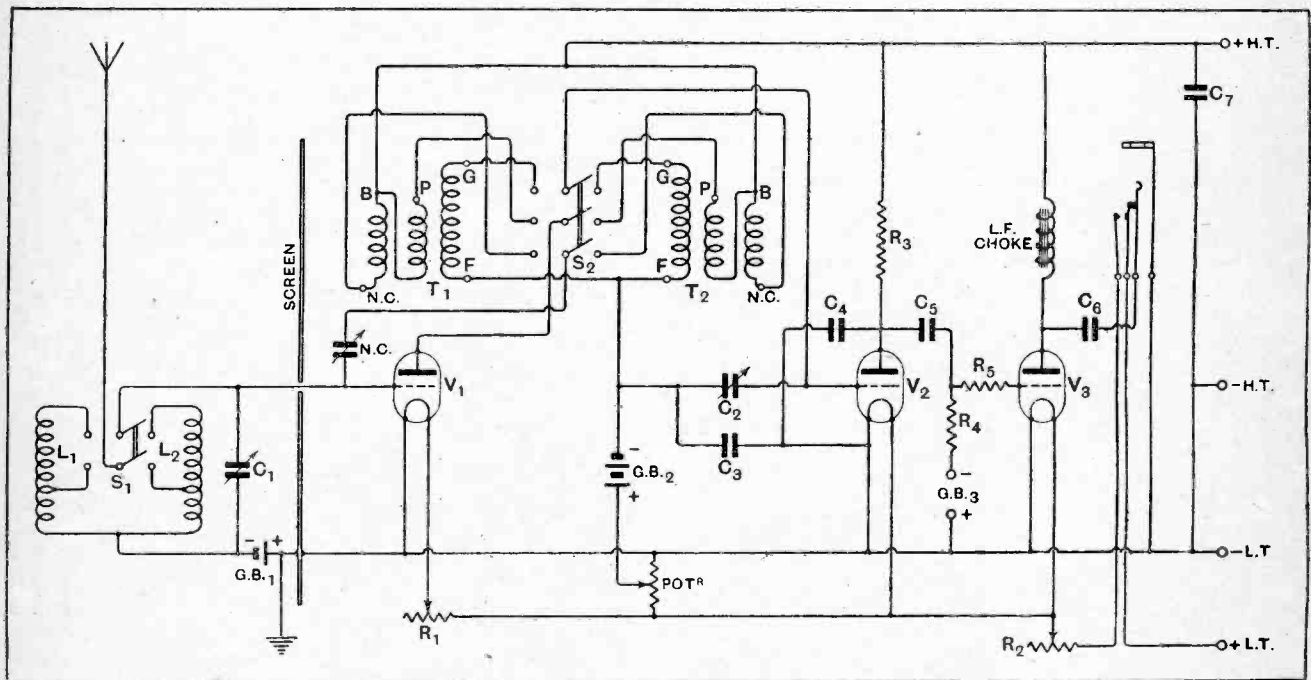

Fig. 1.—The circuit diagram. C_1, C_2 , 0.0005 mfd.; C_3 , 0.25 mfd.; C_4 , semi-variable, 0.0003 mfd.; C_5 , 0.005 mfd.; C_6, C_7 , 2 mfd.; R_1 , volume control rheostat, 50 ohms; R_2 , master rheostat, 6 ohms; R_3 , anode resistance, 250,000 ohms; R_4 , grid leak, 2 megohms; R_5 , H.F. stopping resistance, 0.25 megohm.

Switch-Over Three.—

question of the enthusiast whose watchword is efficiency. This matter has been the subject of careful measurements made under practical conditions, and in such a way as to give the fairest basis of comparison with the best type of fixed-waveband receiver having one H.F. stage and an anode bend rectifier, which was chosen as a standard. In terms of H.F. voltage developed across the detector grid circuit for a steady input from a fixed-coupled aerial, the switch-over set shows a loss of about 10 per cent. To the uninitiated this may seem to be appreciable, but, judged from the point of view of audibility, it is quite negligible, and in any case it is offset by slightly unbalancing the H.F. circuit. In fact, the difference between the two receivers was so slight that it was necessary to take a number of readings and to strike an average.

Ignoring the switching connections, the circuit, which is shown in Fig. 1, is the conventional combination of H.F. amplifier, anode bend detector, and a resistance-coupled output valve; an arrangement which has many advantages, being selective enough for all but the most exacting requirements in a "wipe-out" area, and sufficiently sensitive to give loud speaker signals up to the capacity of a super-power valve at distances of from 40 to 50 miles from a main station, 70 miles from 5GB, and 150 miles from 5XX. Average receiving conditions are assumed. The set should not be looked upon as intended for long-distance reception, although after dark many Continental transmissions are received. It is particularly suited for use with a simple eliminator having a single voltage output; there is no possibility of "motor-boating" or low-frequency reaction with a circuit of this kind.

A Straightforward Waveband Change.

When a metal panel is used in conjunction with a circuit embodying a choke-capacity output, a jack offers a convenient point of connection for the loud speaker. It is adopted in this case, the jack being arranged to close the low-tension circuit when its plug is inserted. Strictly speaking, this renders unnecessary the master rheostat R_2 , but as an additional filament control is sometimes useful, and as there is ample panel space for

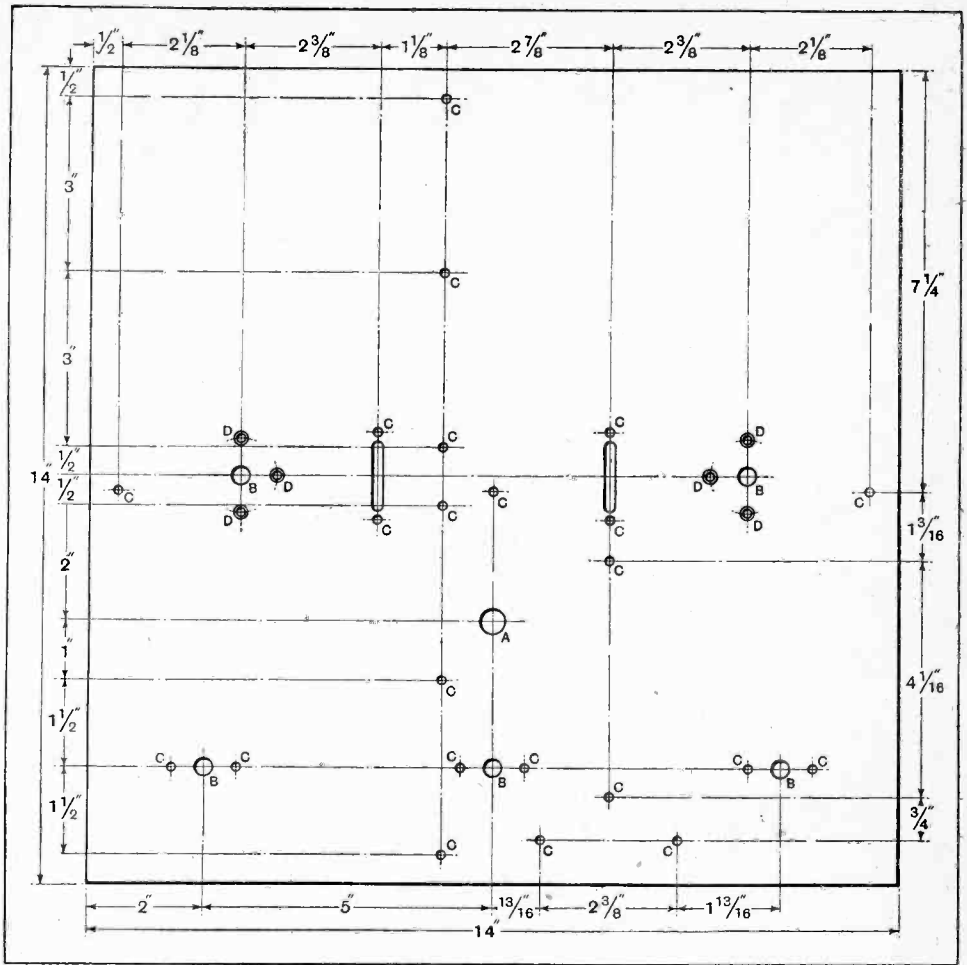

Fig. 2.—Drilling details of the front panel. A, 7/16in.; B, 5/16in.; C, 5/32in.; D, 5/32in., countersunk for No. 4 B.A. screws. Holes for securing the panel to its cabinet are not shown.

its accommodation, it was therefore retained in this case.

For those who require long-range reception it will be necessary to add another L.F. stage; no difficulty will be experienced in making this addition provided the width of the panel is increased by about 3in. A slight improvement in range is obtained by replacing the present resistance by a transformer; although this form of coupling after an anode bend detector may in the ordinary way lead to difficulties, one feels that it has been rather neglected, and in any case there are no serious pitfalls if the new Mullard P.M.4D rectifying valve is used.

Although the addition of switches tends to complicate the circuit diagram, a few moments' consideration of Fig. 1 will show how the connections of the various coils are changed. One pole of the switch S_1 joins the aerial to a tapping point on the appropriate input grid coil, while the second changes the grid lead of the H.F. valve V_1 . The three blades of switch S_2 are connected to detector grid, H.F. plate, and neutralising condenser, the corresponding sets of contacts being joined to the windings of long- and short-wave H.F. transformers T_1 and T_2 . The low-potential ends of the various coils are connected together and to either grid bias or H.T. bat-

Switch-Over Three.—

teries. Thus only the coils are duplicated, and a multiplicity of switch contacts is avoided.

It will be seen from the illustrations that the metal "chassis" on which the apparatus is assembled is divided into four separate compartments, the lower two accommodating the long-wave coils, with the short-wave transformers above them. The tuning condensers and switches, which are common to the apparatus associated with each waveband, are mounted on the centre line

drilled to the dimensions given in Fig. 2. The horizontal platform, of the same material, has a flange by means of which it is secured to the panel; it must be cut away to clear both variable condensers and switches in the manner indicated in Fig. 3 (A). Two vertical screens, of the size shown in Fig. 3 (C) are also required, the upper one being drilled for mounting by-pass condensers C_3 , C_7 , and also with a $\frac{1}{4}$ in. clearance hole to pass a wire joined to the grid of V_1 . The lower vertical screen is plain, except for a hole to clear a wire

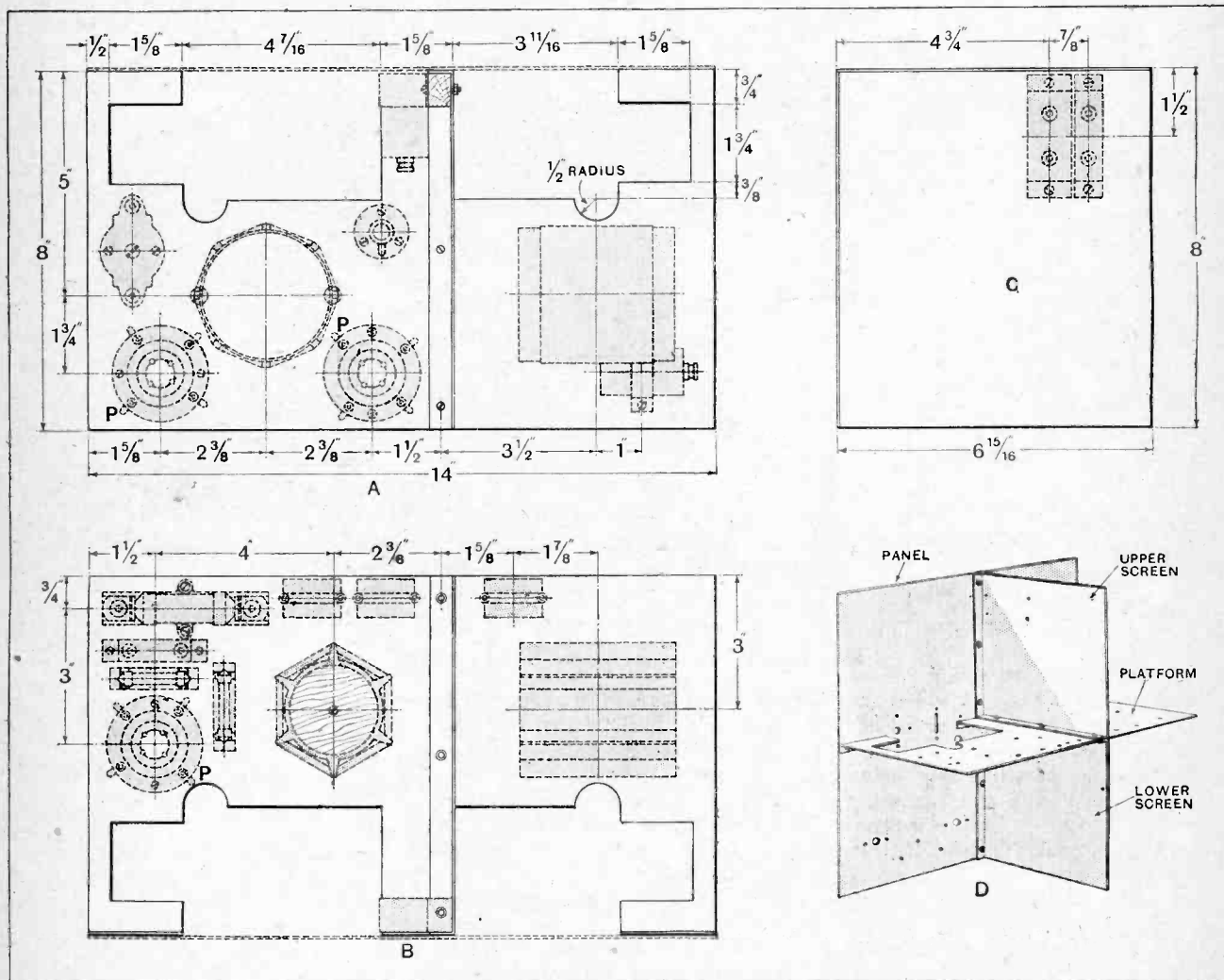

Fig. 3.—(A) Layout of components on upper surface of the platform, showing dimensions of cut-outs to accommodate variable condensers and switches. (B) Mounting of components on the underside of platform. (C) The upper screen, showing mounting of by-pass condensers; the lower screen is of similar dimensions. (D) Sketch showing assembly of the metal "chassis."

dividing the two sections in such a way that they are symmetrically disposed with relation to the coil terminals, so that the wiring is reasonably short and direct. It will be obvious that *both* switches must be operated to change from one waveband to the other; it really seems unnecessary to link them together mechanically, but this refinement can easily be added by the constructor if he so desires.

The front panel is of $\frac{1}{16}$ in. aluminium sheet, cut and

connected to rheostat R_1 . From the perspective sketch, Fig. 3 (D), the assembly of these various parts will be made clear.

In Fig. 3 (A) the mounting and positions of the various components on the upper surfaces are shown. The Ever-ready "O" cells, used as $G.B._1$ and $G.B._2$, are secured by light metal strips, the latter being wedged in position by a small block of wood. The valve holders and neutralising condenser are raised, respectively, $\frac{3}{8}$ in.

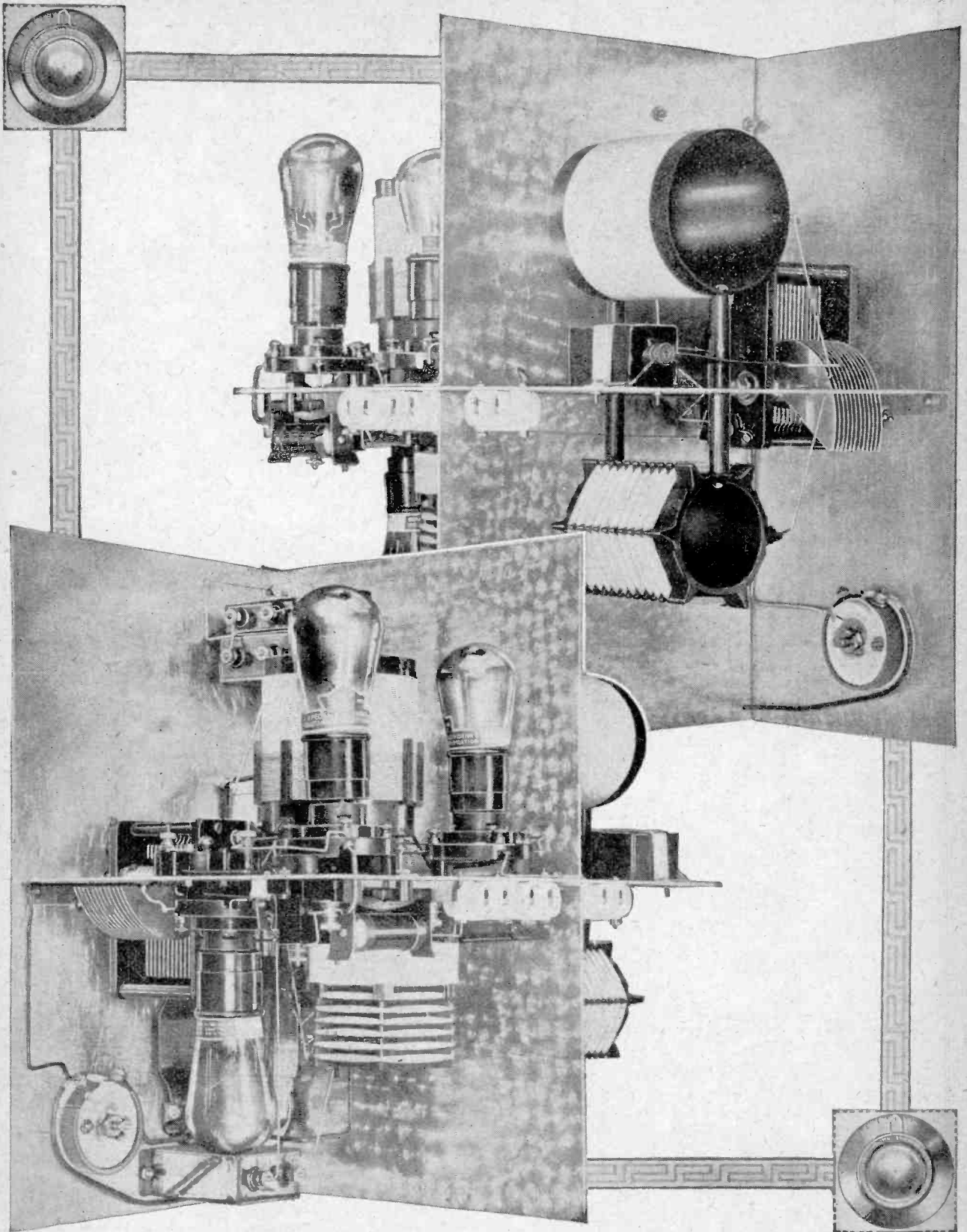

LIST OF PARTS.

- | | |
|---|--|
| <ul style="list-style-type: none"> 2 Variable condensers, log scale, 0.0005 mfd. (Burndept). 2 Condensers, 2 mfd. (T.C.C.). 1 Condenser, 0.25 mfd. (T.C.C.). 1 Condenser, "Presel," 0.0003 mfd. (Igranic). 1 Condenser, 0.005 mfd., Type 620 (Dubilier). 1 Neutralising condenser (Gambrell). 1 L.F. choke, 30 henries (Sterling). 1 Switch, 2-pole change-over (Utility). 1 Switch, 3-pole change-over (Utility). 1 Rheostat, 50 ohms (Igranic-Pacent). 1 Rheostat, 6 ohms (Igranic-Pacent). 1 Potentiometer (Igranic-Pacent). 3 Valve holders (Wearite). | <ul style="list-style-type: none"> 1 Jack, single circuit open filament control (Edison Bell). 3 Two-way porcelain connectors (Athol). 1 Anode resistance, wire-wound, 250,000 ohms, with holder (Mullard). 1 Grid leak, 2 megohms (Dubilier). 1 Grid leak, 0.25 megohm (Dubilier). 2 Ribbed ebonite formers (Becol). 2 Paxolin tubes, 3in. dia., 3½in. long. 3 "O" size cells (Ever-Ready). 2 Grid leak holders, porcelain (Bulgin). 1 Cabinet (A. B. Clarke, 22, Old Montague St., London, E.1). Aluminium sheet, wire, screws, nuts, ebonite rod, etc. |
|---|--|

Approximate price, £8 17 6.

In the "List of Parts" included in the description of *THE WIRELESS WORLD* receivers are detailed the components actually used by the designer and illustrated in the photographs of the instrument. Where the designer considers it necessary that particular components should be used in preference to others, these components are mentioned in the article itself. In all other cases the constructor can use his discretion as to the choice of components, provided they are of equal quality to those listed, and that he takes into consideration in the dimensions and layout of the set any variations in the size of alternative components he may use.

and ½ in. by distance pieces cut from ebonite tube. The pair of aerial-grid coils are carried on ebonite rod supports 1½ in. long; these are tapped to take a 1 in. length of ¼ B.A. studding which is passed through the platform. A similar method of mounting is adopted in the case of the short-wave H.F. transformer; the supporting ebonite rods are slotted to a depth of ¾ in. at their upper ends to take the coil former, and tapped holes are drilled at the other end for the screws which secure the assembly to the platform. The supporting rods are 1½ in. long; thus the lower end of the coil former is raised 1 in. above the base. As the long-wave intervalve coupling is wound on a ribbed ebonite former of greater length, it is fitted in a simpler manner by filling in the end with a wooden disc, through which a single screw is passed.

As space in the left-hand (or input) side of the vertical screens is limited, a small economy was effected by filing

down the head of the large brass screw which secures the rotating ebonite barrel of the switch to its framework, thus preventing this screw making contact with the variable condenser end-plate.

It will be observed that porcelain connectors are used instead of terminals, as they are particularly suitable in a receiver where metal is largely used in construction. They should be regarded rather as connecting points for the various battery leads than as terminals in the ordinary sense, as they are somewhat inaccessible. This difficulty may be overcome, however, by fitting in each of the brass insets an ordinary valve leg, which will project through clearance holes drilled in the back of the cabinet. To avoid the need for an extra connector, the leads to L.T. negative, H.T. negative and grid bias positive are taken from a common point.

(To be concluded.)

TELEVISION—A PROMISE.

RECENT advertisement announcements in the daily Press have stated that the Baird Televisor is to be exhibited at the forthcoming Radio Exhibition at Olympia in September, while arrangements have been made for holding public demonstrations in an adjoining building. These announcements also point out that from September onwards the "Seeing-in" set will be available on the market for probably as little as £25 and with it moving images may be received at home from a broadcasting station. The Baird Televisor is to be purchasable either as a separate instrument or in combination with a listening-in set so that the possessor may be able both to see and hear the performance at the television broadcasting station. It is also stated in the announcement that with the perfection obtained, the marketing of the Baird Televisor is now ready to take its place in the commercial field with the prospect of commanding sales commensurate with those of the wireless instrument and the gramophone.

The past week has also seen the publication of the prospectus of Baird International, Ltd., a company having a share capital of £700,000, with Lord Ampthill as chairman. This new company acquires the rights in the Baird inventions and patents held by the Baird Television Development Co., Ltd., a company having a nominal share capital of £125,000. The Baird inven-

tions are stated to embrace (1) Television—to enable vision of living and moving beings, objects and scenes to be transmitted by wireless or land line in a manner similar to that in which sound is transmitted by wireless and telephony; (2) Noctovision—a name applied to the application of infra-red rays to the Televisor to enable vision in total darkness to be demonstrated; (3) Phonovision—the recording of a "television sound wave" in conjunction with music and reproduction from the record on a "Phonovision" screen of the actual moving scene as originally recorded; (4) Facsimile Telegraphy—the sending of pictures by a slowing down of the television equipment; (5) Automatic synchronism—a device whereby the transmitting and receiving apparatus are automatically kept in step. It is claimed that by this device costly synchronising equipment such as synchronous motors or elaborate tuning fork and oscillatory circuits can be completely dispensed with and the apparatus rendered simple for home use in an inexpensive form.

The directors prefer not to state any definite estimate of profits accruing from the sale of television receiving equipments. Success attended the issue of the 1,000,000 "A" shares of the company of 5s. each, offered at a premium of 1s. per share, and the lists were closed at 10.30 a.m. on the day of issue.

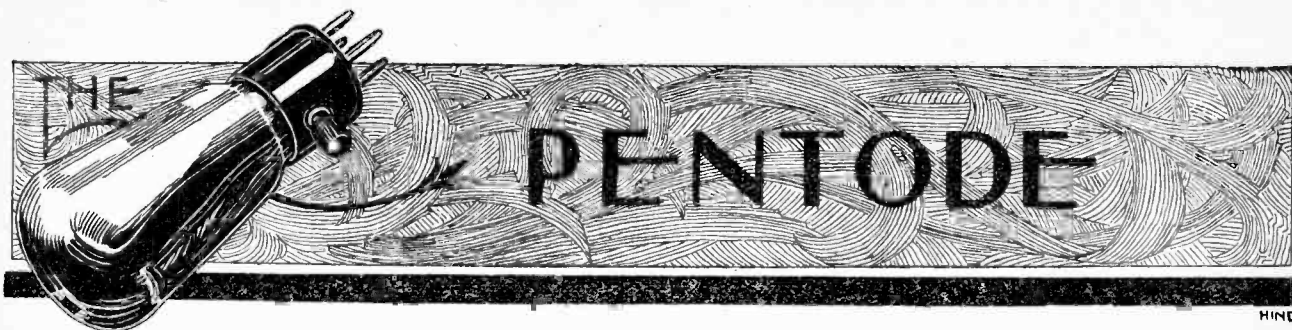

The Working Principles of a New Screened Grid Power Output Valve Explained.

By W. I. G. PAGE, B.Sc.

PROBABLY no component exercises more influence in the development of the wireless receiver than the thermionic valve. In the march of progress improvements have followed in rapid succession; for instance, we accept for granted the dull emitter filament with such small consumption that the heavy large-capacity accumulator bugbear has vanished. The screened-grid four-electrode valve has minimised high-frequency oscillation troubles, and the indirectly heated cathode valve has not only overcome the difficulty of A.C. filament supply, but has provided us with such remarkable characteristics that we may safely prophesy its more extended application in the near future. And now the Pentode.

Large Power Output.

We will first describe what the valve does and afterwards how it does it. The Pentode is a five-electrode power-output valve with a high magnification factor, but in which the usual low mutual conductance associated with high magnification valves has been avoided. A triode having a magnification factor of 50, for instance, will seldom have a mutual conductance of over about 0.6 milliamp per volt, whereas it is possible with a Pentode to retain a very high magnification factor with a mutual conductance of between 2 and 3 milliamps per volt, so that the *power output* of such a valve is large when quite a small signal potential is impressed on its grid; a feature of the valve is its heavy anode current.

One of these valves can replace the two L.F. valves usually employed in a set designed to give adequate

loud speaker reproduction, or, alternatively, in a receiver where there is only one L.F. valve its replacement by a Pentode would mean much louder signals, provided always that the input signal potentials did not override the permissible grid swing. The valve in its present form would appear to be able to accommodate as much *input* potential as an ordinary power valve of the D.E.5 type, but not so much as a super-

power valve; its position in a set should always be in the output stage.

We must now trace the evolution of the Pentode from the triode. The latter has one serious shortcoming which prevents the working mutual conductance of a high magnification factor valve being high enough to warrant the use of such a valve in the output stage. The reason is as follows: when an oscillation is impressed on the grid a rise in grid potential will be accompanied by a rise in anode current, but this rise in anode current will cause a drop in potential across the impedance in the external anode circuit (e.g., a choke or resistance which must be present for amplification purposes). A little thought will show that the

plate voltage fluctuation, which is in opposite phase with the input grid voltage, will have the effect of reducing the anode current to a figure considerably below that shown in the ordinary static curve. To put it briefly, the plate current in a triode under working conditions is increased by rising grid volts in accordance with the ordinary grid-anode curve (A B C, Fig. 1), but is reduced by the plate volts falling sympathetically as is seen by reference to the anode volts-

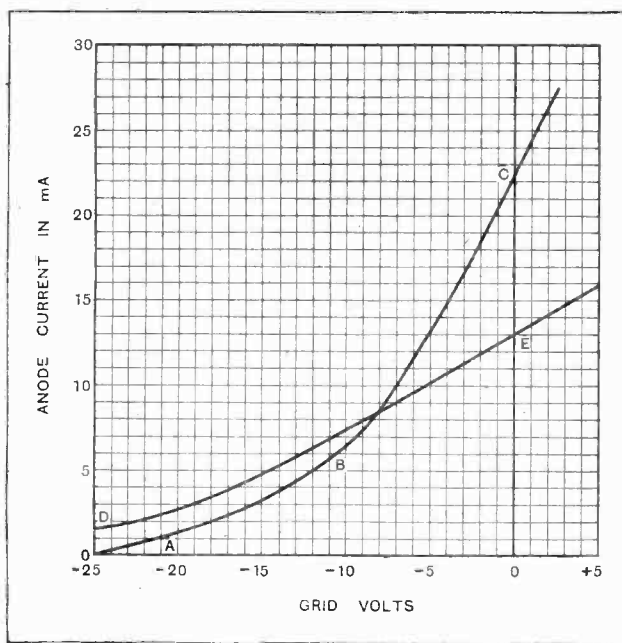

Fig. 1.—A typical triode static characteristic (showing mutual conductance) is represented by A B C. When an inductive load is applied to the plate circuit, the working characteristic would be represented by such a curve as D E, where the slope is much less. This is a shortcoming of the triode.

The Pentode.—

anode current curve A H (Fig. 2). Hence one reason for the difference between static and working curves.

In Fig. 1 A B C represents the ordinary grid volts-anode current characteristics of a triode taken under static conditions; as soon as a load is put in the plate circuit (and such load will be inductive with an output valve) the characteristic is represented by such a curve as D E. It will be noted that the curvature is less and that the steepness (*i.e.*, the milliamps per volt or mutual conductance) is also less. If by some means

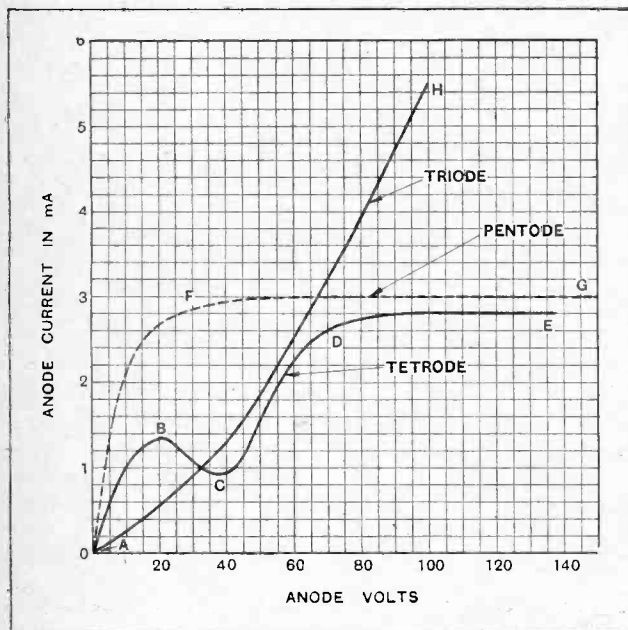

Fig. 2.—Anode volts-anode current curves for triode, screened grid tetrode and screened grid Pentode. The curves are imaginary, for where they are horizontal the valve would have an infinite magnification factor and impedance which is, of course, not realised in practice.

we were able nearly to retain the steepness of the slope of A B C under working conditions, together with a high magnification factor, we should obtain a valve of greater potentialities for low-frequency work.

The Screened Grid Characteristic.

In Fig. 2 A H represents a typical anode volts-anode current curve for a triode. It will be seen that for every volt rise in applied potential there is a rise in anode current, and the relationship between the two is nearly linear, with the result that the greater the plate volts change for a given grid volt change, the greater will be the anode current change tending to reduce the steepness of the grid volts-anode current (mutual conductance) characteristic. Unfortunately this influence is increased more and more as the magnification factor of the valve becomes greater.

This somewhat serious limitation of the three-electrode valve could be overcome were we to have an anode volt-anode current curve such as A F G (Fig. 2), which is for the most part horizontal. Here a change of plate volts between, say, 30 and 150 would cause no change in anode current, and the mutual conductance would

be very little altered as compared under static and dynamic conditions.

How are we to obtain this characteristic? The answer is to convert the triode into a tetrode, where the added electrode is between the control grid and the plate (we are not concerned in this article with the tetrode in which the blanket of free electrons—or space charge—around the filament is reduced by an added inner grid). The full explanation as to why the extra electrode, which is kept at a constant high positive potential, flattens the curve out to a nearly horizontal line has been published previously; but, roughly, if we consider that the filament, inner and outer grids form a three-electrode valve and that the outer "screening" grid is a very fine-mesh anode, we can well imagine that the real anode, which is outside the screening grid, cannot produce enough attractive influence on the electrons from the filament to produce any separate current of its own, but that it can well attract electrons from the screening grid.

An Earthed Auxiliary Electrode.

Therefore as the anode volts rise the current rises rapidly (see curve A F, Fig. 2), but as soon as the anode has robbed the screening grid of practically all of its electrons, and since we have stated that it cannot produce any separate current for itself, we find that a further increase in anode potential produces no increase in current (see curve F G, Fig. 2).

If a tetrode could be made to this specification we need worry little further, for we should be able to have a high magnification output valve with high mutual conductance—a thing for which we have striven from the beginning of this article. There are, unfortunately, as every reader knows who has handled the ordinary H.F. screened grid valve, certain secondary effects which limit its use and restrict us to a small portion of the anode volts-anode current characteristic. When a metal surface is subjected to electron bombardment, secondary electrons are liberated; in a triode this usually causes no tangible results, as the electrons find their way back to the anode, but in a four-electrode screened grid valve there are relative conditions of applied voltages when the secondary electrons are attracted to the screening grid

and cause a temporary decrease of anode current for a rise of plate volts (so-called negative resistance effect). The kink B C D in the curve A B C D E (Fig. 2) exemplifies this, and represents a theoretical curve for a screened grid valve where only the plate volt swing between D and E is available for linear amplification—not enough for large signal oscillations such as exist in the output stage of a loud speaker receiver. The valve just

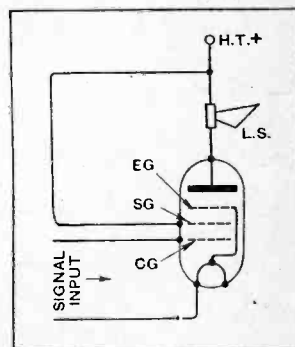

Fig. 3.—The electrode connections of a typical Pentode output grid valve. CG is the control grid; SG the screening grid which is connected to max. H.T. positive and EG the earthed grid which is connected internally to the centre point of the filament.

The Pentode.—

discussed has, therefore, been developed for high-frequency work where plate voltage swings are smaller, and grid swings may be one or two volts; attention has also been paid to the electrostatic shielding powers of the screening-grid which will be unnecessary in an output valve.

To obtain a liberal anode current from the screened grid valve, such as one would require for L.F. amplification, it is desirable to increase the potential on the screening grid, but it is obvious that when the plate voltage swings from maximum to minimum, unless the standing plate potential be excessively high, there will be an instantaneous low value of plate potential which will be below the steady screened grid potential, and both primary and secondary electrons near the plate will be attracted to the screening grid and the current in the latter will rise at the expense of the plate current. This explains the limitations of the screened grid tetrode for L.F. amplification.

Some expedient is required whereby the kink in the curve is avoided, and whereby the screening grid can be kept at a higher steady potential to give greater anode current without the phenomenon occurring whereby the screening grid robs the plate of its current. The remedy

is the interposition of an earth-connected third grid to form a five-electrode valve or Pentode. This extra electrode is placed between the screening grid and the anode and allows the electrons by reason of their velocity to pass in the normal direction to the plate, but reversal of direction of primary and secondary electrons to the screening grid, which will undoubtedly be periodically at a higher potential than the plate, will be prevented, since their velocity is much less and is adequately reduced by the zero field around the earthed grid. The curve A F G (Fig. 2) is the ideal characteristic for a Pentode, the electrode connections of which are given in Fig. 3. Messrs. Mullards have designed Pentodes (under the commercial name of Pentones) for 2- and 4-volt accumulators. They will not, however, be available for the experimenter for about two months. Practical tests are being carried out with these valves, and a report will be published in next week's issue. It is understood that a series of Osram and Marconi Pentodes have now completed their tests, and will be on the market shortly before the Olympia Exhibition. It would appear safe to predict that the remarkable constants obtainable with the five-electrode valve will be incorporated in valves suitable for every position in a receiver.

EARTHING TUBE CONNECTIONS.

One of the most widely used devices for providing the earthing system for an ordinary wireless receiver consists of a perforated copper tube which is driven into the ground, a screw and a washer being situated at the top end of the tube for attachment to the end of the earth wire from the set. Usually such screws are totally inadequate to enable them to obtain a firm grip on the earth wire, which usually consists of several strands of wire as in

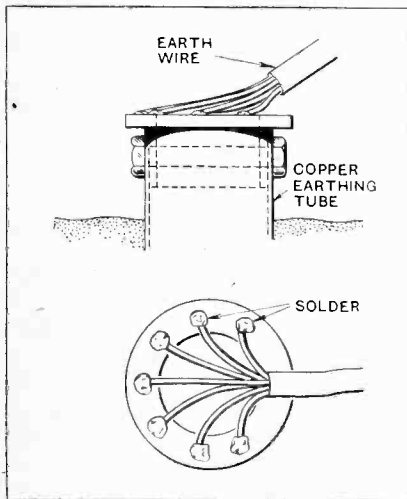

Efficient method of uniting earth wire and tube.

**NOVELTIES FROM
OUR READERS.**

the case of an aerial wire. Apart from this, such a connection rapidly corrodes, and the resistance of the whole earthing system rises considerably, resulting in a great loss of efficiency in the receiver. The trouble can, however, be overcome by separating out the strands of the earthing wire and soldering them to the ring situated at the top of the earthing tube in the manner shown. E. W.

FIXING THE AERIAL MAST.

In most cases the breaking of the halyard passing through the pulley of the aerial mast and supporting the aerial wire means that the mast will have to be taken down. Many amateurs have anticipated this trouble by mounting their aerial pole on a pivot in such a manner that it can be easily lowered when required.

If, as often happens, there is a shed of some type at the far end of the garden, this method of fixing the aerial pole is greatly simplified as shown. Two 1/2 in. bolts of sufficient length to pass through the aerial mast and the corner post of the shed

should be obtained, and the first bolt should be placed through the mast and the top of the chosen corner post, and it is on this bolt that the mast pivots. The second bolt passes through the mast close to its lower end, and through the lower part of the corner post. The butt of the mast will be thus raised a few inches from the ground, and to lower it down it is only necessary to withdraw the lower bolt, using the upper bolt as a pivot, as already stated.

W. M. H.

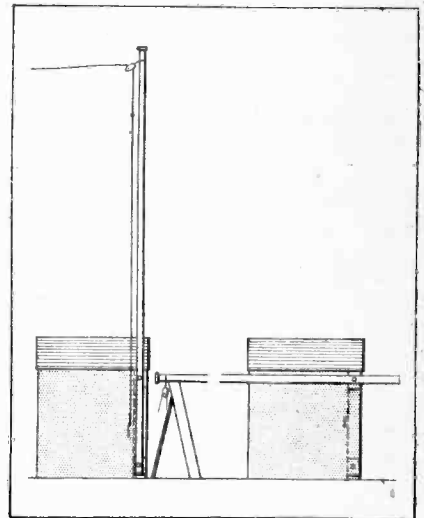

Aerial mast pivoted by bolt to corner post of shed.

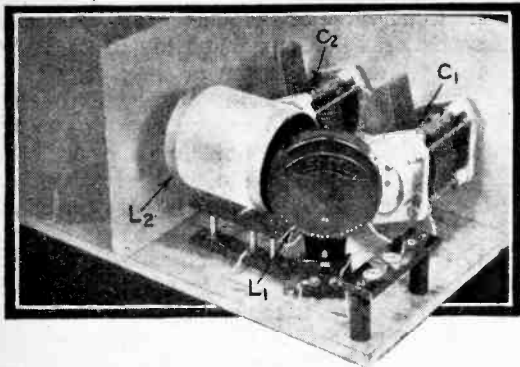

LOOSE-COUPLING

Some Notes on Two-circuit Tuners.

By "RADIOPHARE."

common turns is from one-sixth to one-twelfth of the total in the secondary; the exact position of the tap depends on the selectivity required, and on other factors, and is best ascertained by trial. The aerial loading coil L_1 should not be in inductive relationship with L_2 .

The primary condenser should, strictly speaking, be larger than that which tunes the closed circuit, in order to compensate for the effect of the aerial capacity, which is in parallel with it. However, a maximum of 0.0005 mfd. will do quite well, and, provided the coil is chosen carefully, it should be possible to cover the majority of the normal broadcast waveband without changing it. A definite recommendation as to size cannot be given, due to variations in aerial capacity, but a 40-turn inductance will generally be about right for the more popular circuit shown in diagram (a).

Weakest Coupling Generally Best.

Most of the difficulties encountered in operation are due to too-frequent alteration of the relative positions of

the two coils, which results in variation of tuning in each circuit. It is best, once a good average coupling has been found, not to change it unless special circumstances require extra selectivity. As a rule, this "best coupling" will be surprisingly weak, the axes of the two coils being nearly at right angles. On no account should it be tightened to such an extent that a station may be heard at two settings of

the condensers—the "double-humped" tuning effect.

As in operating any receiver with more than one control, the only real way to "search" for signals is to keep all circuits as nearly as possible in tune, following a slight movement of one condenser by a corresponding rotation of the other (or others).

When the set includes a stage of neutralised high-frequency amplification, it is strongly recommended, at any rate until complete mastery of its operation has been attained, that the circuit should be accurately balanced; any attempt to increase sensitivity by partial deneutralisation is likely to lead to puzzling complications. For instance, conditions may arise under which slight detuning of the aerial circuit actually increases signal strength, due to a decrease in the loading effect. Success with a loose coupler is largely bound up with the elimination of those factors likely to cause uncertainty.

THE present-day tendency towards the simplification of receiver design cannot but meet with general approval; the gradual disappearance of a multiplicity of controls has smoothed the path of the beginner, and, be it whispered, even of the expert, who often overlooks the proper regulation of an essential control when faced with a formidable array of knobs.

There is, however, one addition that the writer would prefer to call a refinement rather than a complication: this is a variably coupled and separately tuned aerial circuit. Admittedly, it is anything but popular among amateur constructors, but this is probably due to their failure to operate it correctly; although with a little patience and the right method of procedure, the art is not difficult to acquire. As compared with even the best modern "aperiodic" couplers (the design of which is essentially in the nature of a compromise) the increase of signal strength for a given selectivity will generally be aurally appreciable; indeed, the H.F. voltage applied to the first valve may be almost doubled when working on an indifferent aerial at certain wavelengths. Looking at the

matter from another aspect, the separately tuned circuit as a rule offers better selectivity with at least equal signal strength.

A conventional magnetically coupled arrangement is shown in diagram (a), and, as applied to a typical receiver, in the illustration at the head of this article, where aerial and secondary coils are marked L_1 , L_2 , and their associated tuning condensers, respectively, C_1 , C_2 . An optional "untuned" coupling is provided by connecting the aerial through terminal A_2 to a tapping point on the secondary coil. Diagram (b) represents the auto-transformer method, which is often convenient when loose coupling is being added to an existing set, as the additional apparatus may be mounted externally. A part of the coil L_2 is common to both aerial and secondary circuits; in general a suitable transference of energy will take place if the number of these

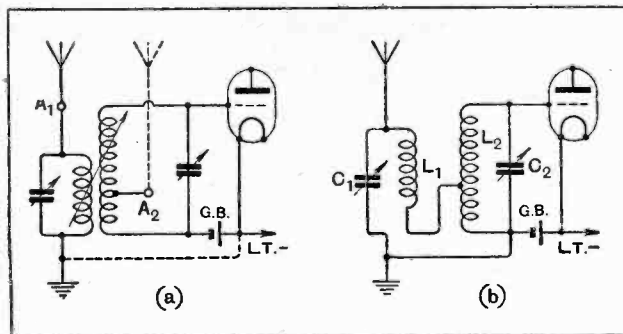

Inductively coupled tuner (a) and an auto-transformer circuit (b). An optional aperiodic aerial with earth connection is shown in dotted lines.

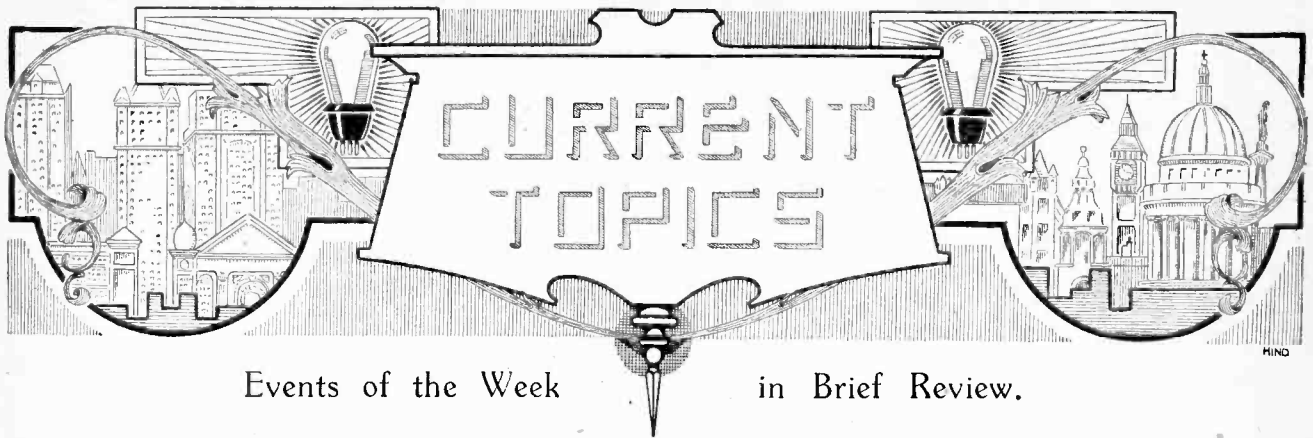

Events of the Week in Brief Review.

BIGGER WIRELESS SHOW.

This year's National Wireless Exhibition at Olympia, which opens on September 22nd, will contain at least 262 stands, compared with 229 last year.

EVIDENTLY A CONNOISSEUR!

A McMichael portable receiver was stolen by a person unknown from the company's showrooms in the Strand on Wednesday last, June 27th. The number of the missing set is 9817.

THE COUNTRY LISTENER.

"La Radio Agricole," a new French monthly magazine, is to be devoted to interests of country dwellers who use wireless. It is the organ of the Federation Nationale de Radiophonie dans les Campagnes.

OVERHEAD TROLLEY NUISANCE.

Listeners in Willow Road, Darlington, have addressed a signed protest to the Gas, Water and Electricity Committee in regard to the extraneous noises caused by trackless trolley cars. The B.B.C. has been invited to tender advice.

MORE LISTENERS IN POLAND.

During 1927 the number of receiving licences in Poland grew from 47,000 in January to 88,000 in August, states a report of the Commercial Secretary at Warsaw. It is believed that the figure reached 150,000 at the end of December.

WIRELESS "WHILE YOU WAIT."

A "Railway Broadcasting Company" was recently formed in Budapest for the purpose of providing broadcast receivers in station waiting rooms. A correspondent states that many waiting rooms are now equipped with loud speakers.

LICENCE-FREE WIRELESS IN CEYLON.

Efforts to encourage the use of portable wireless sets in the planting centres of Ceylon are being made by the Government, writes a correspondent in Kalatura, Ceylon. Among the steps taken by the authorities is the removal of the import duty on privately-owned wireless sets and any person may now import and possess a receiver for six months without a licence.

SUPER STATION FOR AUSTRALIA?

A proposal to establish a super-power wireless station at Canberra is under consideration by the Australian Government. Such a station would ensure a ready and reliable means of communicating with the rest of the Empire and would supplement the short-wave beam system.

RECORD SPEECH AMPLIFYING SYSTEM AT HENDON.

No fewer than 39 Marconiphone loud speakers were used for speech amplifying purposes at last Saturday's R.A.F. display at Hendon.

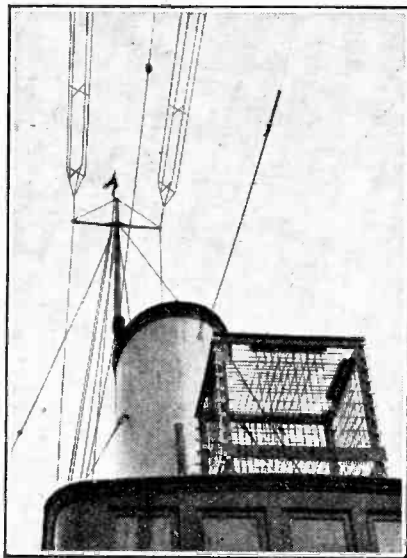

SENATORE MARCONI'S YACHT. The aerial and direction finder in the "Elettra," on which Senatore Marconi has recently conducted a number of tests in connection with beam transmission at sea.

play at Hendon. Hundred and twenty super-power valves were necessary, 96 of these being in the last stage, which consisted of three large power banks of 32 L.S.5A's each. Ten miles of wiring were used, in what is understood to have been the largest system of its kind ever installed in this country.

B.I.F. 1929.

The British Industries Fair for 1929 will contain a 40 per cent. increase in the number of stands as compared with this year's Fair. Wireless firms were well represented at the 1928 Fair, and it is expected that there will be no diminution in their numbers in 1929. The Fair will be held in February.

HOPE FOR THE HOLIDAY MAKER.

Holiday-makers who have left their wireless sets at home may still have an opportunity to listen to the programmes if they choose one of the resorts to be visited by the steam yacht *Ceto*. The *Ceto*, which has been chartered by the *Daily Mail*, is touring the coast of the British Isles with a cargo which includes two loud speakers and a powerful broadcast receiver. At the various ports of call the *Ceto* will entertain holiday-makers with selections from the B.B.C. programmes.

SELECTIVITY TAKES SECOND PLACE IN U.S.

Receiving sets and components valued at £250,000 were on view at the fourth annual convention of the Radio Manufacturers' Association of America, recently held in Chicago. The design of sets showed a tendency to concentrate on good reproduction of the whole musical scale, less attention being paid to selectivity, which has become of secondary importance in view of the careful reallocation of broadcast wavelengths by the Federal Radio Commission.

GERMANY'S EQUAL-WAVE STATIONS.

Berlin listeners are still speculating as to the probable site of the projected equal-wave broadcasting station which is to replace the well-known station in Magdeburg Square. It has been found that the Lichtenburg district, an eastern suburb of Berlin, is unsuitable for technical reasons.

Three equal-wave broadcasting stations are to operate in the Berlin area, but judging from the recent failure of Birmingham and 5AB to work on the same wavelength without heterodyning, the experiment is not a promising one.

RADIO REFERENDUM IN SWEDEN.

Sweden, who now heads the world in regard to the number of wireless licences issued, viz., 57.8 per 1,000 inhabitants, is about to build two new broadcasting stations. One will be erected outside Stockholm with a power of up to 50 kW., and the other at Hoerby, in the southern province of Scania, with a strength of 10 kW.

Recently the Broadcasting Bureau of the Swedish Telegraph Board asked registered radio listeners to write down their ideas about the radio programmes sent out. The result has been that 140,000 radio users have expressed their views to the bureau, which is now carefully sorting out the replies.

State. We are indebted to the High Commissioner of the Irish Free State in London for the following information:—

Under the Free State Wireless Telegraphy Act, 1926, no person may keep or have in his possession any apparatus for wireless telegraphy without a wireless licence, the fee for which is 10s. per annum. In the case of a person bringing a wireless set into the country, the licence should be taken out at the Money Order Post Office nearest to the address at which the apparatus is to be kept.

As regards Customs duty, if the owner of the wireless set is a resident of the Irish Free State the instrument will be admitted only on payment of a duty at the rate of 33½ per cent. *ad valorem*.

the pilot to operate and adjust the apparatus when flying.

The Marconi type AD6h telegraph-telephone equipment for aircraft is familiar to most people in aviation circles, and is standard equipment on Imperial Airways machines as well as those of many other air lines. Over 1,400 of these sets are now in use on commercial, military, and naval aircraft in all parts of the world.

o o o o

MAJOR FITZMAURICE ON AIRCRAFT WIRELESS.

The importance of wireless in transatlantic flight endeavours was recently emphasised by Major Fitzmaurice, who accompanied the German aviators in their flight across the Atlantic in the "Bremen."

"That the 'Bremen' carried no wireless was the one weak point in the organisation of the flight," said Major Fitzmaurice in a recent interview. "As we now realise, had we had a wireless set on board upon our estimated arrival in the neighbourhood of Newfoundland we could have been given almost an exact position by direction finding stations along the coast, have been informed of the precise direction and velocity of the wind over the sea, and would have made New York easily with our objective accomplished."

TRANSMITTERS' NOTES AND QUERIES.**Reports Wanted on Sheffield Tests.**

Mr. E. S. Elliott (G5LT), 13, Merlin Way, Firth Park, Sheffield, is carrying out tests in connection with the alteration of skip in conjunction with reduction in power input and will be glad of reports from listeners within a range of twelve miles and between 150 to 200 miles from his station. Tests are carried out on 23 and 45 metres on Sunday mornings from 11.0 to noon with a T-P, T-G circuit and a Hertz aerial and usually with an input of 5 watts.

o o o o

On the Ultra Short Waves.

A licence for transmission on 5, 10, 21, 23 and 32 metres, as well as the longer waves, is now held by Mr. A. M. Houston Fergus (TBA), of La Cotte, La Moye, Jersey, C.I.

The strenuous efforts which American amateurs are making to vindicate short waves of the order of 5 and 10 metres are being carefully watched, and there is a growing band of British amateurs who are determined that the spoils shall not all go across the Atlantic.

o o o o

New Call-signs and Stations Identified.

- 2LV (Ex 2ANT) V. Leach, White House, Hucclecote, Gloucester, transmits on 150-200 metres and will welcome reports and co-operation.
- 2AYO R. Brettell, 3a, Hartshorn St., Bilston, Staffs.
- 6WT Dr. J. R. Wortley-Talbot, Broadlands House, Churston, Devon.
- 6MO (Ex 2AOV) A. E. Apps, 322, High St., Chatham, transmits on 150 metres and welcomes reports.
- 5LT E. S. Elliott, 13, Merlin Way, Firth Park, Sheffield, transmits on 23 and 45 metres.

A 22

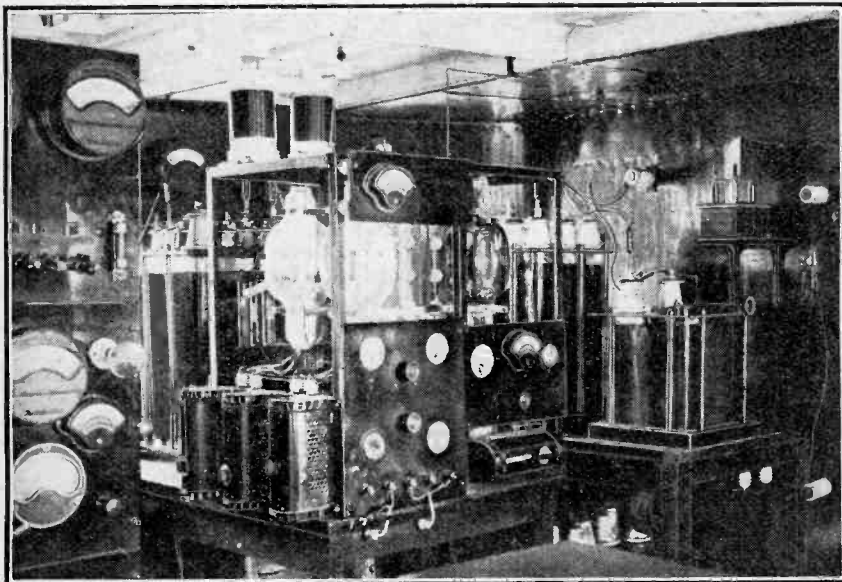

THE TRANSMITTER ON THE "ELETTRA." A recent photograph, taken in the wireless cabin of Senatore Marconi's yacht.

CAPT. COURTNEY'S OPINION.

The machine with which Captain F. T. Courtney is attempting his "both ways" Atlantic flight, a Napier-Dornier-Wal flying boat, is equipped with Marconi wireless transmitting and receiving apparatus to enable the flyers to keep in touch with ships and with shore stations throughout the flight.

The object of the flight is to demonstrate the practicability of transatlantic air services carried out by flying boats, and for the operation of such services on a commercial basis. Captain Courtney declares that wireless—which is standard equipment on all Imperial Airways machines—is essential.

o o o o

TAKING A PORTABLE TO SOUTHERN IRELAND.

The tourist with a portable set needs to be armed with information concerning the importation of wireless sets in foreign countries. The current regulations in the nearer European countries were dealt with in our issue of June 20th, but no mention was made of the Customs conditions obtaining in the Irish Free

If, however, the owner is not a resident and the instrument is being imported during a temporary visit to the country and to be subsequently exported, admission will be allowed free of duty on a declaration being made on Form 104 in the presence of an officer of Customs and Excise at the place of importation.

o o o o

WIRELESS AT PARIS AERO SHOW.

British wireless apparatus for aircraft is represented at the Aero Show now open in Paris by a Marconi type AD5 and 12 set fitted in a single-seater fighter on the Bristol Aeroplane Company's stand, and a Marconi type AD6h set on the stand of a French exhibitor, Marabini Aviation.

The AD5 and 12 set requires no trailing aerial, the whole of the aerial system being permanently attached to, and insulated from, the wings and fuselage of the aeroplane. The apparatus is extremely compact and the remote control arrangements provided enable it to be mounted anywhere in the machine without interfering with the ability of

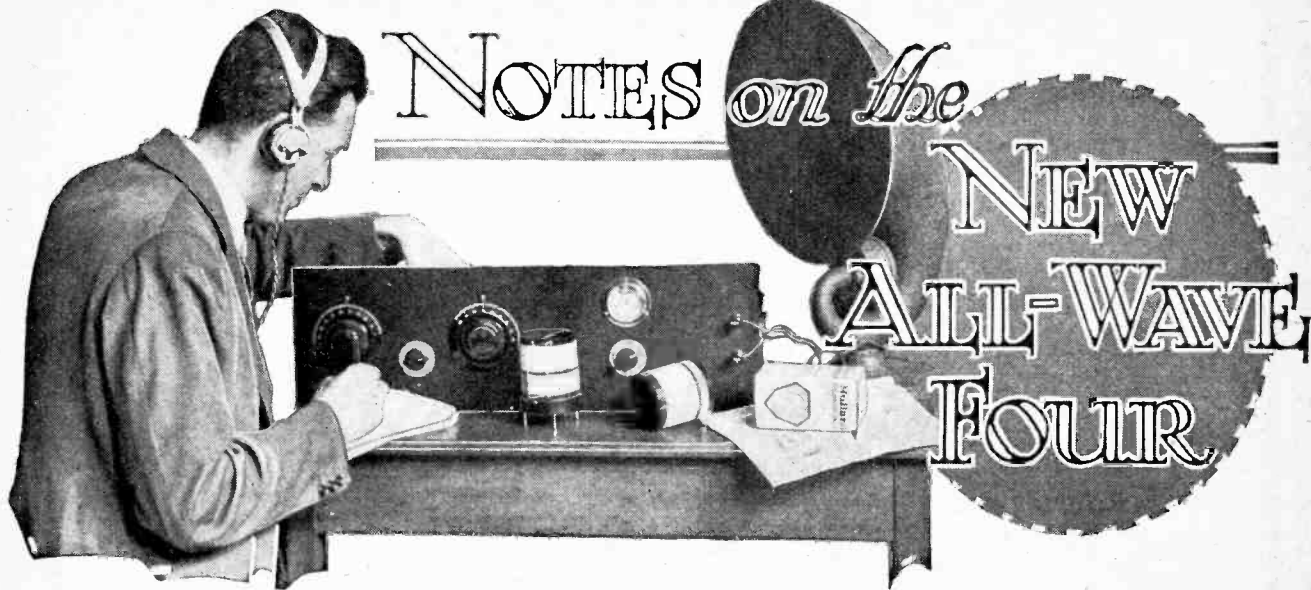

Some Unusual Features Explained. By N. P. VINCER-MINTER.

THE fact that the straightforward type of receiver, enabling a fair number of European broadcasting stations to be received with good strength and quality without the need for complicated tuning arrangements, is still held in high favour by wireless enthusiasts, is readily shown by the large number of enquiries received concerning the "New All-Wave Four" receiver published in a recent issue of this journal.¹

An explanation is required concerning the two protective resistances marked R_7 and R_8 in various diagrams appearing in the original article.

Assuming for the moment that the resistance R (Fig. 1) is not there, we have a plain, straightforward arrangement.

Now if we remove the wander plug from its socket in order to effect a change in grid bias at a time when the H.T. and L.T. are switched on, or, in other words, if we "break" the grid circuit at such a time, it is obvious that the effect will be that all bias is removed from the grid, and the plate current, therefore, increases rapidly, and a strain is thrown on the emissive properties of the valve filament. This process need not be repeated many times before the efficiency of the valve is seriously undermined, and yet how often does the average wireless man trouble to safeguard his valves by switching off the H.T. supply every time he makes a change in grid bias? This process of breaking the grid circuit is as equally destructive to the efficiency of the valve as is the repeated temporary connection of the valve filament across a battery of higher voltage than specified by the makers, such as, for

instance, the repeated application of a two-volt valve across a three-volt source of supply.

All risk of breaking the grid circuit, and all the trouble of switching off the filament can be avoided by putting a simple 5-megohm leak R in the position shown in Fig. 1. It will be at once seen that if the grid bias plug is lifted, the grid circuit will still be continued through R, and that the anode current will not rise. Obviously, by employing another resistance, the same safeguard may be used in conjunction with the penultimate valve.

It would seem that the only disadvantage is that some section of the grid battery in Fig. 1 is continuously short-circuited by the 5-megohm resistance.

Now, supposing that the resistances were connected across the whole of the customary 16½-volt grid battery, Ohm's law tells us that the current flow will be only three-thousandths part of one milli-ampere, or, in other words, three microamperes. If we have two valves, as in the case of the "New All-Wave Four," the current would be six microamperes. This current is so small that for all practicable purposes it might not be there at all, and the life of the grid battery will be found equal to the life which it will have if stored upon a shelf. Actually, of course, the current will be lower than six microamperes, as the resistances do not

shunt the whole of the battery. It should not be forgotten that since no grid current will be flowing, there are no volts dropped across the resistance R in Fig. 1; and this applies no matter how high we make the resistance.

It will be noticed that a 4 : 1 ratio transformer is used

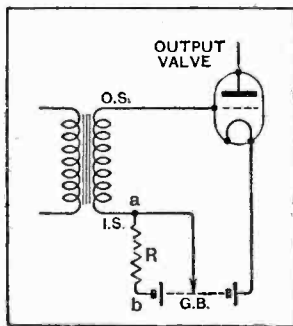

Fig. 1.—This diagram clearly indicates the technical principle underlying the use of the protective resistance R.

¹ *The Wireless World*, June 13th, 1928, page 622.

Notes on the New All-Wave Four.—

instead of the 2.7:1 instrument by the same makers. The 2.7:1 instrument has, of course, a primary of greater inductance than the one used, and undoubtedly the lower musical tones would be more greatly emphasised if we employed it. On the surface it would appear, therefore, that we are deliberately throwing away good quality. This is not so, however, for it must be remembered that this receiver is extremely selective. In other words, the tuning is sharp, and the result is that side bands are apt to be affected. Now the result of using sharply tuned circuits and so tending to cut side bands is to boost unduly the lower musical notes at the expense of the upper ones. This brings about a sense of lifelessness in music and woolliness of speech.

The presence of the shunting condenser C_6 , which is virtually in parallel with the anode resistance of the detector, causes an increased loss of the high notes and musical harmonic amplification. Needless to say, the

sufficient to cause even an insensitive pick-up to overload the final valve slightly (unless the volume control on the pick-up is brought into use), and everybody will admit that the majority of the pick-ups at present on the market are far from being insensitive.

Distortion Revealed by the Milliammeter.

The connection A_2 is for use on the local station. The best value for C_4 will usually be found to be 0.0001 mfd. Since this condenser is of the "clip-in" type, it is easily removed, and, therefore, as it is, electrically speaking, hanging on to the grid of the detector valve, many may care to unclip it when searching for really distant stations, although the writer assures them that careful work with a valve voltmeter indicates that this is unnecessary. The condenser can be seen in the photograph illustrating the back of the receiver, mounted just behind the H.F. transformer.

The milliammeter in the plate circuit of the last valve

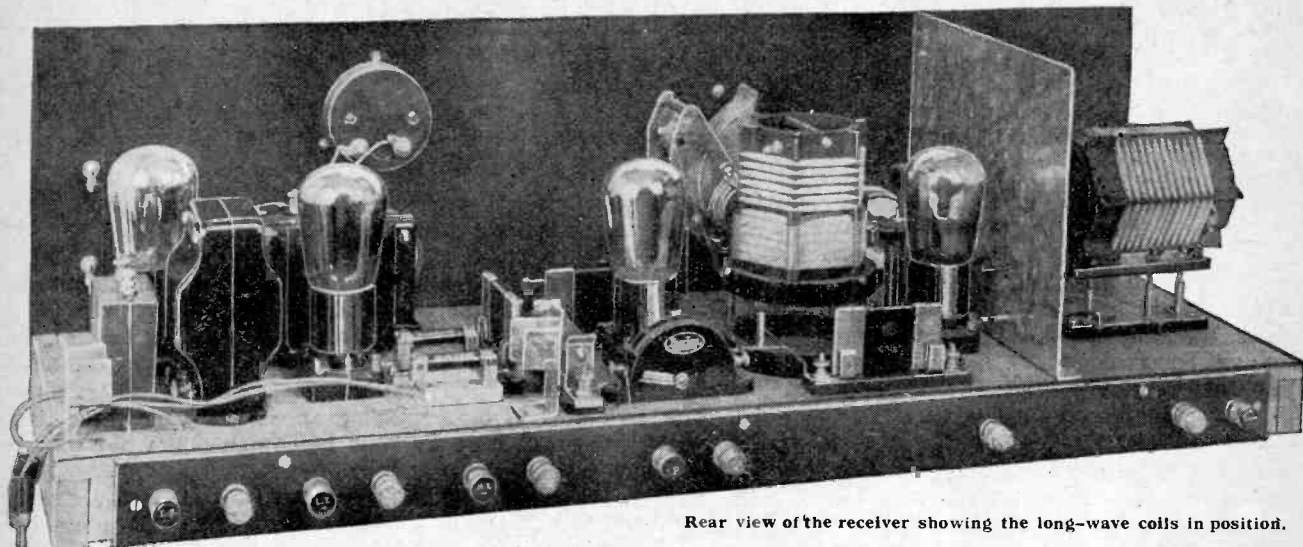

Rear view of the receiver showing the long-wave coils in position.

condenser is necessary to give efficient rectification, but its value must be kept as small as possible.

The partially suppressed higher notes can be restored by using a transformer of low primary inductance.

Provision for Gramophone Pick-up.

It will be noted that the gramophone pick-up terminals are connected across the grid filament path of the first L.F. amplifier instead of being inserted in the grid circuit of the detector valve as is more customary. Connecting the terminals in the position in which they are arranged in the "New All-Wave Four" not only gives us the small advantage that grid bias is already correctly adjusted (for, of course, the valve is already an amplifier), but gives in addition the advantage that we shall get far better reproduction due to the absence of overload of the last valve. There is a certain school of thought who might raise objections that insufficient amplification is obtainable by this method of connection. This is quite wrong, however, since it must be remembered that V_3 in conjunction with the transformer gives us a seventy-fold amplification, and is, therefore,

is, of course, for the purpose of indicating distortion due to overloading of the last valve, and will, therefore, be of equal use irrespective of whether wireless reception or gramophone reproduction is being carried out. The telephone terminals are for the purpose of enabling a search to be made for distant stations on the telephones without disconnecting the loud speaker. Since they are in series, which is the proper position for them, they should be short-circuited when not in use. However, even if telephones are left permanently connected to them, no appreciable diminution will be heard in the volume obtained from the loud speaker.

With regard to what is sometimes known as the anode feed scheme, and sometimes as the L.F. stabilising scheme, which is represented in the original receiver by the resistances R_9 , R_{10} , and R_{11} , and by the condensers C_9 , C_{10} , and C_{11} , it is impossible to deal with this briefly, and it was for this reason that a complete article was published concerning this, giving full details of the system on page 439 of our April 25th issue. Readers who hope to understand this system *must*, therefore, refer back to this article.



PROGRAMMES

FROM ABROAD

Saturday, July 7th.

All Times are reduced to British Summer Time and are p.m. except where otherwise stated.

PARCELONA (Radio Barcelona), Call EAJ1 (344.8 metres); 1.5 kW.—6.0, Exchange Quotations. 6.10, Instrumental Sextet Music. 8.30, Advanced French Lesson. 9.0, Exchange Quotations and News. 9.5, Orchestral Selections: Overture to La Bulerie (Suppé), Sardana, La processó de Sant Bartomeu (Catala), Selection from Pau y toros (Barbieri), Noche de amor (Delmas), Petit bolero de concert (Ross). 10.5, Programme from Madrid, EAJ7. 12.30 a.m. (approx.) (Sunday), Close Down.

BERGEN (570.4 metres); 1.5 kW.—8.0, Relay from the Norwegian Young People's Assembly. 9.0, Recitation by Sverre Erichsen. 9.30, Talk: Hardanger. 10.6, Weather, News and Time. 10.15, Musical Programme from the National Exhibition. 12.0 Midnight (approx.), Close Down.

BERLIN (Koenigswusterhausen) (1,250 metres); 40 kW.—6.30, Elementary Spanish Lesson. 6.55, Illustrated Talk: "Grotesque" in Piano-forte Music. 7.20, Talk: Goethe and Art Treasures of his Time. 8.30, Programme from Voxhaus. 12.30 a.m. (approx.) (Sunday), Close Down.

BERLIN (Voxhaus) (484 metres); 4 kW.—10.10 a.m., Retail Food Prices. 10.15 a.m., Weather Report, News and Time Signal. 11.0 a.m., Gramophone Selections. 11.30 a.m., Exchange Quotations. 12.55, Time Signal, Weather Report and News. 3.0, Exchange Quotations. 8.10, Agricultural Prices and Time Signal. 8.30, Gramophone Selections. 4.0, Dr. Paul Frank, Talk: Medical Hygiene. 4.30, Dr. Rolf Friedlaender, Talk: Boat-racing. 7.0, Dr. August Bock, Talk: Obsolete Laws on Economics. 7.30, Fritz Winters, Talk: Official Work in the Everyday Life of the Public. 8.0 Talk by Dr. A. Guttman. 8.30, "Halbzeit," Play (Bronnen and Braun), followed by Weather Report, News, Time Signal and Sports Notes. 10.30, Dance Music. 12.30 a.m. (approx.) (Sunday), Close Down.

BERN (411 metres); 1.5 kW.—1.0, Time Signal, Weather Report, Exchange Quotations, and Light Gramophone Selections. 3.56, International Time Signal from the Neuchâtel Observatory. 4.0, Selections by the Kursaal Orchestra. 4.30, Nature Study Talk. 5.0, The Kursaal Orchestra. 8.0, Time Signal and Weather Report. 8.5 (approx.), Operetta Selections. 9.0, Relay of Women's Sports. 9.45, News and Weather Report. 10.0, Selections by the Kursaal Orchestra. 10.35, Dance Music. 12.0 Midnight (approx.), Close Down.

BRESLAU (322.6 metres); 4 kW.—6.30, See Koenigswusterhausen. 7.25, Advanced English Lesson. 7.50, Talk: Germany and the Other Nations (Lehmann) 8.30, "Tageszeiten der Liebe," Comedy (Nicodemus, trans. Kahu). 10.0, News and Announcements. 10.30, Programme from Voxhaus. 12.0 Midnight (approx.), Close Down.

BRUNN (441.2 metres); 3 kW.—7.0, Concert: Nature in Music, Meeresruhe (Mendelssohn), Selection from L'Arlesienne (Bizet), Songs (Schubert), Au Matin (Godard), Selection from Siegfried (Wagner), Songs (Schubert), Suite (Michiels). 8.30, Comedy Selection. 9.0, Exhibition Programme. 10.0, News from Prague. 10.25, Exhibition Programme.

BRUSSELS (508.5 metres); 1.5 kW.—5.0, Dance Music from the St. Sauveur Palais de Danse. 6.0, English Lessons. 6.45, Orchestral Concert: Selection from Ta Bouche (Yvain), French Comedy Overture (Keler-Bela), Melodie and Scherzetto for Clarinet (Coquart), It's Ray, Ray, Raining (Johnson), Dream Kisses (Gellen), Serenade (Schubert), Charleston (Stall), Dawning (Sylvester), Intermezzo Barcarolle for Horn (Dupont), Ballet des parfums (Popy). 7.30, Radio-Chronicle. 8.15, Gramophone Selections. 8.30, Piano-forte Recital: Prelude and Fugue (Bach), Sonata (Beethoven). 8.50, Topical Talk. 9.0, Concert relayed from the Kursaal, Ostend; News. 10.30 (approx.), Close Down.

BUDAPEST (555.6 metres); 35 kW.—9.30 a.m., News and Economics Notes. 12.0 Noon, News, Economics Notes, Chimes and Gramophone Selections. 1.0, Time and Weather. 3.0, News and Economics Notes. 4.0, Talk. 4.45, Time and Weather. 5.0,

Talk for Women, by T. Aranvi. 5.30, Orchestral Concert: Ballet Suite (Lully-Mottl), The Nutcracker Suite (Tchaikovsky), Sylvia (Delibes). 6.50, Gala Concert; in the Interval, Racing Results. 8.25, Concert by the National Post Office Music Society: Songs, (a) Aria (Gounod), (b) Aria (D'Albert); Sous sa fenetre (Hubay), Air from The Marriage of Figaro (Mozart), Air from Samson and Delilah (Saint-Saens), Concerto for Violin in D Minor (Vieuxtemps), Songs (Schumann), Czardas (Hubay), Alte Liebe (Brahms), Marian Wiegand (Roger), Enyegets (Csiky). 10.10, Time and News. 10.30, Scenes from Hungarian Folk Plays, with accompaniment by a Tzigane Orchestra. 12.0 Midnight, Close Down.

COLOGNE (283 metres); 4 kW.—5.0, Talk for Women. 5.30 to 6.55, See Langenberg. 7.20, Talk: Social Leaders of the past from the Rhineland and Westphalia, David Hansemann. 7.45, See Langenberg. 8.15, Variety Concert, followed by News, Concert and Dance Music. 1.0 a.m. (approx.) (Sunday), Close Down.

CRACOW (566 metres); 1.5 kW.—12.0 Noon, Gramophone Selections. 1.0, Chimes from the Church of Notre Dame, Time and Weather. 3.0, Weather and Talk on Economics. 5.0, Children's Programme. 6.0, Programme from Vilna. 7.0, Miscellaneous Items and News. 7.30, Talk by Mr. Regula. 7.55, Agricultural Report. 8.15, Programme from Warsaw. 10.30, Concert from a Restaurant.

DUBLIN, Call 2RN (319.1 metres); 1.5 kW.—7.20, News and Stage Reminiscences by Frank Fay. 7.45, Irish Talk, followed by "From the Gael" by the Station Orchestra. 8.20, Amhrain Ghaeilge. 8.35, Sonata in G Minor (Brahms) by Petite O'Hara (Violini) and Mrs. Boxwell (Pianist). 9.0, Musician Series Illustrated, by Walter Starkie, LL.D. 9.30, Doreen Thornton (Soprano). 9.45, Topical Events Talk. 10.0, Ceol ar an Bheidhinn. 10.15, The Station Orchestra. 10.30, News and Close Down.

FRANKFURT (428.6 metres); 4 kW.—6.15, Wireless Notes and Announcements. 6.30, Reading and Talk; Poems in Saarbrück Dialect. 7.0, The Letter Box. 7.15, Shorthand Lesson. 7.45, Astronomy Talk for July. 8.15, Duets for Violin and 'Cello: Duo (Mozart), Duo (Paul Hermann), Sonata da camera (Seiber), Roumanian Dances (Bartok). 9.15, Variety Concert from Cassel (252.1 metres), followed by Programme relayed from Voxhaus. 12.30 a.m. (approx.) (Sunday), Close Down.

HAMBURG, Call HA (in Morse) (394.7 metres); 4 kW.—5.0, Concert of Wedding Music by famous composers: Overture to The Marriage of Figaro (Mozart), Wedding March from A Midsummer Night's Dream (Mendelssohn), Air from A Rustic Wedding (Goldmark), Swedish Wedding March (Sodermann), Bridal Chorus from Lohengrin (Wagner), Dance of the Brides from Feramors (Rubinstein); Waltz, Wedding Rondo (Bilse). 6.0, Week-end Station Concert. 7.0, Talk: Work and the Importance of the Hamburg Students' Aid Centre. 7.25, Dr. Muhlbrecht, Talk: The Future Task of Polar Expeditions. 8.0, Concert, arranged by the Hamburg Police Force, followed by Weather and News. 10.30 (approx.), Concert from the Winterhuder Fabrihaus.

HILVERSUM (1,071 metres); 5 kW.—11.40 a.m., News. 12.10, Luncheon Concert. 1.40, Concert relayed from the Tuschinski Theatre, Amsterdam. 5.40, Time. 5.42, Orchestral Concert: March (Akker), Overture de concours (Akker), A Dutch Country-Wedding (Schouten), One-Step, Oh Boy! (Grit), Selection from The Beautiful Cuban Girl (Gabriel), Paraphrase, La Paloma (Yradier), Two Songs from Paganini (Lehar), The Clock is Striking (Glaauw), Medley (Thiele), Ich kenn ein andres Berlin (Benatzky), Waltz, Eva (Lehar), March, Old Comrades (Teike). 7.25, News. 7.40, Concert and Talk arranged by the Workers' Radio Society. 10.10, Concert relayed from the Royal Cinema, Amsterdam. 11.15 (approx.), Close Down.

HUIZEN (340.9 metres); 4 kW.—Transmits from 6.40 on 1,870 metres.—1.10, Concert of Trio Music. 6.10, Gramophone Selections. 8.25, Talk, followed by Concert, and "Le Vieux Joueur de Violon," Operetta (Offenbach).

JUAN-LES-PINS (Radio I.L.) (246 metres); 1.5 kW.—1.0, Symphony Concert: Lisbonna (Candiolo), Les vœux des cloches (Luigini), L'Enfant Prodigue (Debussy), Minuet (Moszkovsky), Romance in E Flat (Rubinstein), Air from Sadko (Rimsky-Korsakoff), The Count of Luxembourg (Lehar). 9.0, Concert, followed by News. 10.0, Dance Music. 10.30, Close Down.

KALUNDBORG (1,153 metres); 7 kW.—Programme also for Copenhagen (337 metres). 7.30 a.m., Physical Exercises. 11.0 a.m., Weather Report (Kalundborg only). 3.0, Concert: Russian March (Ganne); Waltz, Die Schönbrunner (Lanner); Fantasia on Schubert's Works (arr. Urbach); Fox-Trot, I've Got the Girl; Simple Aveu (Thomé); La Serenata (Tosti); Fox-Trot, Pierrette; Recitation, A petits pas (Sudessi); Marcietta (Sudessi); Waltz, Gold and Silver (Lehar); Selection from The Merry Widow (Lehar); Fox-Trot, Two Little Bluebirds; Waltz, Fascination (Marchetti); Melodies (Sjoberg); Fox-Trot, What Does It Matter? 6.20, A. P. Andersen, Talk: The Silk Industry in Denmark. 6.50, Weather Report (Kalundborg only). 7.0, News and Time. 7.20, Danish Programme Announcements for the Coming Week. 7.30, Talk: First Aid. 8.0, Chimes from the Town Hall. 8.2, Old Dance Music: MacMahon (Lumbye); Lagunen Waltz (Strauss); Petra Mazurka (Jensen); Hoch im Norden (Fährbach); Selection (Fährbach); The Toreador (Dahl); Polka, Euphrosyne (Lumbye); Sekstur (Lumbye); Eternelle ivresse (Ganne); Mazurka (Klinkwort); Salut Gallop (Lumbye); Last Night (Lumbye). 9.0, News, followed by Concert of Light Music: Comedy Overture (Keler-Bela); A Summer's Night (Waldteufel); Nyboder Polka (Jespersen); Pizzicato Gavotte for Strings (Borregaard); When the Salt is Spilt, Comedy (Gorner). 10.45, Dance Music. 12.0 Midnight, Chimes from the Town Hall. 12.15 a.m. (approx.) (Sunday), Close Down.

KATOWITZ (422 metres); 10 kW.—4.40, Notes on Economics. 5.0, Children's Programme. 6.0, Divine Service from Vilna. 6.45, Children's Letter Box. 7.10, Miscellaneous Announcements and News Items. 7.30, Talk and News. 8.15, Popular Concert. 10.0, Time and News. 10.30, Dance Music.

KAUNAS (2,000 metres); 7 kW.—12 Noon, Chimes. 7.0, Gramophone Selections. 9.15, Orchestral Concert: Overture to The Water Carrier (Cherubini), To Spring (Greig), Hungarian Dance No. 6 (Brahms), Russian Suite (Elukhin), Overture to Halka (Moniuszko), Minuet (Dvorak), Perceuse (Zarenfeld), Selection from Oberon (Weber).

LAHTI (1,525 metres); 35 kW.—5.0, Orchestral Concert, followed by Sports Notes. 8.0, Talk by M. Leo Pesonen. 8.20, Orchestral Concert. 8.45, News in Finnish and Swedish. 9.15, Programme from a Restaurant. 10.0, Close Down.

LANGENBERG (468.8 metres); 20 kW.—5.0, See Cologne. 5.30, English Lesson from Muenster (250 metres). 6.0, Concert from Elberfeld: Solinger Schützen-Marsch (v. Blon), Overture to Maritana (Wallace), Weaner Mad'In (Ziehrer), Selection from Aida (Verdi), Torch Dance (Krieger), Potpourri Wanderlieder (Manfred), Husaren-Fantare (Bohm

Programmes from Atroad.—

7.20, See Cologne. 7.45, Talk: The Westphalian Intellectual Circle, from Muenster. 8.15 to 1 a.m., see Cologne.

LEIPZIG (365.8 metres); 4 kW.—10 a.m., Cotton Prices and American Metal Report. 10.5 a.m., Weather Report and Announcements. 10.20 a.m., Programme Announcements. 10.25 a.m., "What the Post brings." 11.45 a.m., Weather Forecast in German and Esperanto, and Tide Report. 12 Noon, Musical Selections. 12.50, Wireless Notes. 12.55, Nauen Time Signal. 1.15, News and Exchange Quotations. 1.25, Wireless Notes. 3.0, Concert relayed from the *Jahresschan, Dresden* (276.2 metres). 4.0, Economics Notes, Market Prices, and Agricultural Report. 4.30, Symphony Concert. 6.0, See *Koenigswusterhausen*. 6.30, Wireless Talk. 6.45, Talk on Taxation. 7.0, Astronomy Talk. 7.30, Dr. Ulrich, Talk: Plant Life in the Ocean. 8.0, Weather and Time. 8.15, Concert of Popular Airs and Melodies. 10.0, News and Sports Notes. 10.30, Programme from *Voxhaus*. 12.30 a.m. (Sunday), Close Down.

LILLE, Call PTT (264 metres); 0.5 kW.—12.30, Concert: *Phédre* (Massenet), Two Italian Songs (Volpatti), *Valse de la Mandragore* (Cools), *Peer Gynt* (Grieg), *The Merry Widow* (Lehar), *Toledo* (Lherby). 1.35, Agricultural Report and Shipping Intelligence. 3.0, Mme. de Surgere, Talk: The Hygiene of Food. 7.0, Market Prices. 7.10, Concert arranged by l'Echo du Nord. 8.20, *Toto le Galeneux en vacances*: One-act Sketch (MM. Verschuren and Bauin). 8.30, Literary and Musical Programme, followed by News.

MADRID (Union Radio), Call EA7 (375 metres); 3 kW.—7.0, Orchestral Selections, *Circe* (Chapi), *La danse des libellules* (Lehar), *Una mujer indecisa* (Milan), Interlude by Luis Medina. 8.0, Dance Music. The following Programme relayed by *San Sebastian* (335 metres). 10.0, Time, followed by Concert, with *Ficardo Blanco* (Tenor), *The Alameda Quartet*, and the *Station Sextet*, News. 12 Midnight, Dance Music. 12.30 a.m., (Sunday) (approx.), Close Down.

MOTALA (1,380 metres); 30 kW.—Programme also for *Stockholm* (451.5 metres), *Goteborg* (416.5 metres), *Malmö* (260.9 metres), *Sundsvall* (545.6 metres), *Ostersund* (729 metres), and *Boden* (1,190 metres). 12.35, Weather Report. 12.45, Exchange Quotations. 12.55, Time Signal. 5.30, Children's Programme. 6.0, Talk: The Navy. 6.15, *Rolf's Cabaret Concert*. 7.30, Concert of Duets, followed by Light Musical Selections. 9.0, Talk on Topical Events. 9.15, News. 9.30, Weather. 9.45, Dance Music. 12.0 Midnight (approx.), Close Down.

NAPLES, Call INA (333.3 metres); 1.5 kW.—2.0 Exchange Quotations and News. 4.45, Weather Report and News. 4.50, Variety Selection. 4.53, Chamber of Commerce Notes and Exchange Quotations. 5.0, Concert: Orchestral Selections, (a) Spanish Waltz, *Adelante* (Tartini), (b) *Serenade, Petit Carmen* (Tarenghi), Soprano Solo, *Torto* (Tosti), Orchestral Selections, (a) *Intermezzo, Il giardino e le farfalle* (Angiolini), (b) *Oriental Dance* (Altvilla), Soprano Solo, *Almea* (Barbieri), Orchestral Selections, *The Merry Widow* (Lehar), Soprano Solo (Schumann), Orchestral Selections, (a) *Réverie* (Bazzini), (b) *Chant du ruisseau* (Billi), Soprano Solo, *La Juive* (Halévy), Orchestral Selections, (a) *Intermezzo, Profumata* (Bolognesi), (b) *Tarantella, Sorrento* (De Sena). 5.30, Time Signal. 5.35, Talk by R. Lotto. 8.20, Wireless Notes. 8.30, Government Notes. 8.40, Time Signal. 8.45, News. 8.48, Harbour Notes. 8.50, Concert of Neapolitan Melodies, *O marinariello* (Gambardella), *Ammore 'e femmena* (Nardella), *A Sirena Valente*, *Vuotate a cca, e vuotate a la* (de Chiara), *Suspiranno* (Nardella), *Oje Caruly* (Costa), *Cu gi cu gi a giaz* (Mazzone), *Santa Lucia luntana* (Mario), *Mum servo o rre* (Nardella), *La canzone del casinale* (Grillo), *Duet: O dentista* (Di Chiara), *Comme se canta a Napule* (Mario), *Cara piccina* (Lama), *Neoppa l'onne* (Passone), *Carmela* (de Curtis), *Mamma* (Feola), *Mandulinata a luna* (Nardella), *Palomma e notte* (Buongiovanni), *Canzona appassionata* (Mario), *Oje marena* (Costa), *Nun tuccammo stu tasto* (De Gregario), *Tarantela d'e vase* (Gambardella). 10.55, Calendar, Programme Announcements and Close Down.

OSLO (461.5 metres); 1.5 kW.—Programme relayed by *Hamar* on 555.6 metres, *Fredrikstad* (431.8 metres), *Porsgrund* (500 metres), *Notodden* (411 metres), and *Rjukan* (414 metres). 7.45, News, Agricultural Report and Time Signal. 8.2, Orchestral and Vocal Concert: *Intermezzo* from *Cavalleria Rusticana* (Mascagni), Selection from *The Hugenots* (Meyerbeer), Air from *Samson and Delilah* (Saint-Saëns), *Intermezzo* from *Il Voto* (Giordano). 8.30, Recital of English Songs: (a) *Drink Me Only*, (b) *Rose of My Heart* (Lohr), (c) *A Lane in Spain* (Li ambardo), (d) *Your Eyes Have Told*

Me So (O'Hara), (e) *Night and Day* (Lloyd), (f) *By the Light of the Jungle Moon* (Atkinson). 9.0, The Station Orchestra: *Hymn to the Sun* from Sadko (Rimsky-Korsakoff), *Romance* from *Mignon* (Thomas), *Ballet Music* from *Faust* (Gounod). 9.30, Weather, News Sports Notes and Talk on Topical Events. 10.0, Accordion Recital. 10.30, Dance Music. 12.0 Midnight (approx.), Close Down.

PARIS (Eiffel Tower), Call FL (2,650 metres); 5 kW.—6.45, *Le Journal Parlé* par T. S. F., read by its permanent contributors, including Talk by Maître *Durant-Farget: Chronique du Palais*. 8.10, Weather Report. 8.30, Vocal and Instrumental Concert: Quartet (Mozart), Selections from the Works of Professor A. Bournonville, accompanied by the Composer. 9.30, Educational Programme: Talks on Sociology—M. Dassoivre, Legislation; M. Michel Faquet, The Origin of Religions; M. Paul Perrin, Political Economy. 10.0 (approx.), Close Down.

PARIS (Petit Parisien) (349.9 metres); 0.5 kW.—8.45, Gramophone Selections, Talk, News and Announcements. 9.0, Concert: Overture to *Robert Bruce* (Rousseau); *Sylvia* (Delibes); Symphony Orchestra: (a) *Prelude to L'Après-midi d'un faune* (Debussy); (b) *Entr'actes* from *Pelleas and Mélisande* (Faure); Selection from *Mary Magdalene* (Massenet); *Serenade* (Widor); *Finale of A Summer Night in Madrid* (Glinka); News in the Intervals.

PARIS (Radio-Paris), Call CFR (1,750 metres); 6 kW.—12.30, Columbia Gramophone Recital: *Norwegian Dances* (Grieg); Music by the *Garde Republicaine, Dionysiaque* (Schmitt); *Melody, Le vieux Ruban*; *Aria* from *The Barber of Seville* (Rossini); *Cello Solo, Largo* (Handel); *Violin Solo, Mouvement perpetuel* (Rios); "Good News" by the *Singing Sophomores*; "Love News" by *Lepton and Johnstone*; *The Piccadilly Revels Band: Fox-Trot, Is She My Girl Friend?*; *Fox-Trot, Every Night I Bring*; *The Ipana Troubadours: Fox-Trot, Who's Wonderful?*; News. 1.50, Exchange Quotations and Religious News. 3.45, Dance Music; News. 7.30, Pianoforte Recital. 8.0, Agricultural Report. 8.15, Commander *Prevonnet*, Talk: Naval Events of the Week, followed by News. 8.30, Concert: Accordion Solo, (a) *Overture to Zampa* (Hérold); (b) *Serenade* (Till); *La Femme* (Grenet-Dancourt); *Le Renard et la Cigogne* (Rousseau); *La ronde du bois doré* (Cavillier); *Les trois oiseaux* (Delibes); Melodies, *Billy Arnold's Jazz*; News.

PITTSBURGH, Call KDKA (63 and 27 metres); 25 kW.—2.45, Telechron Time, News, Weather Report, Stock Quotations and Receipts of Principal Livestock Markets. 3.0, The Theatrical Calendar. 5.57, Time Signals. 6.0, Stock Quotations, Weather Report, Receipts of Principal Livestock Markets, Agricultural Notes and Market Prices. 8.25, Baseball Scores. 8.30, R.C.A. Demonstrative Hour, from WJZ Studio, New York. 9.30, Baseball Scores. 10.0, Telechron Time and Baseball Scores. 10.30, Baseball Scores. 11.0, Telechron Time and Baseball Scores. 11.25, The Theatrical Calendar and *Cambria Fair News*. 11.30, Selections by the *Vestinghouse Band*, from the *Palm Room* of the *William Penn Hotel*, Pittsburgh. 11.55, Baseball Scores. 12.0 Midnight, Telechron Time and Selections by the *Vestinghouse Band* continued. 1.0 a.m. (Sunday), Selections by the *United States Navy Band*, from the *WJZ Studio*, New York. 1.45, Talk by Dr. *Julius Klein*, from the *WJZ Studio*. 2.0 a.m., Programme and Longine Time from the *WJZ Studio*. 2.30 a.m., "The Keystone Duo with *Balladeers*." 4.0 a.m., Weather Report, Telechron Time and Baseball Scores. 4.15 a.m. (approx.), Close Down.

POSEN (344.8 metres); 1.5 kW.—7.0 a.m., Physical Exercises, by Mr. *Waxmann*. 1.0, Time Signal and Gramophone Selections. 2.0, Exchange Quotations and Agricultural Report. 2.15, News. 6.0, Concert by the *Café Esplanade Orchestra*. 7.0, Talk: *The Scouts*. 7.15, Elementary French Lesson by Mr. *Omer Neveux*. 7.35, Talk: *The Mission Fields*. 8.0, Report on Finance. 8.30, Concert by a *Mandoline Orchestra: Jeanne Dudiczowna* (Soprano), *Kajetan Kopczynski* (Baritone). 10.0, Time Signal, News, Weather Report, Announcements and Variety Selections. 10.40, Dance Music from the *Carlton Restaurant*. 12.0 Midnight, *Maison Philips' Concert*. 2.0 a.m. (approx.), (Sunday), Close Down.

PRAGUE (348.0 metres); 5 kW.—11.0 a.m., Gramophone Selections. 11.45 a.m., Agricultural Report. 12.0 Noon, Time Signal, News and Orchestral Music. 1.5, Industrial Notes. 1.20, Labour Exchange Notes. 1.35, Market Prices. 4.0, A Puppet Play. 5.0, Orchestral Concert. 6.0, German Transmission. 6.25, Agricultural Report. 6.55, Talk for Workers. 8.0, Operetta Concert (Seemann Bedrich). 10.0, Time Signal and News. 10.25, Programme from *Brunn*.

ROME, Call IRO (450 metres); 3 kW.—1.30, Opening Signal. 1.32, Trio Concert. 2.30, News and Close

Down. 4.40, Opening Signal and News. 4.50, Wireless Talk. 5.15, Agricultural Notes. 5.22, Time Signal. 5.30, Concert: *Pianoforte Solo, Fantasia and Fugue in G Minor* (Bach); *Tenor Solos*, (a) *Vaghissime sensibianze* (Donaudy); (b) *Martha* (Flotow); *Soprano Solos*, (a) *Visione* (Sgambati); (b) *Giroumetta* (Sibella); *Pianoforte Solo, Fantasia Op. 49* (Chopin); *Tenor Solos*, (a) *Il Tabarro* (Puccini); (b), *O dolce meraviglia* (Tosti); *Soprano Solos*, (a) *Pendant le bal* (Tchaikovsky); (b) *Serenade* (Gounod). 8.15, Opening Signal. Wireless Notes and Government Report. 8.35, Sports Notes, News, Exchange Quotations, Weather Report and Time Signal. 9.0, "Faust," Opera in Five Acts (Gounod); in the Interval, *Literary Talk* by *Lucie D'Ambra*. 11.5, News. 11.15 Close Down.

SCHENECTADY, Call 2XAD and 2XAF (21.96 and 31.4 metres); 30 kW.—11.45 a.m., Physical Exercises. 1.30, "Cheerio" Talk and Musical Selections. 4.15, Talk arranged by The Radio Household Institute, New York. 5.55, Time Signals. 6.0, Weather Report. 6.2, New York Stock Reports. 6.12, Weather Report. 11.25, Baseball Scores. 11.30, Concert. 12.25 a.m. (Sunday), Baseball Scores. 12.30 a.m., Programme by *Stalder's Pennsylvanians* from New York. 1.0 a.m., Selections by the "Bonnie Laddies" from New York. 1.30 a.m., Concert by *Philharmonic Orchestra*, relayed from the *Lewisohn Stadium*, New York. 3.20 a.m., Organ Recital by *Robert Berentsen*, from *Rochester*. 4.0 a.m., Dance Music from the *Hotel Ten Eyck*, Albany. 5.0 a.m., Close Down.

STAMBOUL (1,200 metres); 5 kW.—6.15, Concert of Turkish Music. 8.30, Weather and Time. 8.49, Concert: Spanish Symphony for Violin (Lalo); *The Entry of the Gods into Valhalla*, from *Rhiniegold* (Wagner). 10.0, News and Close Down.

STUTTGART (379.7 metres); 4 kW.—6.0, Talk on Beethoven, followed by Time, Weather and Sports Notes. 6.30, Programme from *Frankfurt*. 7.0, Talk: *Hermann Oeser*, relayed from *Freiburg* (577 metres). 7.30, Variety Concert from *Freiburg*, followed by Dance Music from *Café-Restaurant Wilhelmshaus*. 12.0 Midnight, Close Down.

TOULOUSE (Radiophonie du Midi) (391 metres); 3 kW.—12.30, Orchestral Concert. 8.39, Concert: *Ivresse d'amour, Dans la nuit tranquille, Dancing Tambourine, Silhouette, Pizzicato de concert, Clair de lune, Petite grand'mère, La carillon, Yesterday, My Blue Heaven, Bye, Bye, Blackbird, In a Little Spanish Town*. 9.0, Concert: *Mon regiment* (Goublier), *Overture to Patrie* (Bizet), *The Daughter of the Regiment* (Donizetti), *Song d'amour après le bal* (Czibulka), *Scènes provençales* (Cazeneuve), *Ballet Suite from Nymphes au bois* (Boyer), *Olle, yo sousis une espagnole* (Smet). 10.15, North African News. 10.30, Close Down.

VIENNA (577 and 517.2 metres); 1.5 and 5 kW.—6.15, Concert: Songs, (a) Air from *Der Freischütz* (Weber); (b) Air from *Martha* (Flotow); *Violin Solo, Zigeunerweisen* (Sarasate); Songs (Schubert), (a) *Marguerite at the Spinning Wheel*; (b) *Feuerlied*, (c) *Ungehduld*; Songs (Schumann and Brahms); *Pianoforte Solos*, (a) *Nocturne in F Sharp Major* (Chopin); (b) *Scherzo in F Sharp Minor* (Mendelssohn); (c) *Toccata* (Saint-Saëns). 7.15, Talk: *Mozart as Man and Artist*. 7.45, "Die goldene Meisterin," Operetta (Edmond Eysler), followed by Dance Music. 12.0 Midnight, Close Down.

VILNA (435 metres); 1.5 kW.—12.0 Noon, Programme from *Warsaw*. 5.0, News in Lithuanian. 5.15, News. 5.30, Agricultural Talk. 6.0, Divine Service from the *Ostra Brama Chapel*, Vilna. 6.50, Talk. 7.15, Gramophone Selections. 7.35, Literary Review. 8.0, News. 8.15, Programme from *Warsaw*. 10.30, Close Down.

WARSAW (1,111 metres); 10 kW.—12.0 Noon, Gramophone Selections. 1.0, Time, Chimes from the *Church of Notre Dame* at *Cracow*; *Aviation Notes* and *Weather*. 3.0, News, Weather and Agricultural Report. 5.0, Children's Programme relayed from *Cracow* (566 metres). 6.0, Divine Service from the *Ostra Brama Chapel*. 7.0, Miscellaneous. 7.35, Talk. 7.55, Agricultural Report. 8.5, News. 8.15, Popular Concert from the *Dolina Szwajcarska*; in the Interval, News in French. 10.0, Time, *Aviation Notes* and *Weather*. 10.5, News. 10.20, Police News and Sports Notes. 10.30, Dance Music, relayed from the *Oza Restaurant*, *Warsaw*. 11.30, Close Down.

ZURICH (588 metres); 1 kW.—12.30, Time and Weather. 12.32, Concert of Gramophone Selections. 12.50, News. 1.35, Weather, News and Exchange Quotations. 4.0, Concert from the *Carlton-Elbte Hotel*. 5.20, Concert of Accordion Selections. 5.55, Weather, Swiss Exchange Quotations, and Agricultural Report. 7.45, Time and Weather. 7.47, Dr. *Richard Huelsenbeck*, Talk: *Africa*. 8.15, Zither Recital. 8.30, Talk: *Women in Basle*. 9.20 (approx.), "The Answer." 10.0, Weather and News. 10.15, Close Down.

Sunday, July 8th.

All Times are reduced to British
Summer Time and are p.m. except
where otherwise stated.

Programmes from Abroad.—

BARCELONA (Radio Barcelona), Call EAJ1 (344.8 metres); 1.5 kW.—12.0 Noon, Chimes from the Barcelona Cathedral, Local Weather Report, Weather Forecast for Europe. 1.30, Iberia Instrumental Trio and Gramophone Record Selections. 2.45 to 9.0, Interval. 9.0, Sports Notes and Agricultural Market Prices. 9.15, Station Orchestra. 9.25, Talks, followed by Orchestral Selections. 10.0, Chimes from the Barcelona Cathedral, followed by Soprano and Tenor Song Recital from Operatic Works; Artists: Carmen C. Guitart and Miguel Artelli. 10.25, Station Orchestra. 11.0 (approx.), Close Down.

BASLE (1,000 metres); 1.5 kW.—8.30 (approx), Special Relay of the 1928 Song Festival from Lausanne. 10.15, News Bulletin and Weather Report. 10.30 (approx.), Close Down.

BERGEN (370.4 metres); 1.5 kW.—10.30 a.m., Divine Service relayed from the Cathedral. 12.30, Weather Forecast, News Bulletin, etc. 7.30 (approx.), Concert or Opera. 9.0, Talk, followed by Instrumental Music. 10.0, Weather Forecast, News Bulletin and Time Signal. 10.15, Dance Music Relay. 12.0 Midnight, Close Down.

BERLIN (Konigswusterhausen) (1,250 metres); 40 kW.—6.30 a.m., Early Morning Orchestral Concert relayed from Voxhaus. 9.0 a.m., Instrumental and Vocal Morning Recital relayed from Voxhaus. 11.30 a.m. Open Air Concert relayed from Voxhaus. 2.0, Children's Programme relayed from Voxhaus. 3.0, (approx.), Agricultural Programme relayed from Voxhaus. 6.30, Programme of Talks. 7.30 (approx.), Programme relayed from Voxhaus.

BERLIN (Voxhaus) (484 metres); 4 kW.—6.30 a.m. to 8.0 a.m., Early Morning Orchestral Concert. 9.0 a.m., Instrumental and Vocal Morning Recital followed by Chimes from the Berlin Cathedral. 11.30 to 12.50 a.m., Orchestral Concert. 3.0 to 3.55, Programme of Agricultural Talks, followed by Musical Selections. 7.0, Journalism Talk followed by Variety Concert. 10.30, Dance Music Programme. 12.30 a.m. (approx.) (Monday), Close Down.

BERN (411 metres); 1.5 kW.—1.0, Time Signal and Weather Forecast. 1.5, Orchestral Concert. 2.30, Agricultural Talk. 3.30, Orchestral Selections. 5.35 to 8.0, Interval. 8.0, Time Signal and Weather Forecast. 8.5, Programme of Talks. 8.30, Special relay of the Lausanne Song Festival for 1928 from Lausanne. 9.45, Sports Notes, News Bulletin, and Weather Report. 10.0, Concert of Orchestral Music. 10.35 (approx.), Close Down.

BRATISLAVA (300 metres); 1 kW.—9.30 a.m., Agricultural Report. 5.0, Sports Notes. 6.30, Agricultural Report, followed by Talk. 7.15, Programme relayed from Prague. 10.20, Programme relayed from Brunn.

BRESLAU (322.6 metres); 4 kW.—8.45 a.m., Relay of Chimes from Christ Church, Breslau. 11.0 a.m., Sacred Morning Recital. 12.0 Noon, Instrumental Concert. 2.0, Gardening Talk. 2.10, Agricultural Talk. 2.35, Chess Lesson by Adolf Kramer. 3.0, Children's Corner, Recital by Friedrich Reinecke. 3.30, Running Commentary on the Silesian Regatta from Breslau-Morgenuau. 5.15, Orchestral Concert. 6.30, Weather Forecast. 6.35, English Reading by Douglas Yates. 6.45, Programme of Talks. 8.30, Variety Concert. 10.0, News Bulletin. 10.30, Probable Relay of Dance Music from Berlin. 12.0 Midnight (approx.), Close Down.

BRUNN (441.2 metres); 3 kW.—12 Noon (approx.), Instrumental Concert. 4.0 (approx.), Variety Concert. 5.30, Transmission for Workers relayed from Prague. 6.0, German Transmission. 7.0, Instrumental Concert. 10.9, Time Signal and News Bulletin followed by Selections of Music. 11.0 (approx.), Close Down.

BRUSSELS (508.5 metres); 1.5 kW.—5.0 Relay of Dance Music. 6.0, Children's Corner with the Clowns; Bonzo and Sylvia in their Repertoire. 6.30, Musical Selections. 7.30, Le Radio-Chronique-Journal Parlé of Radio-Belgique, Programme of Short Topical Talks. 8.15, Instrumental Concert. 10.15, News Bulletin. 10.30 (approx.), Close Down.

BUDAPEST (555.6 metres); 35 kW.—9.0 a.m., News Bulletin. 10.0 a.m., Divine Service. 12.15, Time Signal, Weather Forecast and Musical Selections. 3.30, Agricultural Talk. 4.0, Children's Corner. 4.45, Time Signal and Weather Forecast. 5.0, Selections of Music. 6.30 (approx.), Talk and Sports Notes, followed by Dramatic Programme. 9.15, Time Signal and Sports Notes, followed by Musical Selections. 12.0 Midnight (approx.), Close Down.

COLOGNE (283 metres); 4kW.—Programme also for Langenberg (468.8 metres), Aix-la-Chapelle (400 metres), and Munster (250 metres). 9.0 to 10.0 a.m., Catholic Morning Recital. 11.0 (approx.), Talk, on "The Life and Works of Albrecht Dürer," by Fritz Worm. 12.25 to 12.55, Literary Programme. 2.30, Wireless Literature Talk by Arnold Stecker. 2.50, Chess Talk relayed from Düsseldorf. 5.30, Opéra-comique by Lortzing. 7.0 (approx.), Programme for Workers. 8.0, Programme relayed from Düsseldorf (See Langenberg Station) followed by News, Sports Notes, Concert and Dance Music. 12.0 Midnight (approx.), Close Down.

CORK, Call GCK (400 metres); 1.5 kW.—8.30 to 11.0, Concert by the Station Orchestra with Violin, Piano-forte and Vocal Solos and Michael O'Grada, Amhrain sa t-sean nos. 11.0 (approx.), Close Down.

CRACOW (566 metres); 1.5 kW.—10.15 a.m. to 11.55 a.m., Relay of Divine Service from a Church. 12.0 Noon, Fanfare from the Tower of the Church of Notre Dame in Cracow, Time Signal and Weather Forecast. 4.0, Agricultural Talk. 4.20, Report for Farmers, followed by the "Chronique Agricole," by Dr. St. Wasniewski. 5.0, Programme relayed from Warsaw. 6.30, Variety Selections. 6.45 (approx.), Programme of Talks and Readings. 8.0, Fanfare from the Church of Notre Dame, followed by Sports Notes. 8.30, Concert of Vocal Music by the Polish Wireless Choral Society under the Direction of Monsieur B. Wallek-Waleski, Soloists: Monsieur Stanislas Siwik (Singer), Monsieur Casimir Petecki (Piano-forte). The Sanctus and Benedictus from Schubert's Mass in A Major. 10.0, Programme relayed from Warsaw. 10.30, Orchestral Concert relayed from a Restaurant. 11.30 (approx.), Close Down.

DUBLIN, Call 2RN (319.1 metres); 1.5 kW.—8.30 to 11.0, Orchestral, Instrumental, Solo and Vocal Concert relayed from Cork. Violin Solos by Treasa Ni h-Ailpin. 11.0 (approx.), Close Down.

FRANKFURT (428.6 metres); 4 kW.—8.0 a.m., Vocal and Instrumental Morning Recital, followed by Talk for Parents. 6.0, Educational Talk arranged by the Rhein-Main Society for the Education of the People, followed by Concert and Dance Music relayed from Berlin. 12.30 a.m. (approx.) (Monday), Close Down.

HAMBURG, Call HA (in Morse) (394.7 metres); 4 kW.—Programme relayed by Hanover (297 metres), Bremen (272.7 metres), and Kiel (254.2 metres), 6.30 a.m., Early Morning Recital relayed from Voxhaus. 8.25 a.m., Time Signal. 8.30 a.m., Weather Report and News Bulletin. 8.50 a.m., Commerce Notes. 9.0 a.m., Programme Announcements. 9.15 a.m., Morning Recital. 11 a.m., Programme of Talks. 12.55, Nauen Time Signal. 1.0, Orchestral Concert. 3.0, Instrumental Concert. 5.0 (approx.), Programme of Talks and Musical Selections. 7.40, Sports Notes and Weather Forecast. 8.0, Instrumental Concert followed by News Bulletin and Concert from the Café Walthof. 11.0 (approx.), Close Down.

HILVERSUM (1,071 metres); 5 kW.—10.10 a.m. Divine Service relayed from a Church. 12.15 (approx.), Lunch-time Trio Concert. 2.40, Orchestral and Soloist Concert relayed from the Kurhaus in Scheveningen. The Residence Orchestra conducted by Ignaz Neumann. 4.40 (approx.), The Station Orchestra conducted by Nico Freep. 7.40, Time Signal, Weather Forecast and News Bulletin. 7.55 (approx.), Concert or Opera. 10.30 (approx.), Close Down.

HUIZEN (340.9 metres); Programme on 1,870 metres after 6.40 p.m.; 4 kW.—12.10, Concert by the Winkels Trio of Amsterdam. 1.10, Talk followed by Concert of Vocal and Instrumental Music. 7.10, Talks Programme followed by Concert or Play. 10.25, Choral Epilogue.

JUAN-LES-PINS (Radio LL) (246 metres); 1.5 kW.—1.0 to 2.0, Izar Orchestra relayed from the Juan-les-Pins Municipal Casino. Selections from Les Millions d'Arlequin (Drigo). 9.0 to 10.0, Concert and News Bulletin. 10.0, Dance Music by the Casino Dance Orchestra. 10.30 (approx.), Close Down.

KALUNDBORG (1,153 metres); 7 kW.—Programme also for Copenhagen (337 metres). 10.0 a.m., Divine Service Relay, Address. 11.30 to 11.40 a.m., Weather Report (for Kalundborg only). 2.0, Divine Service relayed from a Copenhagen Church. 4.0 to 5.30, Concert Relay. 6.50 to 7.0, Weather Report (for Kalundborg only). 7.0, News Bulletin. 7.15, Time Signal. 7.30, Talk. 8.0, Chimes relayed from the Copenhagen Town Hall. 8.2, Instrumental Concert. 9.30, (approx.) News Bulletin. 9.45, Orchestral Concert with Slavonic Fantasia for Cornet Solo (Höhne), Played by Christian Christensen. 10.45, Dance Music Programme. In the Interval at 12.0 Midnight, Chimes from the Copenhagen Town Hall. 12.30 a.m. (approx.) (Monday), Close Down.

KATOWITZ (422 metres); 10 kW.—10.15 a.m., Divine Service Relay. 12.0 Noon, Time Signal and News Bulletin. 4.0, Religious Address. 4.20, Talk: The Silesian Gardener, by W. Wlosik. 4.40, Technical Talk by Ing. Spiss. 5.0, Recital. 6.30, Various Announcements. 6.55, A Half Hour of Variety. 7.15, (approx.), Programme of Talks. 8.15, Concert relayed from Warsaw. 10.0, Time Signal and News Bulletin. 10.30, Programme of Dance Music. 11.30 (approx.), Close Down.

KAUNAS (2,000 metres); 7 kW.—12.0 Noon, Chimes. 12.5, Sacred Music. 12.30, Children's Corner. 5.0, Agricultural Programme. 6.0, Programme for Young People. 6.30, Sports Talk. 7.15, Selections of Music. 7.30, Health Talk. 8.30 (approx.), Time, Weather and News. 9.0, Concert.

KONIGSBERG (329.7 metres); 4 kW.—Programme relayed by Danzig on 272.7 metres. 9.0 a.m., Religious Address and Organ Music. 11.0 a.m., Weather Report (for Königsberg only). 11.15 a.m. (approx.), Orchestral and Vocal Concert. 12.55, Nauen Time Signal, Weather Report. 1.0, Carnival Relay from Allenstein. 4.0, Orchestral Concert. 6.20, Children's Corner. 7.0, Programme of Talks. 8.0, Variety Concert. 10.30 (approx.), News Bulletin and Sports Notes, followed by Dance Music Programme. 12.0 Midnight (approx.), Close Down.

LAHTI (1,525 metres); 35 kW.—Programme also for Helsingfors (375 metres). 8.0 a.m., Divine Service. 10.50 a.m., Instrumental Selections. 5.0, Programme of Talks and Music. 5.57, Time Signal, Weather Report and Press News. 6.10, Orchestral Concert directed by Erkki Linko. 7.20, Orchestral Concert, Danish and Swedish Songs and Dances followed by Finnish Melodies. 8.45, News in Finnish and Swedish. 9.15, Restaurant Concert Relay. 10.0 (approx.), Close Down.

LANGENBERG (468.8 metres); 20 kW.—Programme also for Aix-la-Chapelle (400 metres), Cologne (283 metres), and Munster (250 metres). 9.0 a.m., Programme from Cologne. 11.0 to 2.50 (approx.), Programme from Cologne. 2.50, Chess Talk from Düsseldorf, "Masters of the Rhine," by Dr. A. van Nuss. 5.30, Programme from Cologne. 7.0 (approx.), Programme for Workers. 8.0, Viennese Programme relayed from Düsseldorf, followed by Programme from Cologne. 12.0 Midnight (approx.), Close Down.

LAUSANNE (680 metres); 1.5 kW.—10.0 a.m., Divine Service relayed from the Victoria Hall in Geneva. 8.30, Special relay of the Lausanne Song Festival for 1928. 10.30 (approx.), Close Down.

LEIPZIG (365.8 metres); 4 kW.—8.30 a.m., Organ Recital relayed from the Leipzig University Church. 9.0 a.m., Vocal and Instrumental Concert. 11.0 a.m., Programme of Music and Talks. 1.0 to 3.0, Programme of Agricultural Talks. 3.0, Dresden Wireless Orchestra relayed from the Jahresschau in Dresden. 5.0, to 9.0, Programme of Talks and Music. 9.0, Bitte Einsteigen! Falstaff, Comedy in Three Acts by Franz Konrad Hoefert, Music by Verdi. 10.0, Sports Notes. 10.30, Dance Music Programme relayed from Berlin. 12.30 a.m. (approx.) (Monday), Close Down.

LILLE, Call PTT (264 metres); 0.5 kW.—12.30, Orchestral Concert organised by the Association de Radiophonie du Nord de la France under the Auspices of the Radio-Club de Lille. 1.35, Market Prices of Motor Oils, followed by Talks and Music. 7.30 (approx.) Orchestral Concert.

LYONS (Radio-Lyon) (291 metres); 1.5 kW.—11.0 a.m., Orchestral Concert. 11.30 a.m., Sacred Music. 7.30, First News Bulletin and Weather Forecast, followed by Sports Talk by M. Paul Garcin and Agricultural Report by M. Francillon Chazallet. 8.15, Instrumental Concert. 9.30, Orchestral Concert of Dance Music arranged by "La Maison Rabut." 10.30 (approx.), Close Down.

Programmes from Abroad.—

MADRID (Union Radio), Call EAJ7 (375 metres); 3 kW.—11.30 a.m., Municipal Band Concert conducted by Senor Villa, relayed from the Parque del Retiro, Madrid. 3.0, Hotel Nacional Orchestra. 3.30 to 7.0, Interval. 7.0, Children's Corner, Selections by Luis Medina. 8.0, Dance Music by the Artys Orchestra. 10.0, Chimes and Time Signal followed by Vocal and Instrumental Concert. 12.0, Midnight, Dance Music Programme. 12.30 a.m. (approx.) (Monday), Close Down.

MILAN (526.3 metres); 7 kW.—10.30 to 11.15 a.m. Vocal and Instrumental Concert of Religious Music. 12.30, Quartet Concert. 1.30 to 3.30, Interval. 3.30, Opening Signal followed by Quintet and Vocal Concert. 4.45, Children's Corner. 5.15, Dance Music from the Cova Restaurant. 6.15 to 8.25, Interval. 8.25, Opening Signal and Talks. 8.35, Time Signal and History Talk. 9.0, "Gianni Schicchi," Opera (Puccini); in the Intervals, Sports Notes and News. 11.45, (approx.), Close Down.

MOTALA (1,330 metres); 30 kW.—Programme also for Stockholm (461.5 metres), Göteborg (416.5 metres), Malmö (260.9 metres), and Sundsvall (545.6 metres).—Ostersund (720 metres), Boden (1,190 metres). 11.0 a.m., Divine Service relayed from a Church. 12.35, Weather Forecast, Stock Exchange Quotations, and Time Signal. 6.0, Divine Service relayed from the Betelkapellet: Address by the Pastor, the Rev. August Larsson. 7.0 (approx.), Concert or Play followed by Musical Selections: in the interval at 9.15, News and Weather. 11.0 (approx.), Close Down.

MUNICH (535.7 metres); 4 kW.—Programme relayed by Augsburg (536 metres), Kaiserlautern (204.4 metres) and Nuremberg (241.9 metres). 11.0 a.m., Chimes relayed from the Town Hall in Munich. 11.15 a.m., Weather Report. 11.30 a.m., Programme in honour of Count Zeppelin, Part I.: Talk on Count Zeppelin and his Creations, by Major Dr. Julius Ernst, followed by Concert. 1.5, Weather Report and News Bulletin. 1.10, Programme Announcements for the Day. 3.30, Zither Concert followed by Reading. 4.35, Tea-time Concert. 7.0, Local Sports Announcements. 7.30, Programme in Honour of Count Zeppelin, Part II.: Talk, My Memories of Count Zeppelin, by Achim von Winterfeld, followed by Various Announcements and News Bulletin. 10.30, Concert Relay. 12.0 Midnight (approx.), Close Down.

NAPLES, Call 1NA (333.3 metres); 1.5 kW.—10.0 a.m., Concert of Sacred Music. 4.45, Children's Corner. 5.0, Concert of Vocal and Instrumental Music. 5.30, Time Signal followed by Talks. 8.48, Report of the Harbour Authorities of Naples. 8.50, Vocal and Instrumental Concert, Selections from the Works of Mozart, Donizetti, Auber, Rossini, and Ricci. 10.55, Calendar and Programme Announcements. 11.0 (approx.), Close Down.

OSLO (461.5 metres); 1.5 kW.—Programme relayed by Hamar (555.6 metres), Porsgrund (590 metres), Fredriksstad (434.8 metres), Notodden (411 metres), and Riikan (448 metres). 10.20 a.m. (approx.), Chimes followed by Divine Service Relay. 7.15, Vocal and Instrumental Music. In the Intervals, News Bulletin, Weather Forecast and Talks. 10.30 (approx.), Dance Music relayed from the Hotel Bristol, Oslo. 12.0 Midnight (approx.), Close Down.

PARIS (Bole Supérieure), Call FPTT (453 metres); 0.5 kW.—Programme relayed at intervals by the following stations: Eiffel Tower (2,650 metres), Lyon PTT (476 metres), Marseilles (303 metres), Grenoble (416 metres), Toulouse PTT (290 metres), Bordeaux PTT (275 metres), Rennes (280 metres), Lille PTT (261 metres), and Limoges (285 metres). 8.0 a.m., News Bulletin and Time Signal. 10.25 a.m., International Time Signal, and Weather Forecast. 1.30, Orchestral Concert including Cavalleria Rusticana, Selection (Mascagni). 6.0, Le Radio Journal de France. 8.30, Astronomy Talk by M. Georges Morice. 8.45, Sports Notes. 9.0, Concert arranged by the Association Générale des Auditeurs de T.S.F. 11.0 (approx.), Close Down.

PARIS (Eiffel Tower), Call FL (2,650 metres); 5 kW.—8.56 a.m., Time Signal on 32.5 metres. 10.26 a.m., Time Signal on 2,650 metres. 6.45, Le Journal Parlé par T.S.F., read by its permanent contributors, Talks on Health, Police Anecdotes, Events in the World of Sport, etc., by Dr. Pierre Vachet, Detective Ashebé, MM. René Casalis, Marc Frayssinet, André Fournel, Jean Volvay, Mme. Paule Hellès and others. 8.10, Weather Forecast. 8.30, Concert by the Mario Cases Orchestra. 8.56, Time Signal on 32.5 metres. 11.26, Time Signal on 2,650 metres.

PARIS (Radio L.L.) (370 and 60 metres); 1 kW.—3.0, Concert of Dance Music arranged by Les Etablissements Radio L.L. 9.0, Instrumental and Vocal Concert. 10.30 (approx.), Close Down.

PARIS (Petit Parisien) (340.9 metres); 0.5 kW.—8.45, Gramophone Records followed by Talk and News Bulletin. 9.0, Orchestral Selections. 9.25, News Bulletin. 9.30, A Symphony Half-Hour under the direction of Professor Estyle of the Paris Conservatoire. 10.0, News Bulletin followed by Continuation of Symphony Concert, including March from "The Damnation of Faust" (Berlioz). 10.45 (approx.), Close Down.

PARIS (Radio-Paris), Call CFR (1,750 metres); 6 kW.—8.0 a.m., News Bulletin, Review of the Press. 12.0 Noon, Religious Address and Sacred Concert arranged by "La Vie Catholique," followed by Choral Recital of Religious Music, and News Bulletin. 12.45, Orchestral Concert by the Albert Locatelli Orchestra with Bilboquet in his Variety Repertoire. 4.30, Dance Music Programme by the Grand Vatel Orchestra, News in the Interval. 8.15, Agricultural Notes, General News Bulletin, and Press News. 8.30, Orchestral Concert: The Station Orchestra under the direction of M. Eugène Bigot. Selections from works of Trémisot, Glück, Debussy, Massenet, Saint-Saëns, and Duparc; News in the Interval. 10.45, Close Down.

PITTSBURGH, Call KDKA (62 and 27 metres); 25 kW.—3.45, Telechron Time Signal. 4.0, Divine Service Relay. 7.0, Romy's Stroll relayed from WJZ New York. 9.0, Telechron Time Signal and Instrumental Concert. 11.0, Telechron Time Signal followed by Baseball Scores. 11.30 (approx.), Little Symphony Orchestra. 12.0 Midnight, Telechron Time Signal followed by Programme of Music and Variety. 3.0 a.m., (Monday, approx.), Baseball Scores and Telechron Time Signal. 3.30 a.m., (approx.), Close Down.

POSEN (344.8 metres); 1.5 kW.—10.15 a.m., Divine Service Relay from the Basilica in Vilna. 12.0 Noon, Time, followed by Agricultural Report. 12.25, Talk for Farmers. 12.50, Various Announcements, followed by the Bulletin of the Polish League of Youth. 5.0, Concert relayed from Warsaw. 6.30, Children's Corner. 7.10, Talk by Mr. B. Busiakiewicz, Editor of "Tydzien Radjowy"; Sylva Kerum. 7.35, Talk relayed from Warsaw: Peoples of the Caucasus Mountains, by Prof. St. Poniatowski. 8.0, French Talk, "France," by Mr. Omer Neveux. 8.15, Evening Concert, Vocal Soloists: Monsieur Sigismund Jablonowski of Berlin (Baritone), Mademoiselle Maria Gasiarowska (Soprano), Professor Stanislaw Pawlak (Violinist), accompanied by Professor Francois Lukaszewicz. 10.0, Time Signal followed by Weather Forecast and Sports Notes. 10.20, Variety Items directed by Mr. J. Warnecki, of the Polish Theatre, Posen. 10.50, Dance Music Programme from the Palais Royal Restaurant. 12.0 Midnight (approx.), Close Down.

PRAGUE (344.8 metres); 5 kW.—9.0 a.m., Agricultural Report. 12.0 Noon, Military Band Concert. 1.5, Commerce and Trade Notes. 1.20, Various Announcements. 5.30, Transmission for Workers. 6.0, German Transmission. 7.0 (approx.), Variety Entertainment. 10.0, Time Signal and News Bulletin. 10.15 (approx.), Concert of Orchestral Music. 11.0 (approx.), Close Down.

ROME, Call IRO (450 metres); 3 kW.—10.15 to 11.0 a.m., Opening Signal followed by Sacred Concert of Vocal and Instrumental Music. 1.30 to 2.30, Concert by the Station Trio. 2.30 to 5.0, Interval. 5.0, Opening Signal. 5.2, Studio Concert. 6.0 to 6.30, Casinetta Dance Orchestra. 6.30 to 8.10, Interval. 8.10, Opening Signal followed by Talks. 8.30, Sports Notes, News Bulletin and Forestry Report. 8.58, Time Signal. 9.0, Instrumental Concert, Charpentier's Suite "Impressions d'Italie," with Fashion Talk in the interval by Madame Poupadour. 11.5, News Bulletin. 11.15 (approx.), Close Down.

SCHENECTADY, Call 2NAD and 2NAF (21.96 and 31.4 metres); 30 kW.—3.30, Protestant Divine Service from St. George's Episcopal Church, Schenectady. Address by the Rev. George F. Bambach, Rector. 10.30, Concert by the Ballad Singers, relayed from New York. 11.0, Stetson Parade, American Legion Band from Boston, Mass. 12.0 Midnight, Pianoforte Recital by Hands Barth, relayed from New York. 12.25 a.m. (Monday), Baseball Scores relayed from New York. 12.30 a.m., Capitol Theatre, Programme relayed from New York. 2.0 a.m., Political Talk: Our Government, by David Lawrence,

Editor of the "United States Daily," from Washington D.C. 2.15 a.m., Atwater Kent Programme relayed from New York. 2.45 a.m., Time Signal followed by Biblical Drama, relayed from New York. 3.15 a.m., Television Signals. 3.30 (approx.), Close Down.

STAMBOUL (1,200 metres); 5 kW.—4.30, Orchestral Concert. 5.30, Market Prices of Cereals. 6.15, Programme of Turkish Music. 8.15, Time Signal and Weather Forecast. 8.30 (approx.), Orchestral Concert. 10.0, News Bulletin of the Agence Anatolie. 10.30 (approx.), Close Down.

STETTIN (236 metres); 0.75 kW.—6.30 a.m. to 9.0 a.m., Instrumental and Vocal Music relayed from Voxhaus. 9.0 a.m., Sacred Morning Recital: Choral and Organ Music with Address. 11.30 a.m. to 12.0 Midnight, Programme of Talks, Concerts and Dance Music relayed from Voxhaus. 12.0 Midnight (approx.), Close Down.

STUTTGART (379.7 metres); 4 kW.—11.15 a.m., Vocal and Instrumental Morning Recital, followed by Musical Selections and Programme of Talks and Music. 2.0, Musical Programme for Children, followed by Concert. 6.0, Time Signal and Sports Notes, followed by Concert of Variety Items and Sketches; News at the end of the Concert.

TOULOUSE (Radiophonie du Midi) (391 metres); 3 kW.—10.20 a.m., Market Prices of Vegetables. 12.30, Orchestral Concert. 1.0, Carillon. 1.45, News Bulletin of the "Petit Parisien" and "La Dépêche." 2.0, Religious Address. 5.30, Exchange Quotations and News by the "Petit Marseillais," "L'Éclair" and "Le Petit Meridional" Newspapers. 5.40, Agricultural Report of the "Journal du Blé et du Vin," and the Confédération des Associations agricoles du Sud-Ouest. 8.0, Carillon, News by the Newspapers, "La Dépêche," "L'Express," "Le Midi," "Le Télégramme"; Exchange Quotations and Commerce Notes, followed by Motoring Notes. 8.30, Instrumental Concert: Selections from The Damnation of Faust (Gounod). 9.15, Instrumental and Accordion Concert, arranged by the "Association des Commerçants Radio-Électriciens du Midi." 10.15, North African News. 10.45 (approx.), Forthcoming Programme Announcements, Weather, News by the "Petit Parisien" and the Fourmier Agency. 11.30 (approx.), Close Down.

VIENNA (577 and 517.2 metres); 1.5 and 5 kW.—Programme relayed by Innsbruck (291.1 metres), Klagenfurt (272.7 metres) and Linz (251.2 metres).—10.30 a.m., Musical Selections. 11.0 a.m., Symphony Concert by the Vienna Symphony Orchestra. 4.0, Instrumental Concert, followed by Talks. 7.0 (approx.), Chamber Music Selections. 8.5, "The Star of Love," Comedy in Three Acts, by Sacha Guitry, translated into German by Otto Eisenschitz. 11.0 (approx.), Close Down.

VILNA (435 metres); 1.5 kW.—10.15 a.m., Divine Service, relayed from a Church. 1.0, Programme of News Bulletins and Talks, relayed from Warsaw, followed by Talks and Music. 7.25, Programme of Talks, followed by Programme relayed from Warsaw. News Bulletin and Dance Music. 11.30 (approx.), Close Down.

WARSAW (1,111 metres); 10 kW.—10.15 to 11.45 a.m., Divine Service Relay. 12.0 Noon, Time Signal. Fantare from the Tower of the Church of Notre Dame in Cracow, Aviation Report and Weather Forecast, 12.10 to 3.55, Interval. 3.55, Weather Forecast. 4.0 to 5.0, Programme of Agricultural Talks. 5.0, Vocal and Orchestral Concert, with Violin Solos from the Works of Paderewski. 6.30 to 6.50, Variety Items. 6.50, History Talk. 7.15 to 7.45, Interval. 7.45, Ethnography Talk on the Peoples of the Caucasus Mountains, by Professor St. Poniatowski. 8.15, Orchestral and Solo Concert. 10.0 to 10.30, Time Signal, Aviation Report, Weather Forecast, News, Police Report, Sports Notes. 10.30, Oaza Restaurant Dance Band, directed by W. Roszkowski and I. Karbowiak. 11.30 (approx.), Close Down.

ZAGREB (310 metres); 0.35 kW.—5.0, Orchestral Concert. 7.45 (approx.), Wireless Propaganda Talk. 8.0 (approx.), Musical Programme and News Bulletin. 11.15 (approx.), Close Down.

ZURICH (538 metres); 1 kW.—11.15 a.m., Concert by the Station Orchestra. 12.29, Weather Forecast. 12.30, Instrumental Concert. 8.0, Orchestral Request Programme with Baritone Solos from the Works of Hugo Wolf, by Hermann Achenbach. 10.0, Weather Forecast and News Bulletin. 10.15 (approx.), Close Down.

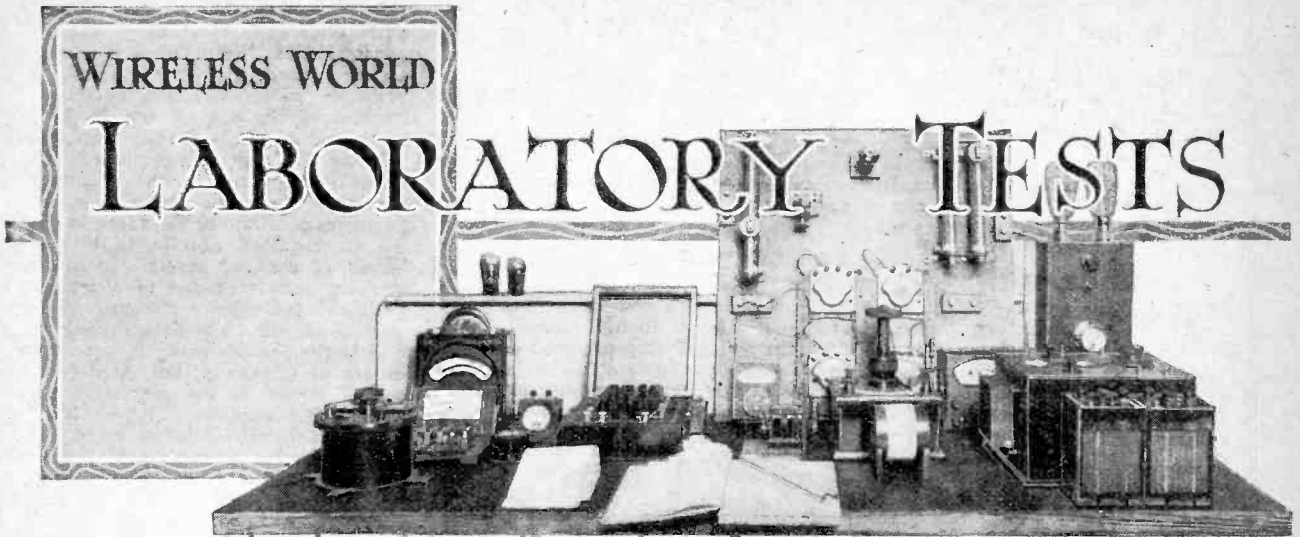

A Review of Manufacturers' Recent Products.

NEWAY "FOUR-POINT" CONDENSER.

The Neway condenser, though unconventional in appearance, has many advantages to offer over the ordinary type, not the least being its extraordinarily low minimum. In the condenser submitted for test this was found to be only 3.6 micro-mfds., the maximum being 0.000295 mfd. (nominal capacity 0.0003 mfd.).

Both sets of square vanes are pivoted and rotated by means of toothed sectors driven by a common pinion on the main spindle. The sectors are of moulded bakelite, and both sets of vanes are therefore insulated, a feature which renders the condenser adaptable to every type of circuit. Backlash in the gearing is effectively overcome by hairpin springs attached to each segment.

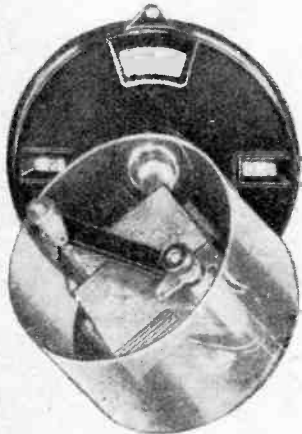

Neway "Four Point" condenser with celluloid dust cover.

The price of the 0.0003 mfd. condenser is 15s. and the 0.0005 mfd. 17s. 6d., and supplies are available from Messrs. Pett-

grew and Merriman (1925), Ltd., 2 and 5, Bucknall Street, London, W.C.2.

DAVEX ELIMINATOR.

In the Midland counties some difficulty is often expressed in tuning out 5GB when listening to other stations on

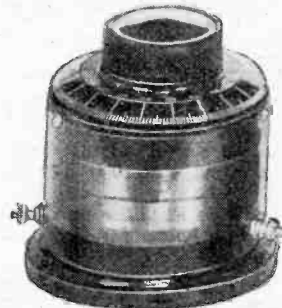

Davex eliminator for 5GB.

medium wavelengths, or even to 5XX on long waves. The Davex wave trap has been produced by the St. Mary's Motor Company, Market Harborough, with the object of eliminating interference from 5GB, and has proved itself entirely satisfactory in the Birmingham area. The unit consists of a cylindrical coil wound with enamelled wire and tuned to the 5GB wavelength by means of a compression type mica condenser. Three terminals are provided for connecting the eliminator in the aerial lead to the set; the third terminal includes only half the total turns in the aerial circuit and gives improved selectivity. The price of the unit is 10s.

DUBILIER ANTI-INTERFERENCE UNIT.

When it has been proved that noise from electrical machinery is being picked up on the aerial and is not due to in-

adequate screening of the receiver, the only remedy is to stop the interference at its source. This the Dubilier C.R.1 unit sets out to do. It consists of a system of smoothing condensers and resistances, and is applicable to both A.C. and D.C. motors and their switch gear. Five terminals are provided—one for connecting to the frame of the machine and the other two pairs for joining across the armature and brushes (in the case of D.C. motors) and the terminals of the starting rheostat. The unit is suitable for motors up to 240 volts D.C. and powers up to 1 kW., and is of substantial design. The moulded case measures 4½ in. x 4 in. x 2½ in., and the terminals and connections are protected by a circular moulded cover.



The Dubilier C.R.1 unit for reducing sparking interference caused by electric motors.

A test was made on a small ¾ h.p. 240-volt D.C. motor, and a marked decrease was observed in the noise picked

"Wireless World" Laboratory Tests.— up by a short-wave receiver working in an adjacent room. The improvement was more marked in the case of the commutator noise, but the sparking in the starter was also noticeably reduced. In any case, the starter noises occur only at wide intervals.

The price of the unit, which is made by the Dubilier Condenser Co. (1926), Ltd., Victoria Road, North Acton, London, W.3, is 30s.

OLDHAM H.T. UNITS.

In addition to the existing 2,500 mA hour type H.T. accumulators, Messrs. Oldham and Son, Ltd., Denton, Manchester, have now entered the market with a larger size (type L.H.T.L.), having a capacity of 5,500 milliampere-hours.

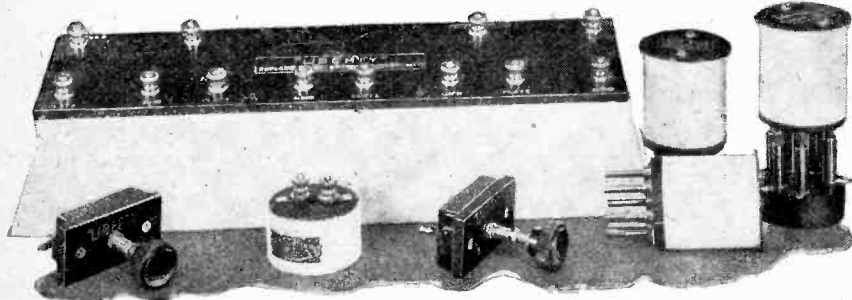

Intermediate amplifier unit and oscillator coils for the "Liberty" 8-valve Superhet, which now covers 10 to 3,000 metres.

The construction is interesting in that a separate glass container is used for each cell. Each 10-volt unit consists of five such cells, connected together with black sealing compound to form a solid block measuring 6 $\frac{1}{2}$ in. x 2 $\frac{1}{2}$ in. x 5 $\frac{1}{2}$ in. The connecting bridges between cells are burnt on to the plate lugs, and it is therefore

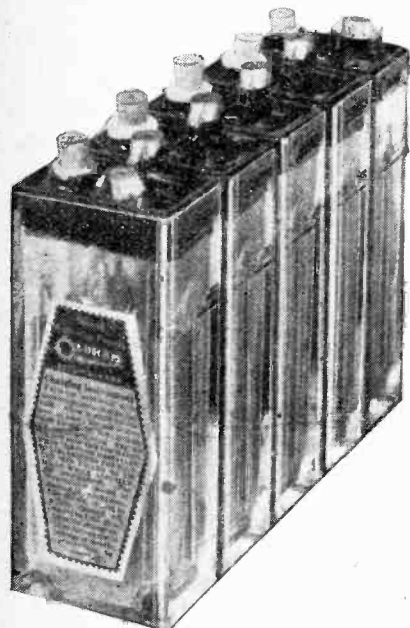

Oldham 10-volt H.T. unit; capacity 5,500 mA hours.

impracticable to separate the cells. The necessity for doing this does not exist, however, since each bridge piece is drilled to take wander plugs of standard diameter; the H.T. voltage can therefore be adjusted in steps of 2 volts. A pair of wander plugs with short connecting lead is supplied with each unit. The price of the new 10-volt unit is 8s., and carrying crates for 40 and 60-volt batteries are available at 6s. 4d. and 7s. respectively.

A NEW "LIBERTY" SUPERHET

The "Liberty" Supersonic units have been in production now for several years and have proved highly efficient, both from the point of view of signal strength and selectivity. A test report on one of the earlier types of unit was given in this journal on November 24th, 1926,

and even at that date remarkably good results were obtained.

The Radi-Arc Electrical Co., Ltd., Bennett Street, Chiswick, London, W.4, have always made the superheterodyne receiver one of their special studies, and the results of recent work is embodied in the latest set of units, which now cover a wave range of 10 to 3,000 metres. The price of the new kit, which includes the intermediate amplifier unit and oscillator coils with holder for 10-200, 250-800

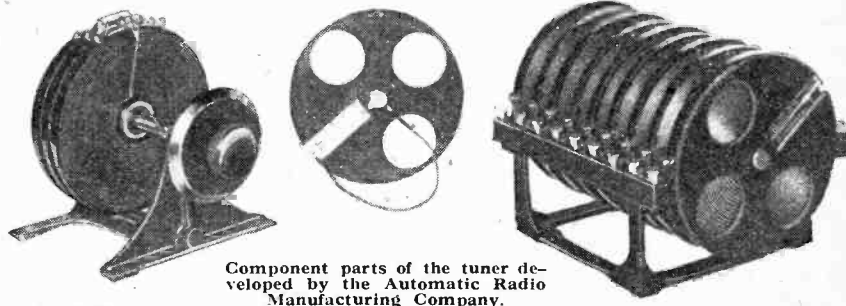

Component parts of the tuner developed by the Automatic Radio Manufacturing Company.

and 750-3,000 metres, is £5 10s. 6d. The blue prints supplied with the kit give details of additional parts required and the instructions are brief and to the point, so that the home constructor should have no difficulty in putting together the complete 8-valve receiver.

AUTOMATIC TUNER.

The "Tunometer," which was described in our sister journal, *Experi-*

mental Wireless, about two years ago (May, 1926), has now appeared in new guise under the auspices of the Automatic Radio Manufacturing Company, Gosford Road, Beccles, Suffolk. The principle of construction remains the same, and the makers are to be congratulated on the ingenuity displayed in winding the heavy gauge tinned wire in spiral grooves cut in the ebonite disc formers. By means of a new device known as a calibrator the turns in circuit can be adjusted exactly to the wavelength of each of several broadcasting stations, and by means of a system of switches individual stations can be selected at will. The device should work well in the country under favourable conditions of selectivity, but, as the fundamental circuit is the reacting detector with L.F. amplifiers, it is doubtful whether full use could be made of the station-selecting properties of the tuner when situated close to a broadcasting station.

TRADE NOTES.

Changes of Address.

Brandes, Ltd., to Cray Works, Sidcup, Kent, from Slough, Bucks.

London Electric Wire Co. and Smiths, Ltd. (sales, orders and accounts departments), to Church Road, Leyton, London, E.10 (Telephone: Walthamstow 2531), from Playhouse Yard.

CATALOGUES RECEIVED.

British Thomson-Houston Co., Ltd., Crown House, Aldwych, London, W.C.2. Illustrated leaflet of the R.K. loud speaker moving coil unit now being sold separately, price £9 10s.

A. H. Hunt, Ltd., Tunstall Road, Croydon. Illustrated 16-page catalogue

and price list of Helleesen dry cells and batteries.

Philips Lamps, Ltd., 145, Charing Cross Road, London, W.C.2. Illustrated leaflet of H.T. supply units for A.C. and D.C.

Dubilier Condenser Co. (1925), Ltd., Victoria Road, Acton, London, W.3. Illustrated folder with complete details for constructing the Treador III receiver.

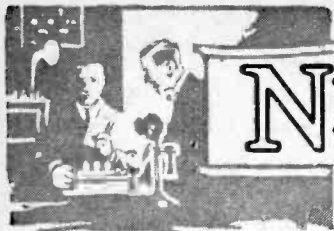

NEWS from the CLUBS



Secretaries of Local Clubs are invited to send in for publication club news of general interest. All photographs published will be paid for.

Portable Sets in Edinburgh Field Day.

On Saturday next, July 7th, members and friends of the Edinburgh and District Radio Society will meet in the grounds of Clermiston, Corstorphine, for open air tests with portable receivers.

Hon. Secretary: Mr. E. I. Robertson, 10, Richmond Terrace, Edinburgh.

○○○○

A Mystery Run.

In the near future, Slade Radio (Birmingham) will hold a "Mystery Run" and Field Day. Plans will be discussed at the Society's meeting on July 12th.

Hon. Secretary: Mr. H. Clews, 52, St. Thomas' Road, Erdington, Birmingham.

○○○○

Battery Resistance.

"Quality in Reproduction" was the subject of an interesting lecture demonstration given recently by Mr. F. D. Milner, GCFM, at the headquarters of the Tottenham Wireless Society, 10, Bruce Grove. To illustrate his remarks, Mr. Milner had a carefully designed three-valve receiver which was choke coupled to a moving coil loud speaker. A Tungar charger across the output terminals, of which a 6-volt accumulator was floated, supplied the field current. The receiver incorporated the anode feed system, and Mr. Milner showed how this successfully prevented low frequency oscillation.

The lecturer explained the causes of "motor-boating." This is primarily caused by a high resistance in the H.T. battery circuit. With modern sets, a considerable demand is made upon the source of H.T. Even with heavy duty H.T. dry batteries, the trouble is experienced, and also with poorly designed H.T. eliminators. Mr. Milner demonstrated the cause by inserting a high resistance in the middle of his bank of H.T. accumulators. "Motor-boating" was immediately heard in the speaker.

The meeting concluded with a demonstration of broadcast reception.

Hon. Secretary: Mr. F. E. R. Neale, 10, Bruce Grove, Tottenham, N.17.

○○○○

An Open Competition.

Recently the Golders Green and Hendon Radio Society, in conjunction with two groups from Muswell Hill Radio Society and the very valuable assistance of a field transmitter sent by Col. Vigers, O.B.E., M.C., commanding 47th Divisional Signal Company, held a most interesting direction-finding test in the neighbourhood of Rickmansworth.

The transmitter, consisting of an A Mark I* portable transmitter, was under the very able charge of Cpl. C. A. Webb. Its portability may

be judged by the fact that the station can be transmitting three minutes after arrival. Its weight is about 130lbs., and can, if necessary, be carried in packs by four men. The high tension supply of 1,000 volts is obtained from a Mackie generator run from a 6-volt accumulator. The vertical aerial is fixed into the ground by means of a bayonet. The reception by

On Sunday, July 15th, a novelty will be introduced by having a mobile transmitter, with semi-mobile receiving groups. Any member of any radio society is heartily welcome to send representatives of not more than three per group.

Full particulars of the scheme will be sent on application to the Hon. Secretary, Lt.-Col.



HUNTING A CONCEALED TRANSMITTER. Members of one of the direction-finding parties which endeavoured to locate a hidden transmitter in the Rickmansworth district on a recent field day organised by the Golders Green and Hendon Radio Society. A development of the same scheme is to be attempted on July 15th, when a mobile transmitter will be used.

groups which were located at a distance of about 11 miles from the station was found to be quite satisfactory. Operations commenced at 10.15; the winning group arrived at the transmitter at 3.20 and consisted of Mr. F. G. Ingleton, L. Hartley, F. C. Levy, all of the Muswell Hill Radio Society, followed only one minute later by Messrs. Zwanenbergh, Bird, and Aspen, of the Golders Green and Hendon Radio Society. The triangle of the former group was also better, and the first prize was, therefore, allotted to them. The third prize was given to Messrs. Bremner, Samson, and Roth. These were presented by Mrs. Handsley.

H. Ashley Ecarlett, D.S.O., 60, Paterson Road, N.W.2.

Prizes: — 1st, McMichael Super-Heterodyne Unit, value £6; 2nd, Value £2 2s.; and a third.

Judges, Lt.-Col. W. Vigers, O.B.E., M.C., Mr. H. S. Pocock, and one other. Tea will be arranged at the conclusion of the scheme.

○○○○

Attaché-Case Transmitter Tests.

The Southend and District Radio Society recently held the first field day of the season at Rochford, where the Society's transmitter was put into operation. Many well-known experimenters picked up the signals while a party of members equipped with a receiver heard the transmission on a loud-speaker. A small section of the party took an attaché-case transmitter and receiver to Wickford, working with the main station throughout the day.

Hon. Secretary: Mr. F. J. Waller, Eastwood House, Rochford, Essex.

FORTHCOMING EVENTS.

WEDNESDAY, JULY 4th.

North Middlesex Radio Society.—At 8 p.m. At St. Paul's Institute, Winchmore Hill. Lecture: "The Care of Accumulators," by Mr. L. F. Summers.

THURSDAY, JULY 5th.

Slade Radio (Birmingham).—At 8.15 p.m. At Headquarters. Talk on Moving Coil Loud Speakers by Mr. E. F. Handley.

SATURDAY, JULY 7th.

Edinburgh and District Radio Society.—Outing for members and friends at Clermiston, Corstorphine. (Meet at 3 p.m. at the Lodge Gate, top of Clermiston Road). Members with portable sets are requested to bring them.



HOUNSLOW CALLING. Members of the Hounslow Wireless Society photographed during a recent field day, when telephony transmission tests were carried out on Hounslow Heath.



RECENT INVENTIONS

The following abstracts are prepared, with the permission of the Comptroller of H.M. Stationery Office, from Specifications obtainable at the Patent Office, 25, Southampton Buildings, London W.C.2, price 1s. each.

Variable High Resistances (No. 284,770.)

Application date: November 3rd, 1926.
A flexible or telescopic tube B is mounted on a suitable baseboard between terminals T, T₁, the latter being

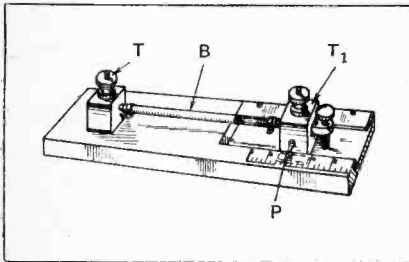

A variable resistance employing a liquid conductor. (No. 284,770.)

slidable and provided with an indicator or pointer P. The tube is preferably of rubber and filled with distilled water. As the tube is stretched lengthwise it contracts laterally, so that, assuming the volume of water remains constant within the range of operation, the resistance will vary as the square of the length of tube in circuit. The tube may be twisted or otherwise distorted, or a rigid telescopic

tube may be used, in which case a chamber is provided to accommodate any liquid displaced. A similar construction may be used in making low-resistance elements by substituting a suitable solution for the distilled water.

Patent issued to J. L. Baird and Television, Ltd.

Multiple-unit Valve Sets. (No. 274,901.)

Convention date (Germany): July 26th, 1926.

According to the inventor, the standard coupling-connections between valves of the ordinary three-electrode type cannot readily be adapted to multiple-unit valves of the well-known Loewe type. This is mainly due to the fact that the inter-stage couplings in the Loewe valves are mounted inside the bulb, and are therefore definitely fixed and invariable. The difficulty can, however, be overcome by inserting a small coupling condenser C between the grids of two multiple-unit stages as shown.

The figure illustrates a receiver comprising a two-stage H.F. amplifier connected to a three-stage tube enclosing a detector and two low-frequency amplifying stages. The condenser C acts as a kind of return coupling between the grid circuits of the two multiple-unit valves.

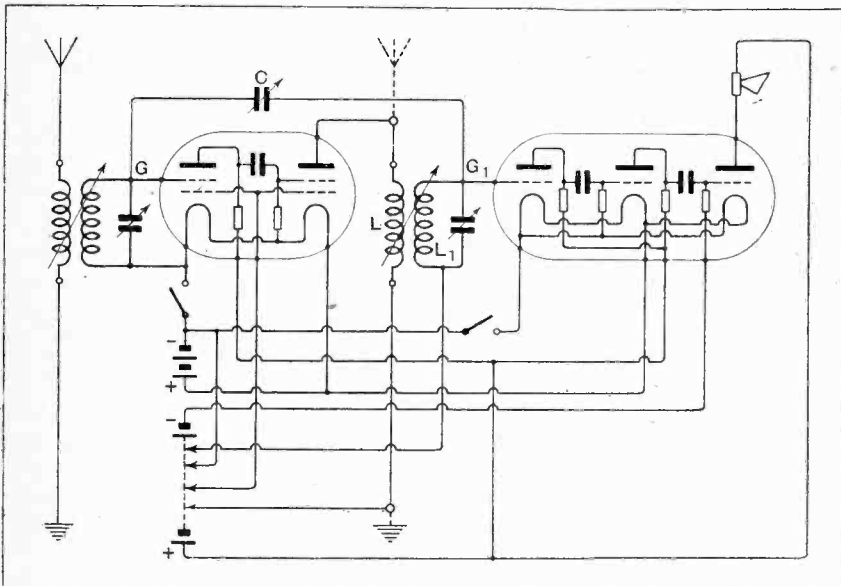

Method of creating coupling between Loewe multiple valves. (No. 274,901.)

The inductive coupling between the output coil L and the grid coil L₁ ensures that the fluctuations in voltage on the grid G₁ are carried back in correct phase to the grid G. The condenser C has a small value, and may conveniently consist of pieces of wire which are made to approach or recede from each other. Once the correct setting has been determined it may remain fixed once and for all. Patent issued to Dr. S. Loewe.

Battery Chargers. (No. 284,306.)

Convention date (Belgium): January 29th, 1927.

Relates to an arrangement whereby full-wave rectification can be utilised for a low charging voltage and half-wave rectification for a higher charging voltage. As shown in the figure, when the battery B is connected across the terminals P N rectified current corresponding to one half-wave of the supply will flow from the positive terminal P through the battery, and then through a variable resistance R and secondary coil S to the

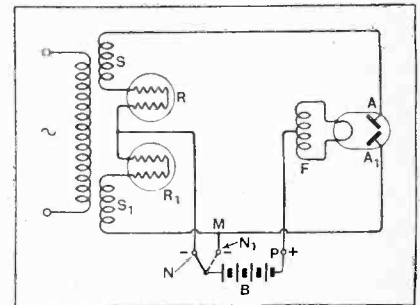

Battery charging scheme in which both high and low voltages can be obtained. (No. 284,306.)

anode A of the rectifier, and so back through the filament F to P. The next half-wave flows from P through the battery, then through variable resistance R₁ and coil S₁ to the anode A₁ of the rectifier, and back as before to the terminal P.

For a higher charging voltage the battery is connected across terminals P, N₁, and only alternate half-cycles of the supply are utilised, the circuit being from P through the battery, terminal N₁, junction point M, through coil S₁, resistances R₁ and R in series, coil S, anode A, and so back through the filament to the positive battery terminal.

Patent issued to the N. V. Phillips' Glowlamp Co.



News from All Quarters : By Our Special Correspondent.

Better Studios.—Is 5GB Experimental?—London's Regional Station.—An Auditions Problem.—Noisy Loud Speakers.—Entertainment or Education?

"Double-decker" Studios.

Even the most grudging critics are ready to agree that, in lighting upon the lounge of the Grand Hotel, Eastbourne, the B.B.C. engineers found a ready-made "studio" which was almost acoustically perfect. Since that happy choice they have found nothing to equal it, and no amount of draping or artificial echo effect at Savoy Hill has yielded results comparable with the transmissions from Eastbourne. Next winter, however, if my information is correct, the "Eastbourne effect" may again be secured by means of the "double-decker" studio.

Improved Acoustics.

The first of these studios will be erected at Manchester and will consist of a lower floor and a gallery. The performances will be given on the lower floor while the audience looks and listens from above. Not only will this arrangement give more floor space than is at present available to artists, but it will also furnish the advantage of a lofty ceiling and possibly a concave sound board.

Talks from the Scullery.

Manchester's example will undoubtedly be followed by other stations, and it is fairly certain that the London double-decker, which will probably follow next, will be provided with a domed roof.

It is worth mentioning, by the way, that further London studios will *not* be erected at Savoy Hill. The headquarters staff is beginning to suffer very badly from growing pains, and I shall not be surprised when the B.B.C. announces its intention to seek more commodious premises. Every corner of the present building has been utilised. One of the talks studios is a converted scullery!

The "Saveloy."

Talking of the scullery reminds me of the "Saveloy," a happy "house rag" which the B.B.C. staff have published (privately) for their own edification. Like most house organs, the "Saveloy" is of a rather intimate character, and many of its quips and sallies are lost

upon the rude outsider. The editor deserves congratulation for a delicious piece of foresight. He has omitted to give this first issue a date or a number; thereby he avoids committing himself in regard to future issues, if any!

Is 5GB Experimental?

The Savoy Hill post-bag is apparently a poor guide to the difference of opinion existing in various parts of the country

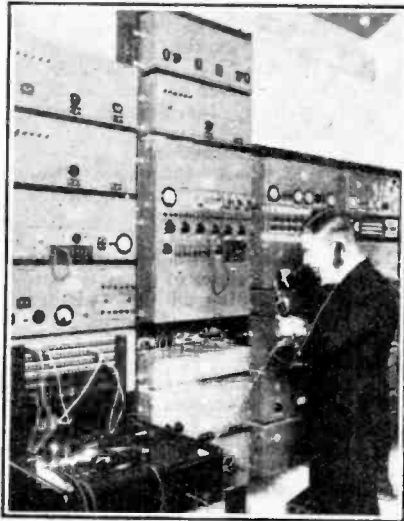

MUSIC BY BEAM. Mr. G. A. Mathieu testing the new Marconi-Mathieu "Multiplex" apparatus, whereby three or four telephonic and telegraphic messages can be dealt with simultaneously. During a recent demonstration at Bridgwater dance music was received at Montreal while the same aerials and apparatus were operating two Morse services.

over the performance of 5GB. "We have had practically no complaints for over two months," I was told by a B.B.C. official. "We regard this as a good sign," he added, "and the question has even arisen as to whether we should continue to describe 5GB as 'experimental.'"

Test Programmes.

The station will continue under the name "Davertry Experimental" for two reasons. The main reason is one that is probably overlooked by many listeners, viz., that the programmes from 5GB are as experimental as the apparatus.

For example, there are the Saturday night readings from the works of famous authors. This series succeeded a series of early evening dance programmes. The dance music was put on at the early hour simply to discover whether listeners approved of this style of entertainment at that particular time. Little enthusiasm was aroused, so the programme department decided on another experiment, i.e., the readings. I believe this item will shortly be dropped.

Experimental Apparatus.

The second reason why 5GB is still experimental is, of course, that the apparatus embodies the principle of low-power modulation and is not in duplicate, as in the other stations of the B.B.C.

The London Regional Station.

The B.B.C. Governors will soon be considering the tenders submitted for the construction of the station buildings at Brookman's Park. I understand that a remarkable divergence in price is revealed by some of the contractors' estimates. The usual reservation was included in the invitation for tenders, viz., that the Corporation did not bind itself to accept the lowest tender, but it is a safe prophecy that the work will go to a certain well-known firm whose tender was some thousands of pounds lower than that of its closest competitor.

Sweden Hears 2LO via America.

A listener in Vetlanda, Sweden, found himself in a sort of mental whirl the other evening, when he was attempting to pick up Stuttgart. The German station had announced its intention of relaying 2NAS, Schenectady, with the idea of getting details of the East to West Atlantic flight.

The Swedish listener thought he had tuned in Stuttgart, but was surprised to hear the announcement, "dance music from the Hotel Cecil, London." He verified his condenser settings. Yes, he was tuned in to Stuttgart.

Subsequently he discovered that Stuttgart had indeed been relaying Schenectady, but at the same time Schenectady had been relaying London!

A Lucky Musician.

The newspapers recently gave us the pathetic story of a broken musician, Mr. Kenneth Park, who, while playing his 'cello outside the Albert Hall, was patronised by no less a celebrity than the great Kreisler, who was about to give a performance in the Hall.

Now, I hear, the B.B.C. has given Mr. Park an audition, and it is likely that his name will shortly figure in the morning programme from 2LO and 5XX.

A Formidable Waiting List.

The number of auditions given at Savoy Hill has been recently growing at a rather alarming rate, with the result that on the waiting list there are now 200 prospective artists, all of whom have passed the audition test. How to find room in the programmes for all these performers is a serious problem.

Unfortunately few, if any, of these artists can be numbered in the "star" class; there is no waiting list for stars! What the Programme Department sighs for most is a few clever humorists.

Pity the Poor Passer-by.

Contrary to the traditional notion, quite a remarkable percentage of the community seem only too anxious to prove that it is more blessed to give than to receive. And since the advent of broadcasting, a new school has sprung into being which acts on the maxim that it is still more blessed if you can manage to receive and to give simultaneously.

These, of course, are the owners of loud speakers who place their instruments on the window-sill on summer evenings, presumably in the belief that the passer-by is dying for music, and would certainly be at home listening if his plaguey business did not take him out of doors.

Ear-stoppers or Head-holes?

A few days ago I heard the music of the Aldershot Tattoo all the way down a suburban street. When I left the effective zone of one loud speaker it was only to come under the benign influence of the next. This unsolicited entertainment continued for over a quarter of a mile.

Fortunately I had no aversion for the Aldershot music, but, if it had been otherwise, I wonder what remedy would have been available? Shall we find it necessary in a year or two to carry ear-stoppers or will municipalities provide small holes at intervals along the thoroughfares wherein, ostrich-like, we can thrust our heads and win momentary oblivion?

Entertainment v. Education.

There was little that scintillated in the conference held the other day by the B.B.C. and the British Institute of Adult Education, but a bright spot was undoubtedly afforded by a remark of Sir John Reith. "The primary responsibility of the B.E.C.," said Sir John, "is to entertain their *clientèle*. What-

FUTURE FEATURES.

London and Daventry.

JULY 8TH.—A Concert by the London Chamber Orchestra.

JULY 9TH.—Vaudeville Programme.

JULY 10TH.—A Military Band Concert.

JULY 11TH.—"The Daughter of the Regiment," a comic opera in two acts by Donizetti.

JULY 12TH.—Ulster Programme.

JULY 13TH.—"On with the Show of 1928," the Concert Party Entertainment.

JULY 14TH.—French Programme.

Daventry Experimental (5GB).

JULY 8TH.—A Band Concert.

JULY 9TH.—"The Daughter of the Regiment," a comic opera in two acts by Donizetti.

JULY 10TH.—A Symphony Concert. S.B. from Manchester.

JULY 11TH.—Ballad Concert.

JULY 12TH.—The "P.P. and P." Concert Party.

JULY 13TH.—"Carmen" (Act II) relayed from the Scala Theatre.

JULY 14TH.—Chamber Music.

Cardiff.

JULY 14TH.—"Recalled to Life," from a "Tale of Two Cities," played by the Station Radio Players.

Manchester.

JULY 13TH.—A Composite Programme from Sheffield, Leeds, Hull and Liverpool.

Newcastle.

JULY 10TH.—"Glimpses of the Past," a series of dramatic episodes dealing with the history of Newcastle and district.

Glasgow.

JULY 12TH.—"Stars," a play in one Act by Guy Rawlence.

Aberdeen.

JULY 10TH.—Scottish Variety Programme.

Belfast.

JULY 13TH.—"The Bailie's Nominee," a Scots Comedy in one act by David Martin.

JULY 14TH.—A Country Programme.

ever we do, therefore, with respect to education, must be subject to that claim."

This is surely one of the most invigorating expressions of the B.B.C. opinion that we have heard for many a long day. Those who wince at the notion of teaching by wireless will hail the "D.G.'s" remark with joy, and even those who seek to profit by the educational talks will, for the most part, agree that it is possible to have too much of a good thing.

De Groot this Evening.

De Groot will take part in 2LO's variety programme this evening (Wednesday).

Listeners will also hear Harry Graham giving some hints to lyric writers, while another feature of the programme will be the appearance of the Irish Players in "The Wooing of Julia Elizabeth," by James Stephens.

Three Days' Running Commentary on Balloon Race.

We in Britain have not yet enjoyed a running commentary on a balloon race, such as that staged by the American National Broadcasting Company on Saturday last, June 30th. The event was the International Balloon Race, starting from Detroit.

Special weather reports and news bulletins concerning the race were transmitted from the principal stations throughout the country. I understand that each balloon was equipped with a receiving set, so that the navigators were able, for the first time in balloon race history, to follow the progress of their rivals besides obtaining invaluable information regarding the weather ahead.

At the time of writing, it is stated that broadcast reports may continue until Monday, July 2nd, "if any of the balloons are still aloft." If this was done the running commentary must have been the longest in the history of broadcasting.

The Music of Spain.

Spanish items in the broadcasting programmes draw a singularly large number of appreciations. The works of De Falla, Granados and Albeniz being most popular. Another Spanish composer, poet, and critic, Pedro Morales, is visiting Savoy Hill on July 20 to conduct a programme of music of his country. The soloists are Brosa and Gertrude Johnson.

An "Atmospheric" Disturbance.

5GB listeners will have an "atmospheric disturbance" on July 11, set up by Harold Simpson. It is entitled "Something in the Air," and is the work of a well-known revue writer whose past contributions have included the "Nine o'clock Revue," the "Little Revue," and "Dover Street to Dixie."

"Three Months Hard" for Pirate.

The Soviet Government allows short shrift to transgressors under the wireless laws, according to a letter I have received from a correspondent in Holland. It appears that the maximum penalty for "clandestine listening" is three years' imprisonment.

The other day an unhappy young man in Petrograd was sentenced to three months' hard labour for listening without a licence, the leniency of his judges being due to his extreme youth. The authorities estimate that the number of "pirates" in Petrograd amounts to 15 per cent. of the total of listeners. After such a sentence, however, I imagine this number will rapidly decrease.

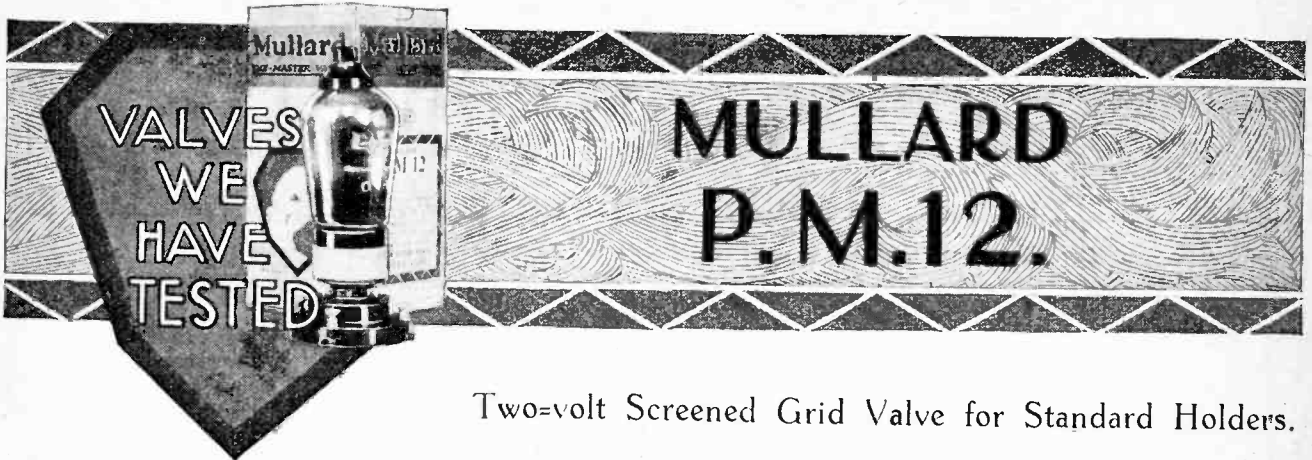

THE P.M. screened grid valve differs very little in appearance from the ordinary three-electrode valve, and the four-pin base fits into any standard valve holder. The bakelite-shrouded terminal on the top of the bulb is connected to the anode and the outer screen grid is joined to what would normally be the anode pin in the base. Filament and working grid connections are taken to the remaining three pins in the usual way.

The M-shaped filament F is carried on two independent supports, separated by a glass bead insulator. Surrounding the filament is the inner or working grid G which has a comparatively open mesh. The screen completely envelops the inner grid and filament and comprises a flanged metal base, a closely wound grid supported on four vertical corner wires, and a rectangular top plate. The anode consists of two flat plates electrically connected and mounted on each side of the screen grid. The anode assembly is supported on the flanged base of the screen, the insulation again consisting of glass beads.

The valve is well "gettered," and a mica disc is fitted to the top of the anode support for the purpose of throwing a shadow on the glass surrounding the top terminal when the magnesium is flashed; this is necessary in the interests of insulation. Very little magnesium gets below the flange of the screen grid, and its position is clearly defined. When mounting the valve its position should be adjusted until the partition between the two adjacent compartments of the screening box coincides with the flange.

Generally speaking the electrode construction is sufficiently robust for normal use, but care should be exercised, as it is probable that the anode could be slightly displaced by an accidental jar.

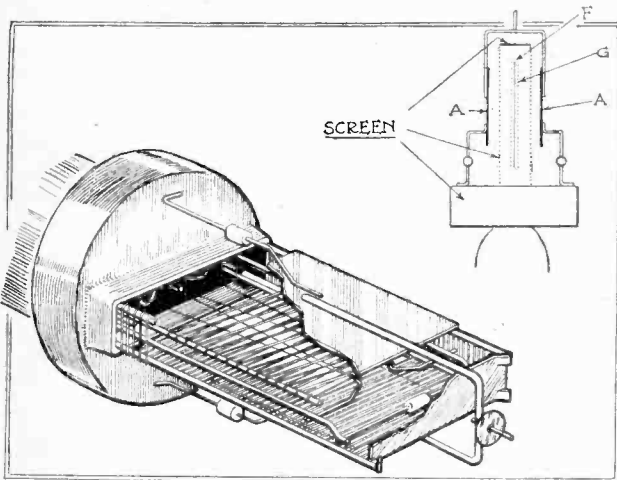

Electrode construction in the P.M.12.

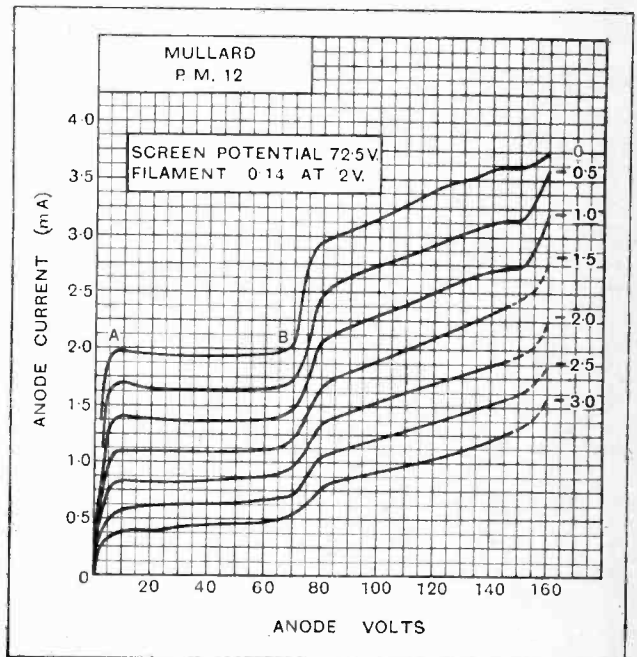

Average values between 80 and 140 volts H.T. A.C. resistance = 204,000 ohms, amplification factor = 85 mutual conductance = 0.42 mA/volt.

As is customary in the case of screened grid valves, the characteristics taken were of the anode volts, anode current variety, each curve representing a fixed value of grid bias. It is interesting to note that between A and B, where the slope is generally negative, the curves of the specimen tested are practically horizontal. For anode potentials between 10 and 60, therefore, the valve has practically infinite amplification factor and A.C. resistance. The correct working portion of the curve is, however, from 80 to 140 volts H.T., and over this range the average amplification factor and A.C. resistance work out at 85 and 204,000 ohms respectively. These figures are quite good, but the amplification factor of the particular valve in question is less than the maker's rating. The instruction slip gives the maximum anode voltage as 150, and on test we found that the anode current became erratic above this value.

An attempt was made to measure the residual anode-grid capacity by a direct method giving readings down to 0.5 micro-fd., but without result. It is reasonable to conclude, therefore, that the anode to grid capacity is less than this value.



The Editor does not hold himself responsible for the opinions of his correspondents.

Correspondence should be addressed to the Editor, "The Wireless World," Dorset House, Tudor Street, E.C.4, and must be accompanied by the writer's name and address.

THE "CONTROL" ROOM.

Sir,—May I express my hearty agreement with every word of Mr. G. B. Hargreaves' letter in the June 20th issue? Since we are assured by the highest B.B.C. authorities that the transmission is always perfect, and that it is only the miserable inefficiency of our receivers which is to blame, I have only one suggestion to offer.

It seems unfair that the genius who is responsible for this perfection should remain anonymous, since he does the major part of the work (as we know to our cost). I therefore suggest that the programmes should state, in addition to the name of the conductor, that of the "improver" so that we may know to whom we are indebted for the perfected renderings of the works produced.

M. H. ATKINSON.

Ewell, Surrey.
June 21st, 1928.

GRAMOPHONE PICK-UPS.

Sir,—With reference to Mr. Keylock's letter in your issue of June 20th, the following may be of interest.

The reproducer used by the H.M.V. Co. in the test they told me about was their present standard device for the ordinary gramophone; it was not their electrical pick-up. I am advised that neither the H.M.V. nor the Brunswick electrical pick-up is sold as a separate unit (this may not be correct).

I think Mr. Keylock's trouble must be that he has got an actually defective pick-up, since as far as reproduction is concerned I think I get better results from records than from wireless, or, at any rate, I get consistently good results from the former, whilst the latter varies a great deal and is on the average, I think, inferior.

That Mr. Keylock may have a defective pick-up is not improbable in the light of my limited experience with these devices. The following condensed history may be of interest and may encourage Mr. Keylock to try again.

PICK-UP MADE BY A. Co.—Chattered badly. Returned to makers, who said there was nothing wrong with it, kept it some time, and sent another one back. This was good but destroys records. Volume control fairly good.

PICK-UP MADE BY B. Co.—This had ideas of its own as to what notes should be heard, and suppressed those it did not approve of. We disagreed and parted company. No volume control supplied.

PICK-UP MADE BY C. Co.—This was an expensive instrument and was fairly good. No volume control supplied.

PICK-UP MADE BY D. Co.—This was the most extraordinary of all. There was a complete absence of low notes. Makers said that the instrument must have been damaged since leaving their works. Was in sealed carton when bought. Disposed of before writing makers, so I suggested, in view of their remark, that they sent me another against my deposit and if better than my present pick-up I would keep it. Did not reply to my letter. Volume control good.

PICK-UP MADE BY A. Co.—This was similar to the first one mentioned, and obtained for a friend. On loud passages it was fairly good, but the softer ones it left out altogether. A most curious effect. Makers said they never had complaints about their apparatus and could not understand it. Replaced with another pick-up, which was satisfactory. A new type of volume control was supplied with this: potentiometer arrangement, whereas the old type was a series resistance. For some obscure

reason the potentiometer arrangement proved a complete failure as an excessive amount of needle scratch came through when it was used. The control was altered to the series arrangement when the excessive scratch disappeared, though the control obtained was very poor. (Incidentally, the best volume control I have tried is the Clarostat.)

Now, in the light of the above experiences, I do not think Mr. Keylock should be discouraged. I think he will ultimately get a pick-up which will give decent reproduction, and he will then be able to enjoy his gramophone records *whilst they last*.

By the way, all the pick-ups mentioned were by well-known British makers, and none was a cheap imported article.

Wolverhampton.

C. H. S.

June 23rd, 1928.

THE EVERYMAN PORTABLE.

Sir,—Here, at approximately thirty miles from 5GB, and in the evening, I can run a small loud speaker off the *Wireless World* Everyman Portable using the frame only, and hear speech quite comfortably sitting about sixteen feet from the loud speaker.

A Ferranti A.F.4 transformer and a large size 4½-volt L.T. battery are the only alterations made, otherwise the set is the same as described.

It has travelled over three hundred miles at the bottom of



The Everyman Portable proves its capabilities. Our correspondent's letter describes its performance.

a sidecar and doesn't seem any the worse for the jolting it has received.

On the East Coast, about one hundred and twenty miles from Daventry, the tuning was much sharper, but 5GB still came in on the headphones using the frame, and by connecting up with thirty feet of H.T. wire for an aerial loud speaker strength was obtained.

The accompanying photograph illustrates the set in operation by the roadside.

Bedford.

June 21st, 1928.

F. WILSON.

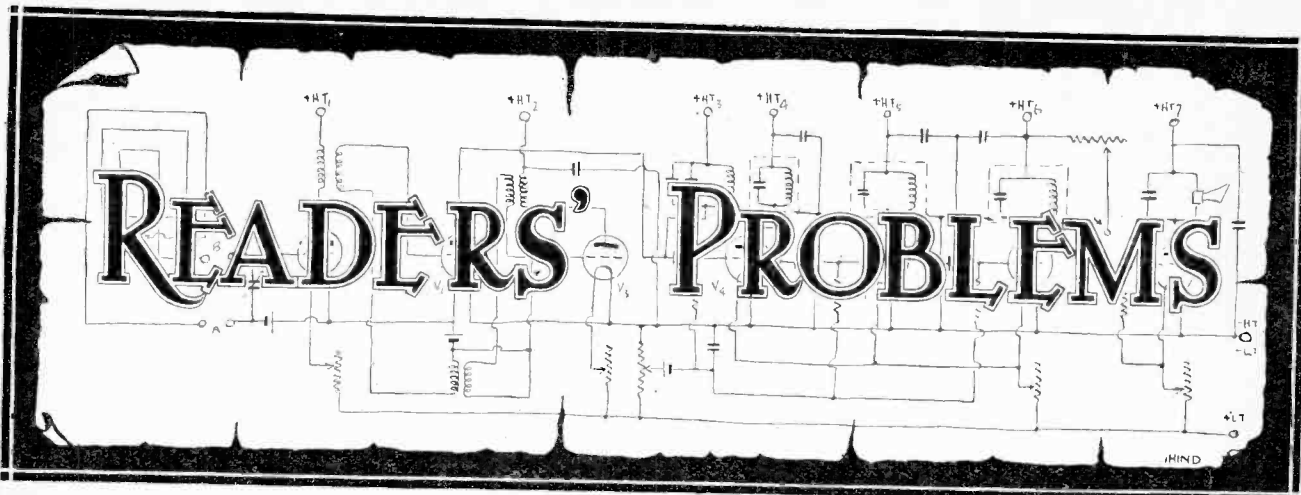

"The Wireless World" Supplies a Free Service of Technical Information.

The Service is subject to the rules of the Department, which are printed below; these must be strictly enforced, in the interests of readers themselves. A selection of queries of general interest is dealt with below, in some cases at greater length than would be possible in a letter.

Indoor Aerials.

As it is not possible for me to erect an outside aerial, I should be obliged for your advice as to the best indoor arrangement, bearing in mind the fact that I wish to receive distant stations.

E. H. S.

From time to time elaborate spiral and zig-zag indoor aerials are put forward, but it is more than doubtful that these confer any real benefit, and we doubt if you could do better than run three parallel wires, spaced by at least five feet if possible, under the ceiling of one of the upper rooms of your house, or in the loft, if possible. You may possibly be able to obtain a greater length by running the wires along an upper corridor or passageway. If possible, the conductors should be spaced from walls and ceilings. One end of each wire is left free, the other ends being joined together and connected to the down lead, which may be a single wire.

o o o o

Testing Connections.

Is there any simple and easy way of testing connections which are suspected of having developed a high resistance (without using expensive measuring instruments)? I ask this because I have come to the conclusion that the poor results I am obtaining are very probably due to a fault of this kind, and my receiver is so constructed that there is considerable difficulty in dismantling it.

P. G. W.

It is possible to check your connections for resistance with the help of an inexpensive ammeter reading up to some 1 or 2 amps, an L.T. battery, and a rheostat of 5 or 6 ohms. These should be set up in the circuit shown in Fig. 1, the test leads should be joined together, and the rheostat should be adjusted until a convenient reading of, say, 1 amp. is indicated on the meter. Now apply the test leads across the connection under sus-

picion, and if the reading shows an appreciable decrease you may assume that there is a fault.

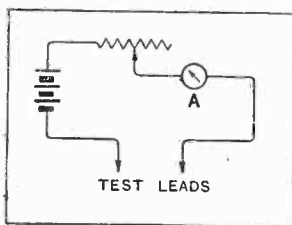

Fig. 1.—For locating imperfect joints; a simple testing circuit.

RULES.

- (1.) Only one question (which must deal with a single specific point) can be answered. Letters must be concisely worded and headed "Information Department."
- (2.) Queries must be written on one side of the paper, and diagrams drawn on a separate sheet. A self-addressed stamped envelope must be enclosed for postal reply.
- (3.) Designs or circuit diagrams for complete receivers cannot be given; under present-day conditions justice cannot be done to questions of this kind in the course of a letter.
- (4.) Practical wiring plans cannot be supplied or considered.
- (5.) Designs for components such as L.F. chokes, power transformers, etc. cannot be supplied.
- (6.) Queries arising from the construction or operation of receivers must be confined to constructional sets described in "The Wireless World" or to standard manufacturers' receivers.

Readers desiring information on matters beyond the scope of the Information Department are invited to submit suggestions regarding subjects to be treated in future articles or paragraphs.

A simple arrangement of this sort will indicate a resistance of an ohm or two quite clearly.

o o o o

Poor Reaction Control.

My detector L.F. receiver includes capacity-controlled reaction, which works quite satisfactorily on the normal broadcast waveband, but it is a failure as far as waves between 1,000 and 2,000 metres are concerned. At no part of the long-wave scale can control be called good, and at some wavelengths the receiver oscillates uncontrollably. Can you suggest any remedy?

H. R. D.

We suspect that choke resonance is responsible for your trouble, and would suggest that you should try the effect of connecting a high resistance of from 100,000 ohms to 250,000 across this component. You might also observe the effect of reducing the number of turns in your long-wave reaction coil, and also see if the connection of a second choke in series makes any improvement.

If none of our suggestions provide a complete cure, we think you would be well advised to try the throttle method of controlling reaction.

o o o o

An A.C. Valve Problem.

Is it permissible, in the construction of an A.C. valve receiver, to use the low-voltage winding of the power transformer to supply both the heating elements of the valves and also the filament of the rectifying valve which provides high tension?

J. R. R.

We do not care for this plan, and would recommend you not to adopt it. The filament of the H.T. rectifying valve will be at a high positive potential, and if your circuit is one in which the heater is connected to the cathode in any way, a short-circuit will be introduced across the H.T. supply.

A Coincidence.

I have recently abandoned a dry cell H.T. battery in favour of accumulators, and am surprised (and annoyed) to find that the receiver is not so selective as before. Would it improve matters if I were to put the battery in an earthed metal box? W. C. K.

We think it is purely a coincidence that the falling-off in selectivity of your receiver has become apparent after replacing the dry battery with accumulators; this change should have no effect as far as this quality is concerned.

At your distance from the nearest broadcasting station (we see it is about thirty miles) direct pick-up will be almost negligible, and in any case the increased bulk of the accumulator battery should make no difference, as it is at low-potential (from the "H.F." point of view).

A Quick Change-over.

In an H.F. amplifier with a screened grid valve, is it possible to change over the tuned anode coils by means of a double-pole double-throw switch in such a way that the coil not required is automatically short-circuited? If so, will you please give me the connections? C. M.

The switching arrangement you require can certainly be performed with a D.P.D.T. switch in the manner shown in Fig. 2, from which you will see that one

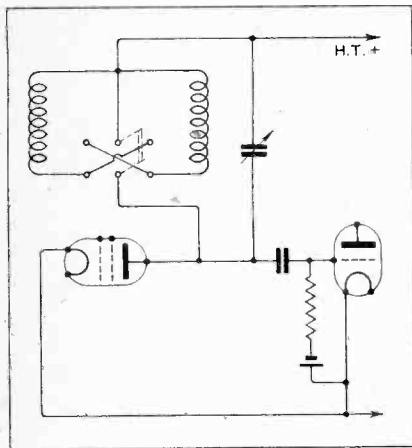

Fig. 2.—Connections of a switch for changing tuned anode coils. The idle winding is short-circuited.

blade of the switch changes over the H.F. valve anode connection to the coil required, while the other blade short-circuits the idle coil.

The "New All-Wave Four."

I am thinking of modifying my original "All-Wave Four" receiver to conform with the new arrangement. Would it be necessary to rewind the H.F. transformers? C. R. L.

No, the original coils would do quite well; indeed, there is little to choose between them in point of efficiency, particularly as regards the short-wave

coupling, although the later designs are mechanically more robust.

A Corrected L.F. Amplifier.

My A.C. valve receiver, on the lines of that described in "The Wireless World" for March 21st, is more than satisfactory for distant reception, but quality on my local transmission is disappointing; I should describe it as "thin" and lacking in the lower tones. The station is less than four miles away, and, to reduce signals sufficiently, it is necessary to detune the circuits. Can you tell me the probable cause of my trouble? P. R. W.

It must be realised that the receiver in question comprises a "corrected" L.F. stage, arranged to compensate for the attenuation of the higher audible frequencies which inevitably takes place in an efficient H.F. amplifier. By operating the set in a detuned condition, you are, in effect, removing this attenuation, and the L.F. amplifier will not provide sufficient amplification of the lower frequencies. In other words, correction is no longer required. We suggest that you should try the set with a very short indoor aerial, and check the correctness of our diagnosis by listening to the tuning note as at present transmitted by B.B.C. stations; the pitch will probably be lowered very noticeably when the two circuits are brought into exact tune.

Anno Domini?

I find that my receiver, which would originally oscillate with the reaction and aerial coils making an angle of about 45 degrees, is now quite insensitive until the coupling is increased to maximum. Can you suggest a reason for this? The general performance of the set seems to have fallen off very considerably. T. H.

The effect you describe might be attributable to a number of causes, but we suggest the most likely one is a run-down H.T. battery, or possible loss of emission of the detector valve filament. In cases of this kind we can do little but suggest point to point tests, following a check of the battery voltages.

A Palliative.

My neutralised receiver gave a good deal of trouble on account of H.F. instability until I accidentally discovered that this fault was cured by omitting the single bias cell connected to the first valve, and joining together the leads. The receiver now appears to be working well; do you think that it is satisfactory to operate it in this manner? N. S. M.

It seems that such stability as you have now attained is partly due to damping by grid current in the H.F. valve. We ourselves would not rest satisfied with such an arrangement, and think you would be well advised to look to the construction of your H.F. transformer, paying particular attention to the neutralising winding and the connections to it. You should also assure yourself that the relative posi-

tions of the coils are as specified in the design you have followed, and that the screening is adequate.

Frame Aerial Switching.

I am constructing a three-section frame aerial, and wish to place the separate windings in series or parallel for long or short wave reception. Will you show me how this may be done, bearing in mind the fact that I wish to keep the centre tapping symmetrical on both ranges. D. R. S.

The connections you require are given in Fig. 3. A four-pole change-over switch will be required; this should be of a type

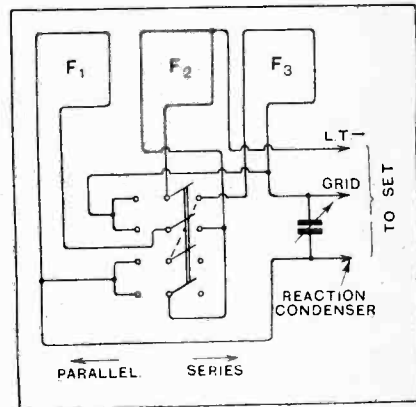

Fig. 3.—Sectionally wound frame aerial with series-parallel switching and centre tap.

in which the insulation has good dielectric properties, and with a reasonably low self-capacity.

Testing an L.F. Transformer.

The windings of my L.F. transformer seem to be continuous when tested by the "phones-and-battery" method, but I am inclined to think in spite of this that a partial failure is responsible for intermittent crackling noises in my loud speaker. Will you tell me how a more conclusive test may be made? C. S. G.

If there is an intermittent connection in your transformer, it will probably be found in the primary winding, and to test this we suggest that this should be left in position in the anode circuit of the valve, while a pair of telephones should be joined to the secondary terminals after removing the original connections. The remaining valves in the set should be withdrawn and the aerial disconnected. Now listen carefully, and if there are any crackling noises audible in the phones, it is probable that the transformer is at fault. Several valves should be tried, and you should assure yourself that there is no faulty or doubtful connection.

You can make a further check by joining the phones and a battery in series across each winding in turn, listening carefully for some minutes, although it should be pointed out that intermittency of the kind sometimes encountered in transformer windings is dependent to a certain extent on the applied voltage.

The Wireless World

AND
RADIO REVIEW
(16th Year of Publication)

No. 463.

WEDNESDAY, JULY 11TH, 1928

VOL. XXIII, No. 2.

Editor: HUGH S. POCOCK.

Assistant Editor: F. H. HAYNES.

Editorial Offices: 116-117, FLEET STREET, LONDON, E.C.4.

Editorial Telephone: City 9472 (5 lines)

Advertising and Publishing Offices:

DORSET HOUSE, TUDOR STREET, LONDON, E.C.4.

Telephone: City 2847 (13 lines). Telegrams: "Ethiaworld, Fleet, London."

COVENTRY Hertford Street.

Telegrams "Cyclist, Coventry." Telephone 6210 Coventry.

BIRMINGHAM: Guildhall Buildings, Navigation Street.

Telegrams "Autopress, Birmingham." Telephones 2970 and 2971 Midland.

MANCHESTER 260, Deansgate.

Telegrams "Hife, Manchester." Telephone 8970 City (4 lines).

Subscription Rates: Home, 17s. 4d.; Canada, 17s. 4d.; other countries abroad, 19s. 6d. per annum.

As many of the circuits and apparatus described in these pages are covered by patents, readers are advised, before making use of them, to satisfy themselves that they would not be infringing patents.

CONTENTS OF THIS ISSUE.

	PAGE
EDITORIAL	29
THE OUTPUT STAGE AND THE PENTODE. BY N. W. McLACHLAN, D.Sc., M.I.E.E.	30
SWITCH-OVER THREE (CONCLUDED). BY H. F. SMITH	34
USEFUL DATA CHARTS. BY R. T. BEATTY, M.A., B.E., D.Sc.	38
SIGNAL MEASUREMENTS. BY "RADIOPHARE"	40
NEW APPARATUS	41
CURRENT TOPICS	43
PROGRAMMES FROM ABROAD	45
AT THE SCIENCE MUSEUM. BY R. P. G. DENSMAN, M.A., A.M.I.E.E.	49
BROADCAST BREVITIES	54
LETTERS TO THE EDITOR	56
READERS' PROBLEMS	58

AN ELECTRICITY SUPPLY RAMP.

A FEW days ago we received from the Secretary of the Institution of Electrical Engineers a copy of the regulations in regard to radio apparatus connected to electric supply mains, which have just been issued by that body in the form of a supplement to the Ninth Edition of the Institution's Regulations for the Electrical Equipment of Buildings.

These Regulations, we are told, have been prepared by a Sub-Committee on which the Radio Manufacturers' Association and other interested bodies were represented.

Another Notice to Consumers.

Almost at the same time we receive from a reader a copy of a circular notice issued by the Westminster Electric Supply Corporation, Ltd., informing its consumers that "no authorisation has been given for the use of its lighting or power circuits in connection with wireless sets.

"In the event of the Corporation desiring to change the supply to any premises from direct current to alter-

nating current, it will not pay the cost of making any necessary changes to wireless sets so connected."

In our issue of April 18th, in referring to the subject of mains units and electric supply, we commented on the action of the Bangor (North Wales) Electric Supply Corporation, which had made a decision to the same effect, and we said that it seemed to us that the Bangor Corporation had decided on the pursuit of a policy which it had no legal authority to enforce. On enquiry of the Electricity Commission, it was explained to us then that it is customary for a supply company to make good any such changes in consumers' electrical equipment as may be rendered necessary with a change in the nature of the supply.

An Ordinary Domestic Use.

We feel that users of mains units for wireless receivers are entitled to ask by what authority electric supply corporations are issuing such notices to consumers. As we understand it, an electric supply corporation is not entitled to pick and choose between its consumers, and is under an obligation to give a satisfactory service, and supply electricity for all ordinary domestic purposes. The use of the mains for supplying wireless sets has now become quite definitely an ordinary domestic purpose. There are thousands of such equipments already installed, and their manufacture forms quite an important section of the wireless industry. The Institution of Electrical Engineers has, as we see, gone to the trouble of drawing up special regulations to guide manufacturers in the precautions and general regulations which they think it necessary to recommend for the design of such sets and their installation.

Is it a Ramp?

How, then, in the face of all this, can an electric supply corporation adopt the ridiculous attitude of suggesting that their authority is necessary before such installations shall be connected to their supply mains? It would seem to us that it is little less than a ramp on their part in the endeavour to slide out of the obligations to which they would be put if the supply is changed from D.C. to A.C. We have the opinion of the Electricity Commission to support us in our belief that it not a question of choice, but of obligation, for electricity supply corporations to replace or make what alterations are necessary to electrical apparatus used by the consumer if the corporation decides to change over from direct to alternating current, provided, of course, that prompt notice is given to the corporation by the consumer as to what apparatus he has in use as soon as notice that a change is likely to come about is given him by the supply company.



The OUTPUT STAGE and the PENTODE

The Principles Underlying the Use of a High Resistance Pentode Valve in the Output Stage (Part 1).

By N. W. McLACHLAN,
D.Sc., M.I.E.E.

Will the pentode replace its three-electrode predecessors as a loud speaker valve? Although this new valve will not be available for embodying in receiver design for about two months, its merits are arousing a widespread interest.

An article in last week's issue briefly explained its principles, and the present article clearly shows its possible advantages when used as an output stage amplifier.

AS its name implies, the pentode is a thermionic device associated with the number "five." The object under consideration is a valve with five electrodes, illustrated in this article. Its main purpose in life is to provide us with a power valve capable of relatively large output, when the voltage on the grid is relatively small. In other words, it is a valve whose magnification factor is large, and whose anode current is copious. Readers are now familiar with the tetrode, or screened grid valve—at least, they ought to be by this time—which is to all intents and purposes a triode having an electrostatic screen between the control grid and the anode. This valve has a magnification factor, $m=200$, and an internal resistance, $\rho=250,000$ ohms. The normal anode current is from 1 to 2 mA., and the permissible grid swing about half a volt. Viewed in the light of present-day practice, this tetrode is useless as a power valve, because it is not customary to build loud speakers to work from currents of only 1 mA. Now, I have always contended in this journal that the power valve should be of fairly low internal resistance—say 2,500 to 4,000 ohms. Since the pentode has an internal resistance of 30,000 ohms or more, the reader will say, "Ah! there you are—just like the Vicar of Bray, preaching and singing to suit the changing times!" But I am not to be caught so easily as that. Moreover, it behoves me to explain the altered circumstances.

Greater Output than the Triode.

In the first place, contemporary loud speakers require a good many milliamperes to operate them properly. To secure this condition, the steady anode feed to the valve must be 15 mA. or upwards. Also, it must be possible for the signal to vary the current substantially from 15 to 3 and 15 to 27—i.e., 12 mA. each way. What type of triode fulfils this condition? The answer is, of course, a triode of low internal resistance. If you don't believe this, consult the makers' characteristic curves.

In the second place, it is a fact, owing to physical limitations in valve design, that a triode of low internal

resistance has a small magnification factor. Thus, when using the triode as a power valve, we are faced with a condition where low internal resistance is accompanied by low amplification factor. In the pentode the feed current is comparatively large. For a given signal voltage applied to the control grid, the change in anode current is several times greater than that in the triode.

The pentode is to all intents and purposes a screened

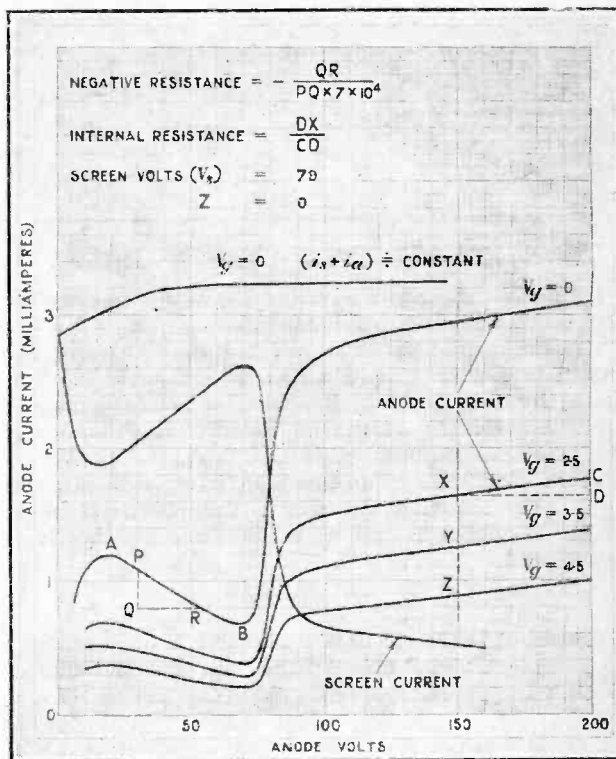

Fig. 1.—Typical curves for a screened grid tetrode. It will be seen that the screened grid current increases at the expense of the anode current and that negative resistance occurs at AB.

The Output Stage and the Pentode.—

valve with an additional earthed screen between the screening grid and the anode. This screen eliminates the negative resistance portion found in the S625 type, and increases the electron flow to the anode, by preventing emission of secondary electrons from the anode back to the auxiliary grid. Moreover, in the S625 the screen current increases at the expense of the anode current. These remarks are illustrated by the screened grid valve curves of Fig. 1. Moreover, like the screened grid valve, it has high "m" and "ρ" values. But the ratio of

the reader will only adopt the auto-suggestion scheme here, and say to himself $m = gp$, $m = gp$, etc., he will soon know all there is to be known about the business. I fail to see why one should go on talking about "mutual" conductance. "Conductance" by itself is to my mind quite sufficient, and I intend therefore to give the "mutual" part of the title its notice to quit.

The Pentode and the Moving Coil Loud Speaker.

The conductance of a valve is the change in anode current when the grid voltage is increased or decreased by 1 volt. Turning to Fig. 2, we have curves showing the relation between anode current and grid voltage, for various anode potentials. These are in reality conductance curves. If for any given value of anode voltage, say, we draw a horizontal line equal to one volt, an equivalent vertical line is the change in anode current for a change in grid volts of unity. Thus the change in anode current per grid volt is 1.8 milliamperes, and this is the "conductance." The value we have just found applies to the pentode, and is much higher than that for a triode. Examples of the latter were cited above, when for the LS5 class of valve we obtained a value of 800, this being microamperes. Converting to milliamperes, this becomes 0.8, which is about half that found for the pentode.

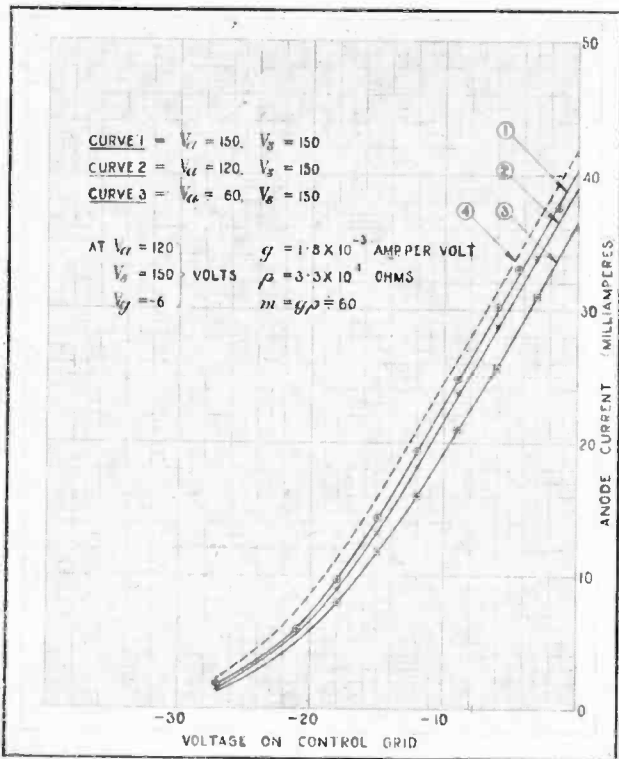

Fig. 2.—Grid volts-anode current curves or "conductance" curves of a two-volt pentode (P.M.2). The dotted curve (4) represents the characteristic when the anode voltage is higher than the screened grid voltage.

magnification factor to internal resistance is much higher than that for a triode, as the following examples will clearly show.

The internal resistance of an LS5A is about 2,700 ohms, and its magnification factor 2.2. On the other hand, the corresponding data for an LS5B are respectively 25,000 ohms and 20. The ratio $\frac{m}{\rho}$ in the first case is $\frac{2.2}{2,700} =$

$800 \mu A$, and in the second $\frac{20}{25,000} = 800 \mu A$. Thus

the ratio for a triode of the LS5 class seems to be more or less constant.¹ Now this ratio is extremely important. The reader has dropped across it before under the guise of "mutual conductance." It is usually designated by the letter *g*. Symbolically we have $\frac{m}{\rho} = g$ or $m = gp$. If

¹ It varies according to the valve design.

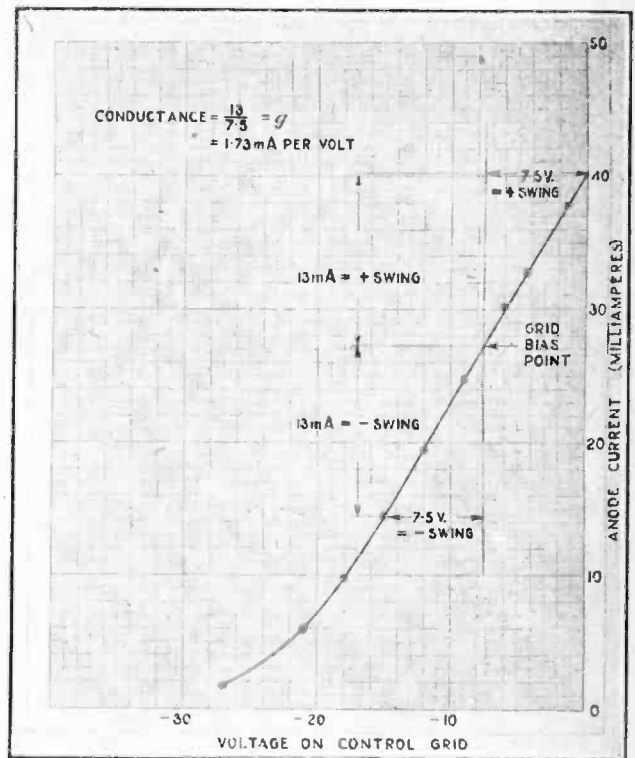

Fig. 3.—Diagram illustrating variation in anode current with grid voltage for a P.M.22. The screened grid voltage is 150 and the anode voltage 150. Note that *g* in Fig. 4 is for different screen and anode voltages.

From Fig. 2 we see that the pentode characteristics are substantially linear for a grid swing from 0 to 12 or 15 volts. At the mid-point, the anode feed current is about 27 mA when the screening grid and the H.T. are

The Output Stage and the Pentode.—

both 150 volts. This is quite high, and is comparable with triodes of the LS5A class. The internal resistance is 33,000 ohms, which is high for a power valve, but this is immaterial, since it is clear from Fig. 3 that for a grid swing of ± 7.5 volts the change in anode current amounts to 26 (± 13) milliamperes. Such a current variation is ample for average loud speaker purposes. Taking the case of a coil-drive loud speaker, we can assume its maximum impedance to be 4,000 ohms. This is small

should remember, however, that this method of computing the coil current is only permissible when the valve resistance is large compared with the coil impedance. It is not true in the case of an ordinary reed-drive speaker of 2,000 ohms nominal resistance, because its impedance at the higher audio-frequencies is comparable with the internal valve resistance.

A second series of curves for the pentode is given in Fig. 4. These correspond with the screened grid curves of Fig. 1. The influence of the earthed grid between screen and



The Mullard pentode power output valve. The four-volt type illustrated above (P.M.24) has a filament consumption of 0.15 amp. The maximum anode potential is 150 volts at which the makers claim that a total grid swing of about 21 volts (± 10.5) can be accommodated and that the mutual conductance is 2.3 mA per volt.

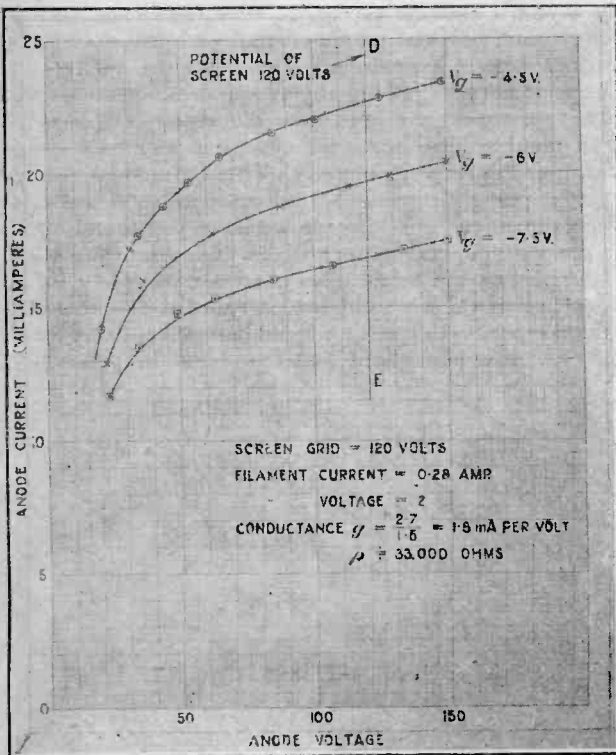

Fig. 4.—Anode volts—anode current curves for the P.M.22. Note that there are no kinks in the curves when the anode voltage is less than that on the screen. Compare Fig. 1.

compared with the internal resistance of the valve, i.e., 33,000 ohms. Since the coil impedance is negligible compared with the internal valve resistance, the presence of the coil does not affect the variation in anode current due to the signals on the grid. Thus the valve performance is portrayed by the curves of Fig. 2. For example, suppose the screening grid and the H.T. are both 150 volts, and the grid swing on each side of the bias point is 7.5 volts, then from Fig. 3 it is clear that the maximum current change in the coil will be 13 mA. Another method of finding the current through the coil is by aid of the conductance. This, as I said before, is the change in anode current per volt change on the grid. For our pentode $g=1.73$ mA. per volt. But the grid swing is 7.5 volts, so that the maximum coil current (A.C.) is $gV_g=1.73 \times 7.5=13$ milliamps, which is the value from Fig. 3. The reader should bear this in mind, because if the grid swing and the conductance are known the coil current can immediately be determined. He

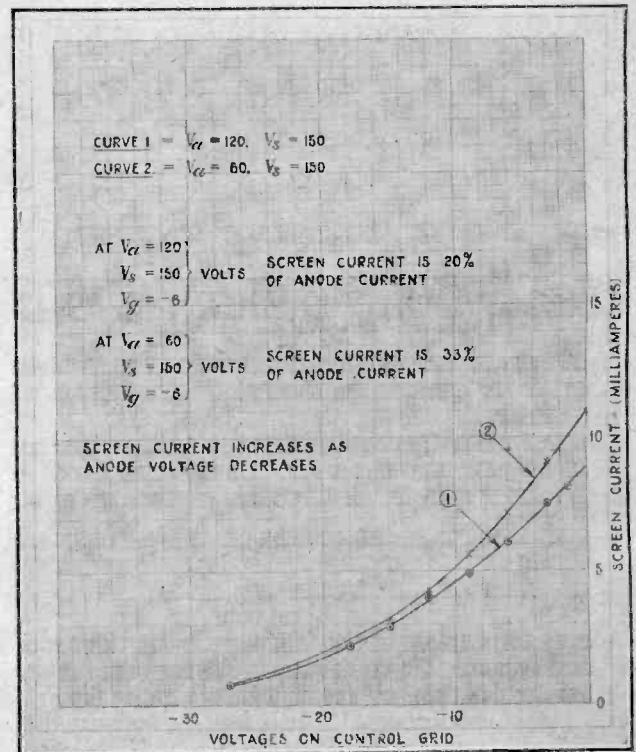

Fig. 5.—Grid volts—screen current curves for different anode voltages. The screen current rises slightly as the anode voltage falls but the effect is not marked.

The Output Stage and the Pentode.—

anode is to modify the electronic phenomena so that there is no negative resistance portion as shown at AB of Fig. 1. To the left of the line DE the anode is at a lower potential than the screen, but the screen does not drain away the anode current as in Fig. 1. Moreover, the anode current is substantially unaffected. The screen current is illustrated in Fig. 5, from which it is clear that at the lower anode voltages it is a much smaller *proportion* of the total electron emission than in the case of Fig. 1.

A further interesting feature of the pentode is the comparative closeness of the curves of Fig. 2 for any particular value of screen potential. Although the anode voltage is varied from 150 to 60, there is a comparatively small change in anode current. This is quite distinct

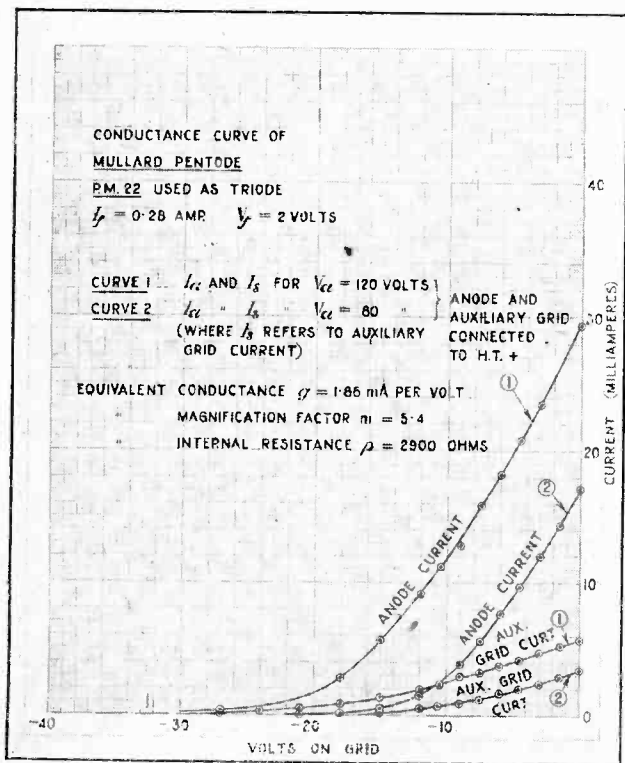

Fig. 6.—By connecting the screen and anode together the pentode can be made to function as a triode. The above curves represent the equivalent triode characteristics of a P.M.22.

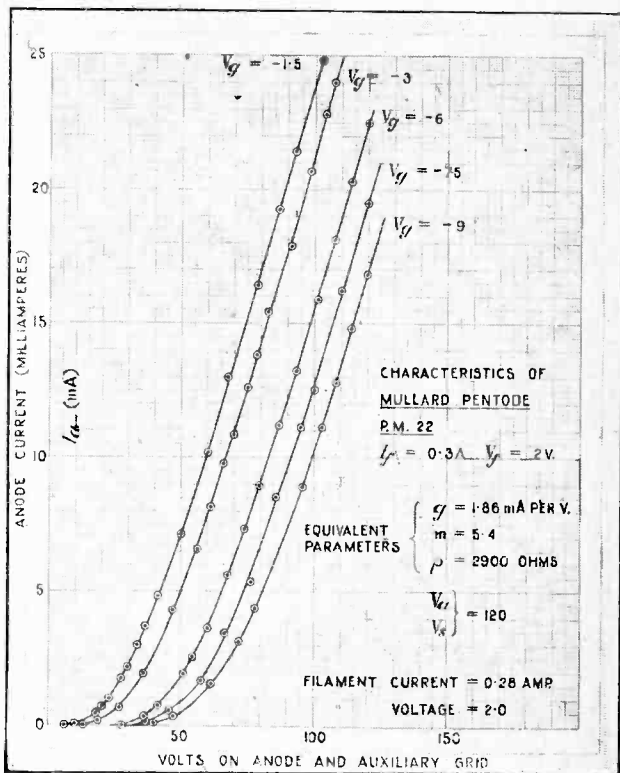

Fig. 7.—Anode and screen grid voltage plotted against current for a P.M. 22 connected to function as a triode.

from the triode where the separation of the lines is appreciable. In practice this is important, since it means that for the pentode, although the anode voltage varies considerably, the anode current is maintained. The argument can be crystallised by saying that the pentode has not only a high internal resistance ρ but a companionately high magnification factor m . The closeness of the curves depends upon a high value of ρ .

As a side issue, curves have been taken with the screen and anode connected together, thereby converting the valve into a form of triode. The results are illustrated in Figs. 6 and 7. The equivalent values are $m=5.4$, $g=1.86$ mA. per volt, $\rho=2,900$ ohms. Note that g is substantially the same as that when the pentode is used in the normal manner.

(To be continued.)

A NOVEL BATTERY LEAD.

THE existence of a large number of battery leads straggling down from the back of the receiver to the various batteries usually situated on the floor presents a very untidy appearance.

It is a very simple matter, however, to remedy this without going to the expense of buying special battery cords. All that is

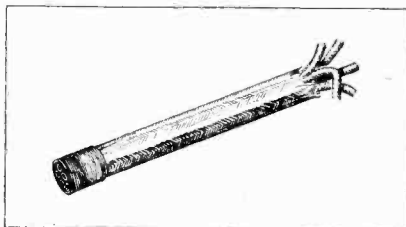

A tidy multiple battery lead.

needed is a mohair bootlace. If the metal tabs of the lace are cut off, it will be found that we have a flexible mohair tube of such a diameter that several ordinary single flexible leads can be threaded through it as shown in the drawing. On the whole, the arrangement presents a singularly neat appearance.

D. C.

SWITCH-OVER THREE

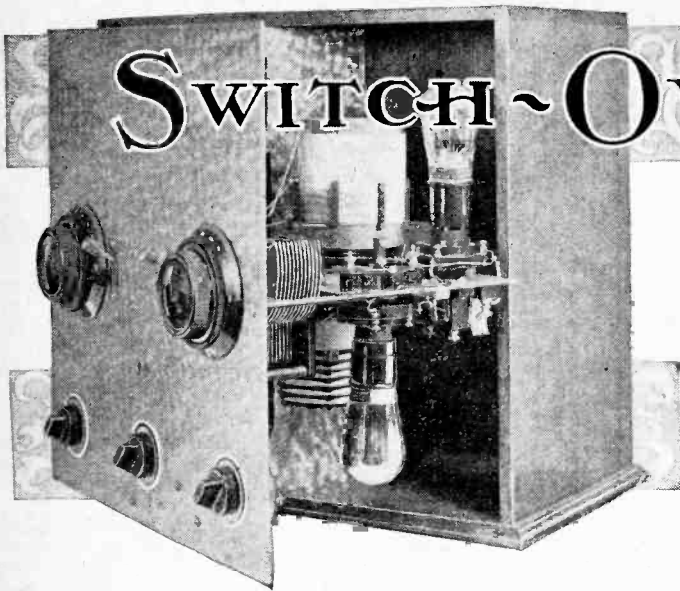

Coil Winding and Further Constructional Details.

By H. F. SMITH.

(Concluded from last week's issue.)

SPECIAL precautions must be taken in fitting the condensers, and it is essential that the vanes should be insulated from the metal panel in order to avoid a short-circuit of the grid bias batteries. As the Burndept condensers actually used in the receiver as described and illustrated are fitted with a spindle of insulating material the addition of a bush is not necessary as with ordinary patterns.

In the matter of the cabinet, it should be pointed out that, as the panel is not of standard dimensions, a specially made container must either be made or purchased. That illustrated is a simple affair with a fixed back, made to the writer's specification, and measuring 14in. by 14in. by 8³/₁₆in. deep inside. The panel is screwed to fillets fitted to top, bottom, and sides, with two runners arranged to act as supports to each end of the horizontal platform.

If ready access to the interior of the receiver is required, it would be preferable to fit a horizontal central batten across the back to carry two hinged doors.

It is considered unnecessary to describe in detail the short-wave coils, as they are of a kind used in a number of *Wireless World* receivers. The aerial-grid inductance consists of a single layer winding with 70 turns of 27/42 Litz, having a tapping at the 12th turn from the earthed end for connection to aerial, while the H.F. coupling is a standard "Everyman Four" transformer, preferably modified by disposing of the terminal screws in the manner to be shown in the practical wiring plan.

The transformer should be mounted with primary and neutralising windings nearest to the base; it must not be inverted.

The long-wave aerial-grid coil is wound on a ribbed "Becol" former, slotted as shown in Fig. 4; in each rib there are 10 slots, approximately ³/₁₆in. deep and ³/₈in. wide. As the thickness of covering in different makes of wire varies slightly, it is recommended that the exact size should be found by trial; the slots should be large enough comfortably to accommodate 25 turns of No. 28 D.C.C. wire. There is thus a total of 250 turns, with a spacing of ¹/₈in. between each of the ten sections. The slots may be cut out with a hacksaw and finished off with a warding file, or they may be turned in a lathe. The tapping for connection to aerial is made at the 60th turn from the low potential end of the coil; assuming the winding to be started at this end it will be at the tenth turn in the third section. In order that the finished coil may coincide with the corresponding short-wave inductance, the standard 4in. former is reduced in length to 3¹/₂in., although this is not strictly necessary provided the relative position of the winding with respect to vertical screen and platform is unchanged.

For the long-wave intervalve transformer a similar method of construction is adopted; in fact, the secondary winding is the same, but the slots are cut in the 4in. former in the manner shown in the second drawing in Fig. 4. Over the low potential end of the secondary is the primary winding, having 50 turns of No. 38 D.C.C. wire in a single layer, separated from the secondary by six strips of Paxolin or similar insulating material, ³/₃₂in. thick, and measuring 1¹/₄in. long by ³/₈in. wide. These should be deeply scored

longitudinally with any sharp instrument, and then bent to the form of a widely-opened "V" in order that they may fit snugly over the ribs. One of the strips should be fitted with a No. 8 or 10 B.A. screw at each end for anchoring the ends of the winding, and also to serve as junction points for external connections. If no special attempt is made to wind the turns closely it will be found that they occupy a winding length of about ¹/₄in., which is correct.

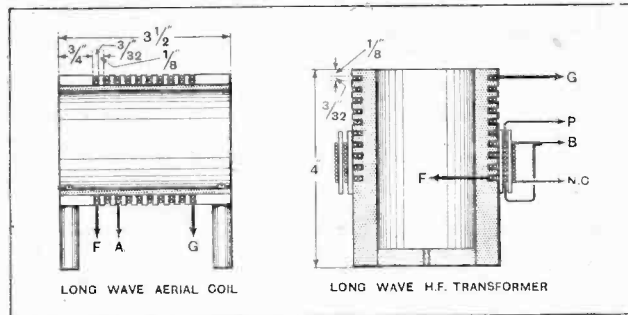

Fig. 4.—Construction of the sectionally-wound long-wave coils, showing relative positions of the various windings.

Switch-over Three.—

The neutralising winding, also having 50 turns of No. 38 D.C.C., is wound immediately over the primary, from which it is separated by six more Paxolin strips, again $\frac{1}{2}$ in. thick, one of which carries two screws for the ends of the coil. The ultimate connections of all these terminal points is shown in Fig. 4, the lettering of which corresponds with that in Figs. 1 and 5.

In wiring the receiver it is recommended that as many leads as possible should be put on before mounting the coils in position, care being taken, however, that no wires cross the position they are to occupy. Moreover, it is suggested that the leads between the switch and H.F.

small ebonite packing disc was used to compensate for its lack of thickness as compared with ordinary panel material.

For the high-frequency amplifying stage it is intended that an "H.F." valve of some 20,000 to 30,000 ohms should be used in the socket marked V_1 . For V_2 the detector, an "R.C." valve of some 50,000 to 70,000 ohms is suitable, although one of lower impedance gives good results but less sensitivity; it is quite adequate for work at short range, but its use will necessitate the addition of a third cell to the bias battery G.B.₂. A power valve, or preferably, one of the "super-power" variety, should be used as V_3 in the output stage.

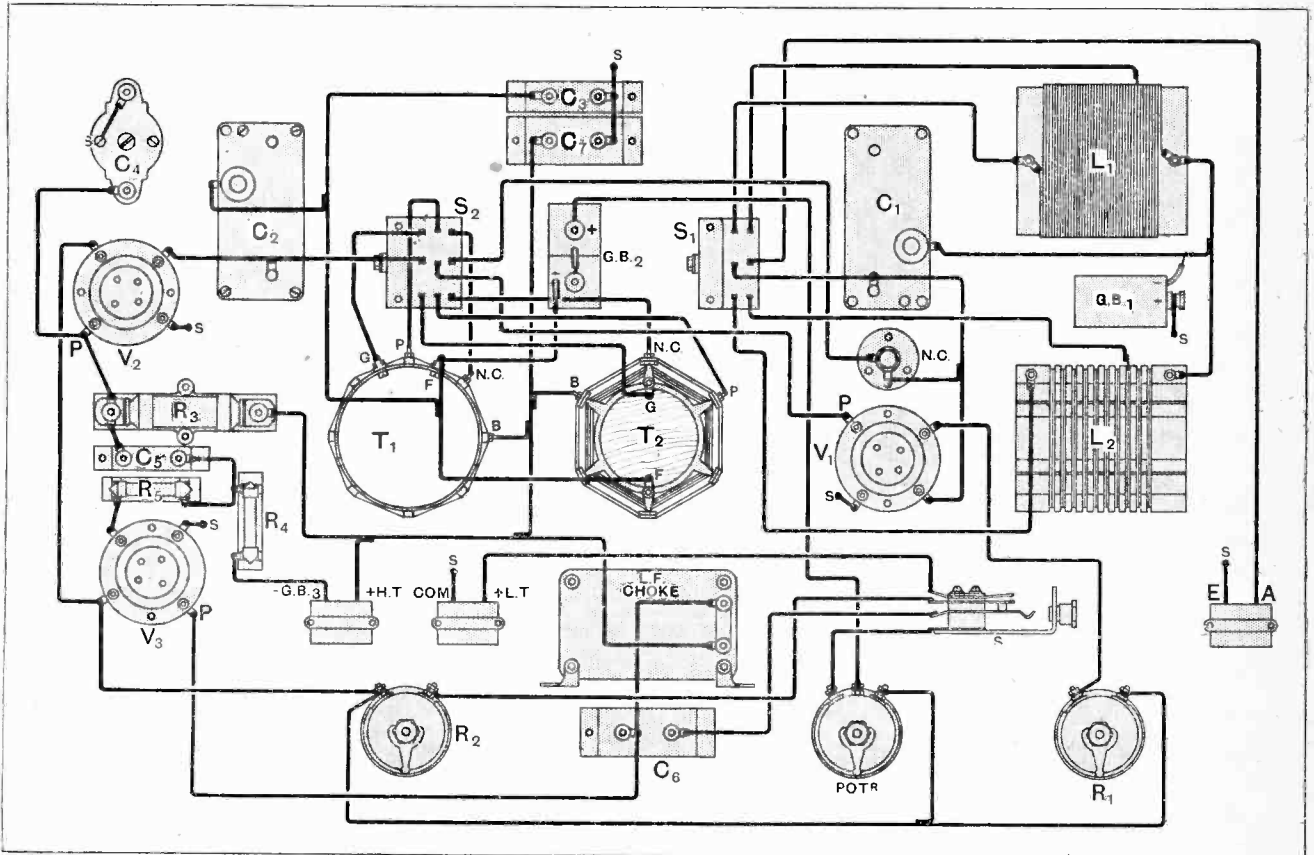

Fig. 5.—The practical wiring plan. Connections to the screen are marked S. Lettering corresponds with that in Figs. 1 and 4.

transformer should be soldered to the switch contacts before the coils are finally secured. If the less accessible connections are put on first the set will be found no more difficult to wire than one built on more conventional lines. Components are so arranged that only two high potential H.F. leads (those joined to the grid of V_1 and plate of V_2) pass through the screening partitions.

The practical wiring plan is given in Fig. 5, which is drawn in such a way that the components are shown in as nearly as possible their actual relative positions without unduly complicating matters. The various connections to the screen (and consequently to negative L.T., negative H.T., and G.B. positive) are indicated by the letter "S." It will be observed that the frame of the jack is in metallic contact with the panel, although a

Provision for separate H.T. voltages for the different valves is not considered as being necessary for a receiver of this kind, particularly if the usual maximum of 120 volts is not exceeded to any extent. If it is, an extra terminal may be added for the H.F. valve, or, if transformer L.F. coupling is adopted, for the last stage.

Initial tests should be carried out on the medium broadcast waveband with the switch levers in the "down" position. The potentiometer slider should be set near the negative end of its resistance winding, being adjusted for loudest signals as soon as anything is heard. The next step is to neutralise; this is carried out in the manner described on many occasions in this journal, particular care being taken to balance as accurately as possible.

We now come to a matter which may conceivably give

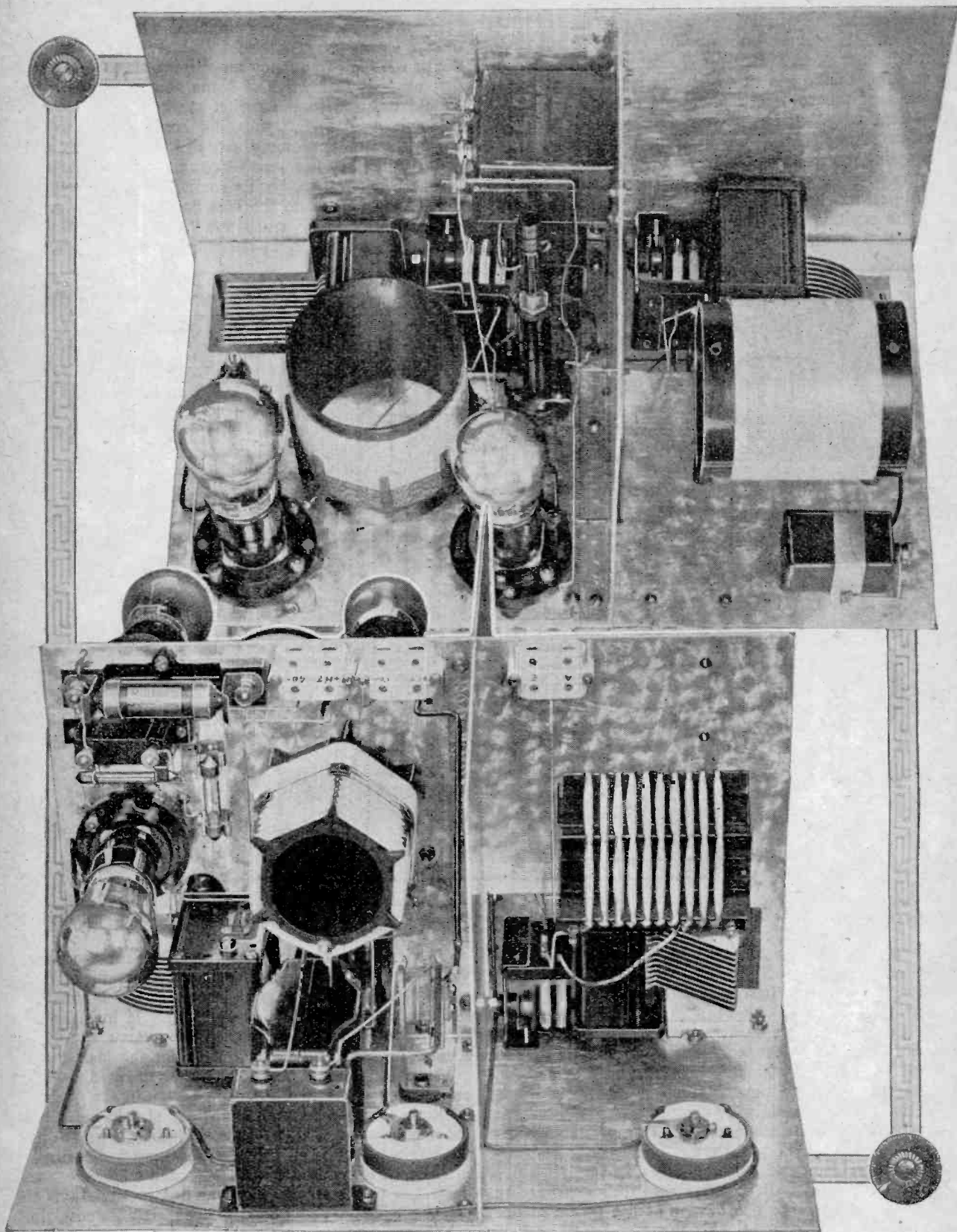

Switch-over Three.—

rise to a little trouble. As the neutralising condenser is not duplicated it is necessary that the same capacity should balance both medium and long-wave sides of the receiver. In practice it was found the same setting held good, as was intended, on changing over. If for any reason it fails to do so, it should be observed whether an increased or decreased neutralising capacity is required to give stability on the long waves. If the former, two or three turns should be added to the neutralising winding; if the latter, a similar number of turns should be removed. A still easier way out of the difficulty (which, it should be emphasised, is unlikely to arise) is to fit separate neutralising condensers for each circuit; to do this the grid of V_1 should be joined directly to the left-hand blade of the switch S_2 instead of through the balancing capacity. The individual condensers are now interposed in the leads joining the coil terminal points marked N.C. and the switch contacts.

As the operation of the controls is essentially similar to that of any modern receiver, it need not be described. Except for the points already discussed, no special pitfalls are likely to be encountered. Experiments may be tried with different aerial tappings on the coils L_1 , L_2 , particularly if requirements in the way of selectivity are exceptional, or if the dimensions of the aerial differ widely from the usual standard.

When dealing with possible sources of trouble, the writer should have drawn attention to the need for avoiding possible short-circuits when fitting filament resistances to a metal panel. In this matter, our choice of suitable components is strictly limited, but no trouble will be experienced with Igranic rheostats, provided the precaution is taken of drilling an oversize hole through both indicating disc and panel to preclude the possibility of accidental contact between spindle and metalwork. The same applies, of course, to the potentiometer.

Finally, a suggestion may be offered as to simplifying

This receiver is available for inspection by readers at the Editorial Offices of this journal, 116/117 Fleet Street, London E.C.4.

the building of the metal "chassis." Instead of making the horizontal platform in one piece, with apertures cut out for the variable condensers, the form of construction shown in Fig. 6 may be found more convenient. As will be seen, the vertical screen is a single sheet of metal,

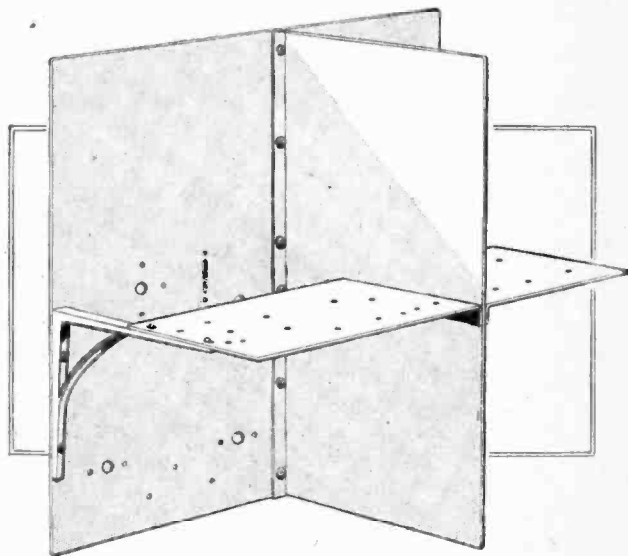

Fig. 6.—A suggestion for simplifying construction of the metal chassis.

while the platform is made in two parts, supported at their outer extremities by metal brackets, and at their inner ends by flanges screwed to the vertical screen. The width of these platforms should be just sufficient to afford a clearance for the variable condensers; if necessary, they may be set slightly above or below the centre line, in order that allowance need not be made for a projecting spindle extension.

Queen's Park Wireless Club.

Among interesting events in recent programmes of the Queen's Park Radio Society have been a demonstration by the Celestion Loud Speaker Co. and a talk by Mr. Biddle on short-wave reception. In the loud speaker demonstration gramophone records were reproduced with a seven-valve amplifier, which gave excellent tone and volume on two large cone-type loud speakers.

The club is at present engaged on the construction of an amplifier.

Hon. secretary, Mr. F. Batho, 37, Enbrook Street, Queen's Park, W.10.

"All Wave Four" Demonstrated.

The Wireless World "All Wave Four" receiver was demonstrated by Mr. Reuben Heaton at the last meeting of Slade Radio, Birmingham, with excellent results. The society's H.T. eliminator was employed. An interesting feature of the evening was a test of a number of loud speakers concealed behind a screen, members voting on the respective merits of the different instruments. The results were, in many cases, very enlightening.

Hon. secretary, Mr. H. Clews, 52, St. Thomas Road, Erdington, Birmingham.

Meter Economy

"Getting the most from your meters" was the subject of an entertaining talk given by Mr. H. A. Brown at the last meeting of the Tottenham Wireless Society. While voltmeters are usually supplied in two ranges, one suitable for L.T. readings and the other for H.T.,

NEWS FROM
THE CLUBS.

milliammeters, said Mr. Brown, were not available in multi-range varieties, and the demands upon one's purse often preclude the luxury of several instruments. The speaker advised the purchase in the first place of a really good meter having a low scale. This could be brought up to any required reading by the use of external shunts. Ohm resistances could be easily made from old filament resistances; when made the resistance should be embedded in sealing wax.

On Saturday, June 30th, a party of members visited Croydon Aerodrome, where they were able to study the arrangements for the arrival and despatch of 'planes.

Hon. secretary, Mr. F. E. R. Neale, 10, Bruce Grove, Tottenham, N.17.

Tracking an Oscillator!

Something new in field days was attempted by the Bradford Radio Society on Saturday, June 30th, when four parties of members, each provided with a small portable receiver and frame aerial, endeavoured to track a wily oscillator, who was known to be concealed in an area of approximately two miles square. No

party was successful in running him to earth, although Mr. Carter's party came within a hundred yards of the offender.

Some amusing incidents occurred. Accidental short circuits considerably overheated several valves, while one member, forgetting that his telephone leads were attached to the set, gave chase to a rabbit!

Owing to the success of this event, another oscillator hunt will probably be held in September.

Hon. secretary, Mr. E. A. Cowling, 1145, Leeds Road, Bradford.

A Visit to Trafford Park.

A visit to the wireless Department of Messrs. Metropolitan Vickers, Trafford Park, Manchester, on June 16th was an attractive fixture in the programme of the Wigan and District Technical College Radio Society. Forty members of the society were conducted over the shops by Mr. N. P. Hinton, the chief engineer, and three assistants. The greater part of the work in hand was concentrated on sets working entirely off the mains and employing valves with separately heated cathodes. The entire process of manufacture of coils, condensers, and other components was carefully examined, and not the least interesting part of the afternoon was a visit to the testing laboratory. By the kindness of the directors, the party was entertained to luncheon.

On Saturday last, July 7th, the Society held a test of portable sets at Rivington Pike.

Hon. secretary, Mr. M. M. Das, B.Sc., Library Street, Wigan.

USEFUL DATA CHARTS. (No. I.)

A New Series of Abacs for Solving Practical Problems.

By R. T. BEATTY, M.A., B.E., D.Sc.

The chart on the facing page is arranged to readily reveal the relationship between frequency and wavelength. Continuing from this simple scale a series of abacs for solving practical problems relating to receiver design are to be included in future issues. They will include scales relating to resistance, capacity, inductance and wavelength determinations.

MULTIPLICATION, division, and similar exercises in arithmetic are fatiguing operations, and attention has been drawn by an unknown poet to their vexatious nature and to the disturbance of mental equilibrium produced by fractions in particular. In many cases, however, where the same type of sum has to be done over and over again the answer can be found very simply by merely laying a straight-edge across three lines and reading off the number required.

The abac (Latin *abacus*) was originally a framework carrying a number of parallel wires on which beads were strung, and was used to teach arithmetic to the children of ancient Rome; children in this country used a similar device till quite recently. The introduction of the modern abac in 1884 was due to M. d'Ocagne, a French engineer, and his methods were taken up with enthusiasm by engineers throughout the world.

What is an Abac?

A simple abac is made by drawing three parallel uniform scales. If we put a ruler across the diagram

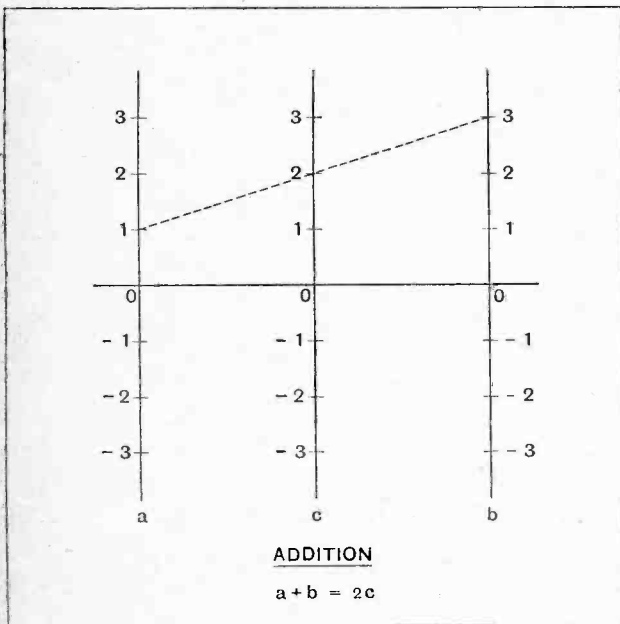

How addition is accomplished by an abac. Half the sum of the distances numerically set out along a and b is revealed on c.

we see that the height of the intercept on the centre line reckoned upwards from the line of zeros is half the sum of the intercepts on the outside lines; that is, $a + b = 2c$; thus, along the dotted line $1 + 3 = 2 \times 2$. If we reverse the (a) line we get $-a + b = 2c$, i.e., $-(-1) + 3 = 2 \times 2$. Again, by reversing the middle line the equation

solved becomes $a + b = -2c$, or $1 + 3 = -2(-2)$.

Multiplication and Division.

If we draw logarithmic scales in which the equidistant divisions represent 1, 10, 100, and so on, we have an abac for multiplication. For when we want to multiply together such powers of 10 as 10^1 and 10^3 we add the indices and obtain 10^4 . Thus we find that $a \cdot b = c^2$,

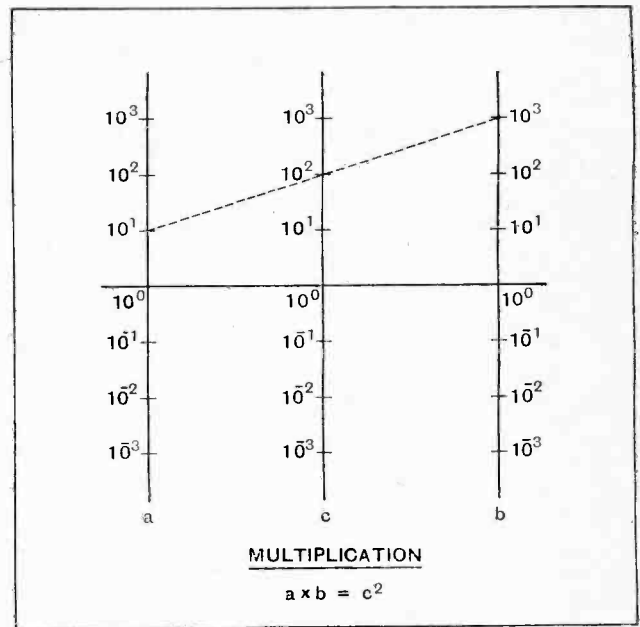

Multiplication and division are achieved by the use of logarithmic scales.

or $10^1 \times 10^3 = 10^4$, the square of 10^2 . Again, if we are given the equation $a \times 10b = c^2$, we move the b scale up by one space: the dotted line then shows that $10^1 \times 10 \cdot 10^2 = 10^4 =$ the square of 10^2 .

The abac which is given this week does not require a ruler; we simply read kilocycles on one side and metres on the other. Each double scale is produced by taking two logarithmic scales and fitting them together with one reversed. The rule is that kilocycles \times metres = 300,000, and if this product is made correct at any one point it will be correct at all other points.

Most people think in cycles at low frequency, metres at high frequency. Thus, while we may be familiar with a tuning note, of a frequency of 1,000 cycles or 1 kilocycle, few would recognise it as a 300,000-metre wave. Similarly, a 5-metre wave is easier to think of than its equivalent of 60,000 kilocycles, though in time we shall no doubt come to use megacycles (millions of cycles) for these high frequencies.

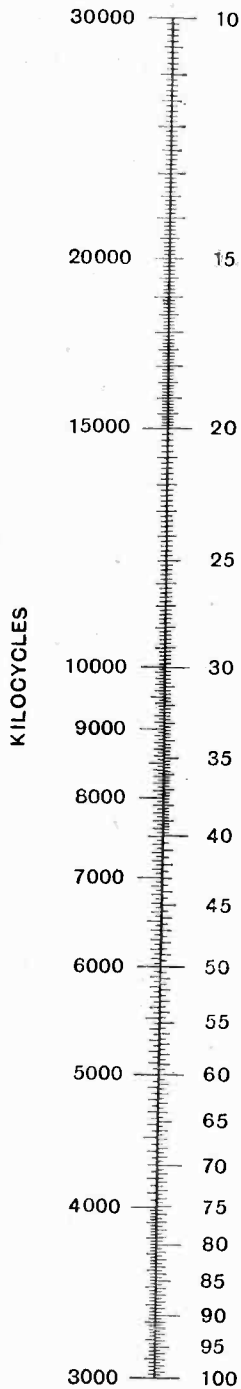

SHORT WAVE
10-100 METRES

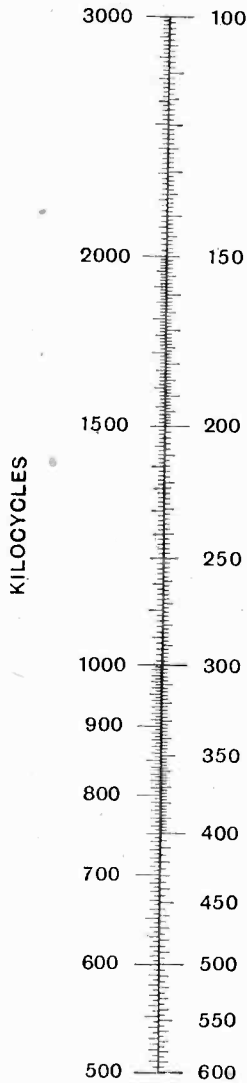

MEDIUM WAVE
100-600 METRES

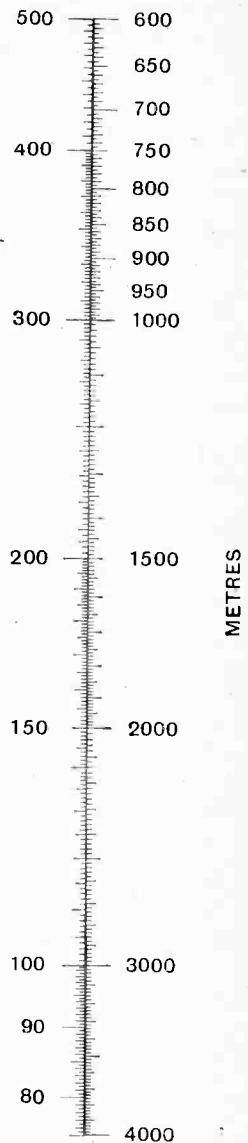

LONG WAVE
600-4000 METRES

FREQUENCY AND WAVELENGTH

W. W. ABAC

No 1

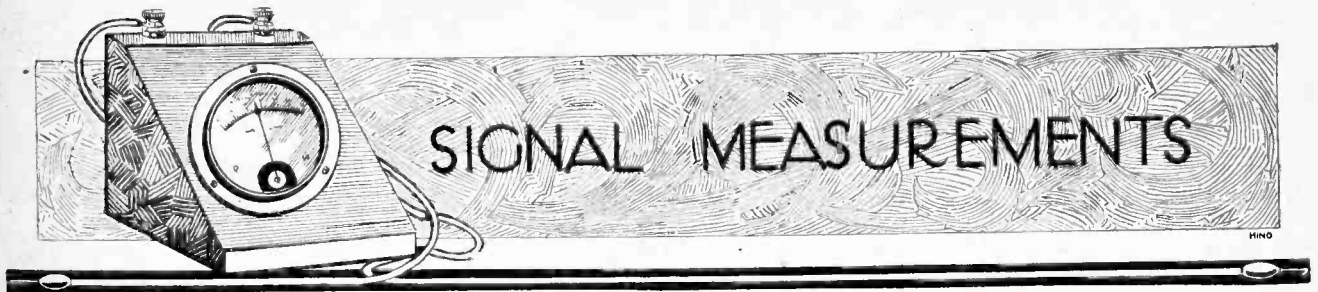

Comparative Tests Without Special Apparatus. By "RADIOPHARE."

MANY of our difficulties with the operation of wireless receivers are due to the fact that high- and low-frequency voltages cannot be measured by ordinary instruments. It is now generally recognised that a D.C. voltmeter is almost essential; but, after all, it only shows that our set is being supplied with the energy necessary to put it into a condition for performing its function, and gives no indication of how the signal is surviving the successive processes of H.F. amplification, detection, and L.F. magnification. For this, we have to rely on that notoriously unreliable organ, the human ear. Admittedly it is the final arbiter—there is sometimes a tendency to forget this—but it does not retain its impressions, and, when trying the effect of an experimental alteration, it is almost impossible definitely to decide whether the change is for better or worse unless a quick comparison is possible, and in any case the variation in intensity has to be considerable for it to be appreciable.

At this point one may ask if a gain in signal strength which is not sufficiently great to be at once audible is worth worrying about. In the long run, it probably is, but this is hardly the point; the excellence or otherwise of even the simplest wireless receiver depends on many details, and although an improvement at any one point may fail to produce noticeably louder signals, the sum of several such gains will be perceptible.

As suggested above, quantitative measurements can only be made with the help of special apparatus to which the average amateur has not access; however, this need not deter him, as very useful comparative data can be obtained with the help of ordinary instruments.

When endeavouring to improve the sensitivity of a receiver, attention will mainly be concentrated on its high-frequency amplifying side, and fortunately it is

quite an easy matter to obtain visual indication of an increase or decrease of its output, assuming the transmission to be constant. All that is required is a milliammeter, which is inserted in series with the detector valve anode in the position shown at A in the diagram; a gain in signal strength is shown by an increased change in current as compared with that flowing when no signal voltage is applied. If the valve is functioning as an anode bend rectifier, this change will be in an upward direction, a decrease in current taking place with the leaky grid condenser method of detection; this method is less convenient.

Several precautions should be taken to avoid the possibility of misleading results; and in particular it is essential that L.T., H.T., and grid bias voltages should remain constant while comparisons are being made. Above all, one must beware of incidental reaction effects. When the detector valve is of the high-impedance type, with a high value of anode resistance,

the ordinary milliammeter will be insufficiently sensitive to give a clear reading, but this difficulty may be overcome by the temporary substitution of a smaller resistance, and, if necessary, of a valve having a lower impedance, with an increased negative bias if it is to rectify on the lower bend.

The comparative measurement of audio-frequency voltages after rectification is more difficult, because modulation is always varying. However, the tuning note is

constant enough to be a useful help. To get an indication of the rectified output from the detector, the milliammeter is transferred to point B (or C) in the anode of the 1st L.F. valve, the bias of which is increased to about twice its previous value in order to convert it from an amplifier to a rectifier. Any increase in anode current over the steady value will be a measure of the low-frequency voltage applied to the grid.

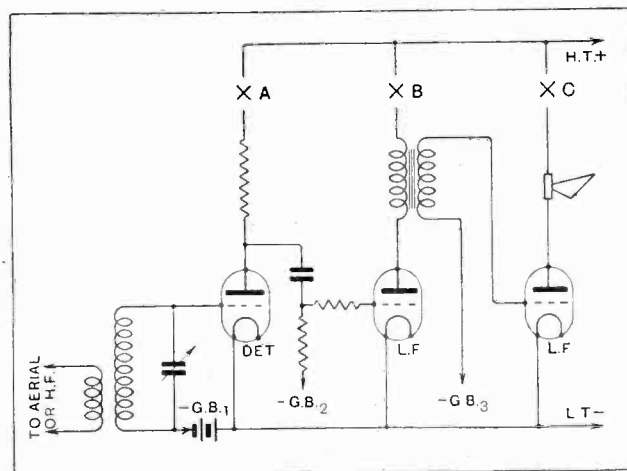

How to connect a milliammeter for obtaining visual indication of comparative signal strength at each stage.

NEW APPARATUS

A Review of the Latest Products of the Manufacturers.

PYE ANTI-CAPACITY VALVE-HOLDER.

The minimum of insulating material has been used in the construction of these valve holders yet their strength is remarkable. Being of the rigid type, they can be used effectively for H.F. or L.F. stages but there is no reason why they should not be used for the detector stage if mounted on sponge rubber.

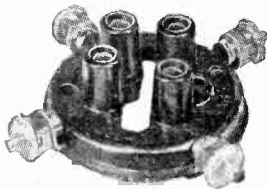

The anti-capacity valve holder made by Messrs. W. G. Pye, Granta Works, Cambridge.

Fitted with soldering tags only, the price is 8d., and with square undercut terminals of the type fitted to Pye chokes and transformers, 10d.

o o o o

TRIX THREE-BASE.

For the time being the low-frequency side of modern receivers has reached a

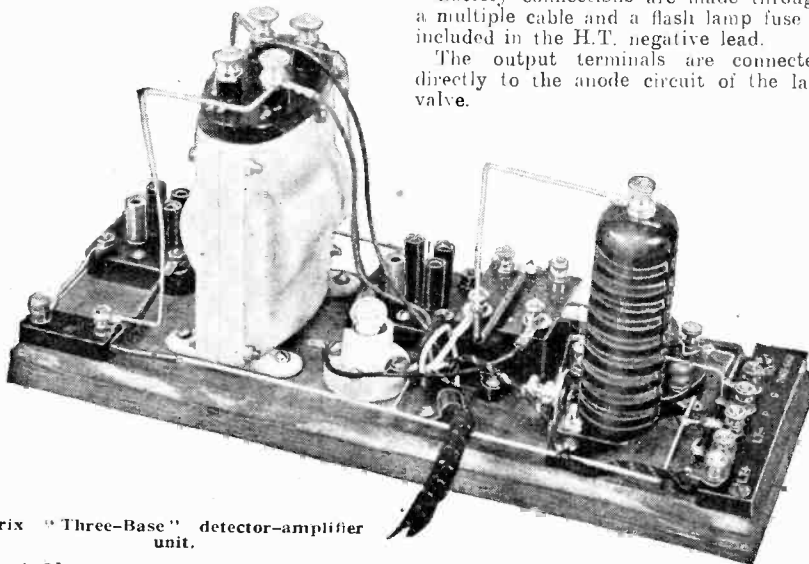

Trix "Three-Base" detector-amplifier unit.

A 21

state of stability and a resistance-coupled stage followed by transformer coupling is now almost universal practice. Messrs. Eric J. Lever (Trix), Ltd., 8/9, Clerkenwell Green, London, E.C.1, have taken advantage of this state of affairs to produce a three-valve unit for L.F. amplification which can be incorporated in every type of receiver and greatly simplifies construction. With the exception of the R.I. Varley general purpose transformer, "Trix" components are used throughout and the whole unit is produced for the reasonable figure of 45s. There is no limit to the number of valves or types of H.F. coupling which may be connected in front of the unit, a fact which should appeal to the prospective experimenter.

The first valve is, of course, the detector. Direct connection is made to the grid so that anode bend or leaky grid rectification can be used at will by the addition of suitable components before the detector. The detector valve holder is of the anti-microphonic type, the two L.F. valves being mounted in rigid holders. Following the detector is the compact Trix R.C. unit with a radio-frequency choke for capacity controlled reaction. The latter feature makes the "Three-base" suitable for incorporation in sets of the Mullard Master Three and Cossor Melody Maker type.

Battery connections are made through a multiple cable and a flash lamp fuse is included in the H.T. negative lead.

The output terminals are connected directly to the anode circuit of the last valve.

A brief test showed the amplifier to be stable and extremely good quality was obtained, there being no limit in the choice of suitable valves and battery voltages.

o o o o

BULGIN BASEBOARD NEUTRALISING CONDENSER.

A novel point of construction in this condenser is the single bearing in the base which supports the moving vanes. This bearing is of large diameter and

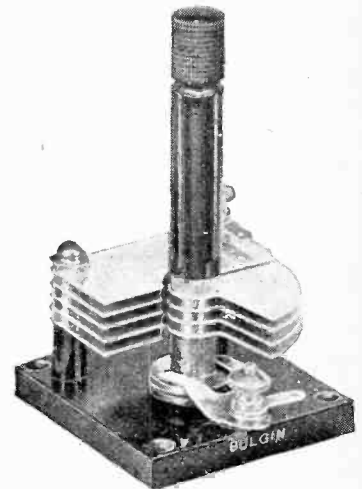

Bulgin baseboard neutralising condenser.

carries a wide shoulder which effectively prevents side play, an important point in view of the fact that considerable leverage is possible with the long extension handle. A fibre friction washer fitted underneath the shoulder ensures smooth action and the requisite tension is applied by a forked spring which is also used to pick up contact with the moving vanes.

The rated maximum capacity is 65 micro-mfd. and the measurements on the specimen submitted for test showed the maximum to be 63 micro-mfd. with a minimum of 2.5 micro-mfd. The price of this condenser, which is made by Messrs. A. F. Bulgin & Co., 9/11, Cursitor Street, London, E.C.4, is 5s., and there are two others with maxima of 35 and 50 micro-mfd. each priced at 4s. 9d.

The construction and finish are in every way excellent.

WESTON RADIO TESTER.

This tester has been developed by the Weston Electrical Instrument Co., Ltd., 15, Gt. Saffron Hill, London, E.C.1, with the object of combining in a single instrument the means of measuring all the direct currents and voltages in a wireless receiver. The nucleus of the instrument is a sensitive Weston meter with a resistance of 1,000 ohms per volt, a value which ensures accuracy when measuring the voltages given by dry cell H.T. batteries or battery eliminators. By means of a rotary selector switch, shunts and series resistances are automatically connected to the meter to give the following ranges:—

	Voltage Range.	Current Range.
H.T.	0-200	0-20 ma.
L.T.	0-8	0-0.4 amp.
Grid bias	0-20	—

The first function of the tester, therefore, is that of a multi-range voltmeter; but this is only one of the many parts played by this versatile instru-

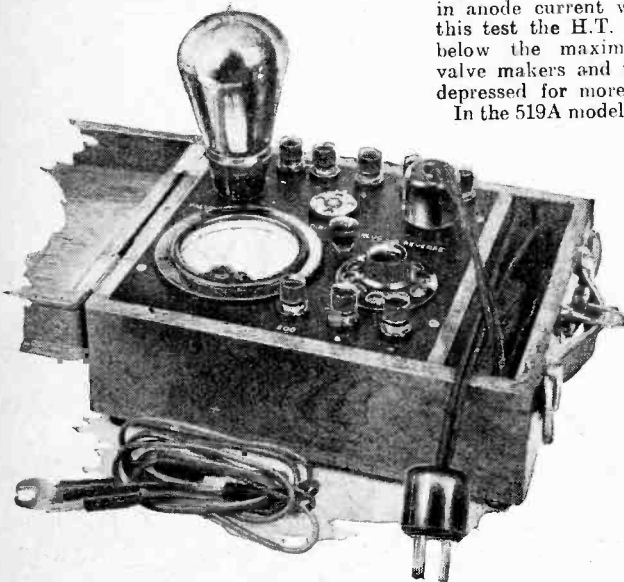

Weston radio tester for universal D.C. measurements on wireless receivers.

ment. Probably the most important use to which it may be put is that of observing the D.C. characteristics of a valve under actual receiving conditions. For this purpose three valve holders are fitted to the instrument panel. The valve to be tested is inserted in the left-hand socket and connection to the receiver is made through plugs and leads to the empty valve holder in the set. Two alternative sockets are provided on the tester in order that the polarity of the L.T. leads may be correctly applied to the meter. With this arrangement the actual voltage across the filament pins may be measured while the valve is taking current, and, in addition, the filament current, anode current, grid voltage and H.T. voltage may each be measured in turn. The makers point out, however, that the H.T. voltage will be reduced by the volt-drop in the external coupling circuit. This reduction will, in general,

be less than 1 per cent. for H.F. or L.F. transformers, but in the case of resistance coupling is indefinite and it becomes necessary to make a direct reading of the H.T. voltage by connecting the battery to the special terminals provided on the instrument. The same caution is necessary when interpreting the grid bias voltage, the volt-drop in this case being due to the current taken by the measuring instrument itself. However, there are no corrections necessary to the anode current readings and it is possible with this arrangement to adjust the grid bias of a L.F. valve to its correct value by observing the movements of the needle while signals are being received.

A switch marked "Grid Test" is provided for the purpose of disconnecting the G.B. battery and connecting the grid of the valve direct to L.T.+. If no change takes place in the anode current a disconnection in the grid circuit or run down G.B. battery is indicated, but if every thing is in order a considerable increase in anode current will result. In making this test the H.T. volts must be reduced below the maximum recommended by valve makers and the key should not be depressed for more than a few seconds.

In the 519A model complete characteristic curves may be taken by connecting the L.T., H.T., G.B. batteries from the receiver to special terminals provided for the purpose, and a preliminary test can be made to find whether the grid or plate is touching the filament. In the 519 model these terminals are omitted and the tests are restricted to measurements on valves operating under receiving conditions; but the meter can still be used for battery tests and for the innumerable continuity tests to which a multi-range meter can be applied.

The price of the 519A model is £15 15s. and the model 519 without terminals for taking valve characteristics is £13 10s.

A NEW "DEVICON" CONDENSER.

The Radio Devices Co., Newdigate Street, Nottingham, have revised the design of their well-known "Devicon" condenser, and now offer it to the public in two capacities (0.0003 and 0.0005 mfd.) at the extremely reasonable prices of 4s. 9d. and 5s. The condenser vanes and end-plates are now constructed of hard rolled aluminium, which is dipped to give a pleasing matt finish.

The 0.0005 mfd. model submitted for test had a maximum capacity of 0.00048 mfd. and a minimum of 41 micro-mfds. The plates are designed to give a straight line frequency tuning law.

The bearings are substantial, and an adjustable friction band is fitted to the spindle where it projects from the bottom

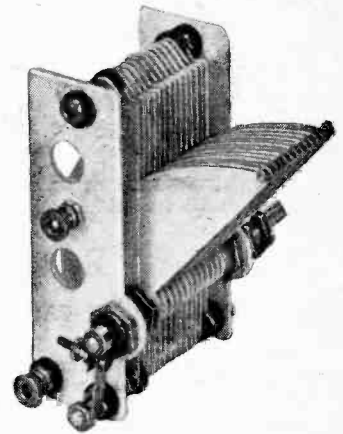

"Devicon" S.L.F. condenser.

end-plate. The insulation throughout consists of best quality ebonite bushes and washers, located in the metal end plates.

o o o o

IGRANIC THREE VALVE SHORT-WAVE SET.

In connection with the review of this receiver which appeared in the issue of June 27th, it should be noted that the extra coils which sell at 35s. per pair are for short waves (69-120 metres); additional coils for normal broadcast wavelengths (250-520 metres) and long waves (1,000-2,000 metres) are priced at 45s. per pair. Also the prices quoted for complete receivers include Marconi royalties.

CATALOGUES RECEIVED.

Mullard Wireless Service Co., Ltd., Denmark Street, London, W.C.2. Revised leaflet No. W.A.16 of the Mullard "Permacore" transformer, and leaflet V.R.65 describing the P.M.12 and P.M.14 screened grid valves.

o o o o

Goodmans, 27, Farringdon Street, London, E.C.4. Illustrated price list of parts for constructing Goodman's cone loud speakers.

o o o o

London Radio Manufacturing Co., Ltd., Station Road, Merton Abbey, London, S.W.19. Leaflets describing Orphean cone loud speakers and cone drive unit.

o o o o

Burne-Jones and Co., Ltd., 288, Borough High Street, London, S.E.1. Illustrated leaflets dealing with each of the following Magnum products:— Moving coil speakers, "Roadside Four" Portable, "1929 Purity Three" Receiver, Standard wave trap, H.F. chokes.



CURRENT TOPICS

Events of the Week in Brief Review.

LAST INSTALMENT: THE LICENCE!

A Bristol "pirate" pleaded that he was still paying for his set by instalments, and had hoped to take out a licence when the payments were concluded.

○○○○

A DISSATISFIED ALDERMAN.

"The programmes are unsuitable, and the transmission is very unsatisfactory." —Alderman H. Robson, of Bournemouth, referring to a wireless installation in the Corporation Café.

It is understood that the B.B.C. is progressing as well as can be expected in the circumstances.

○○○○

SIAMESE PRINCE AND THE SHORT WAVES.

The Crown Prince of Siam is well-known as a short-wave enthusiast. Recently he inspected the short-wave equipment at 3LO, Melbourne. On his return to Siam he issued instructions in his capacity of Minister of Communications that the Siamese Naval Radio Department should listen for 3LO and render official reports.

○○○○

ANOTHER USE FOR THE LOUD SPEAKER.

In an effort to induce more careful driving on the French roads, the police of Beauvais have equipped a car with amplifying equipment and a loud speaker. Reckless motorists in the Beauvais district run the risk, therefore, of being deafened by stern warnings from the police car which is now touring the neighbourhood.

○○○○

RADIO-TELEPHONY IN AERIAL DRILL.

The brilliant display of air drill carried out at Hendon on Saturday, June 30th, by No. 56 Squadron was repeated on Friday and Saturday last at the R.A.F. Display at Blackpool.

Each machine in the Squadron was equipped with a short-wave receiver, while the leader's machine also carried a transmitter. During the flight various spectacular evolutions were carried out on the leader's word of command, the stunts including looping the loop, flying in line, and re-forming squadron.

A 23

BRITISH WIRELESS ON ITALIAN AIRSHIP.

Readers who have followed the course of events in the rescue of General Nobile and the crew of the Italian airship "Italia" will be interested to learn that the explorers' wireless receiver was a Burndept short-wave set (Mark IV).

○○○○

TELEPHONY MESSAGES FOR FISHERMEN.

The well-known wireless station at Scheveningen (Holland) now issues a daily telephony message for the benefit of the Dutch herring-boats at work in the North Sea, writes the Hague correspondent of the "Daily Mail."

The messages are sent out on a wave-length of 1.875 metres every day except Sunday at 5.45 p.m.

RADIO WHOLESALERS UNITE.

To further the interests of the wholesale radio trade, the Radio Wholesalers' Federation has been formed with offices at 35, Sicilian House, Sicilian Avenue, London, W.C.1.

○○○○

WIRELESS AND CABLE COMBINE.

At the time of going to press we understand that the Imperial Wireless and Cables Conference has decided to recommend the formation of a Corporation embracing all wireless and cable communications within the Empire.

The Government would be represented on the Corporation, which would include the Marconi associated companies, the Eastern Telegraph Company, the Pacific Cable Board, and the beam and

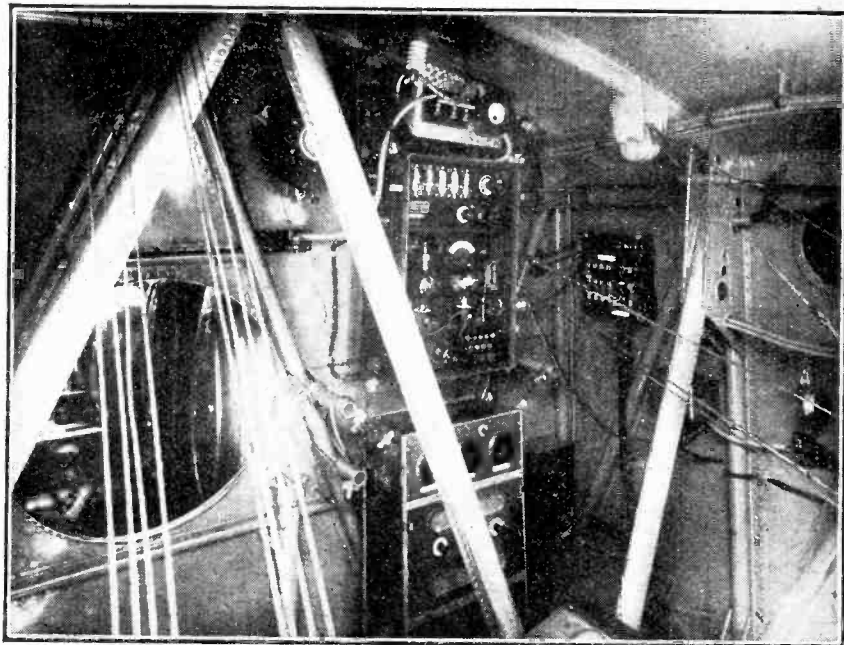

TRANSATLANTIC FLIGHT WIRELESS. A glimpse in the cockpit of Captain Courtney's Dornier Napier flying boat in which he is attempting a Transatlantic flight to and from America. The photograph, taken looking towards the rear of the machine, shows the Marconi AD 6 receiver and transmitter and the AD 16 direction finder.

cable services now operated by the Post Office.

Before it can be put into operation the scheme must, of course, receive Cabinet and Parliamentary sanction.

o o o o

ALLEGED "PIRATE" PROSECUTION FAILS.

An interesting case was heard at the Saxmundham police court recently, when a prosecution for using a wireless receiving set without a licence failed owing to the inability of the prosecutor to prove that the set was working properly.



CAPTAIN COURTNEY'S FLYING BOAT. The Dornier Napier photographed at Pisa. The call sign of the aeroplane is the same as its identification sign, G—CAJI.

The defendant, against whom the charge was brought at the instance of the Saxmundham postmaster, was absent, but in a letter to the magistrates he explained that he had been away three months at sea and had not used the receiver prior to going away. On his return the set was found to be out of order.

A representative of the post office stated that he had tested the set and admitted that he failed to pick up Davenport or any other station.

The magistrates decided to dismiss the case on a payment of Court fees of 4s., and refused to allow prosecuting witness's expenses.

o o o o

90-METRE TESTS FROM NAIROBI.

The station recently opened by the British East African Broadcasting Co. at Nairobi, Kenya Colony, will broadcast a series of experimental programmes extending over a period of about three months, beginning on Sunday next, July 15th. These transmissions will take place daily from 5.30 to 8.30 p.m. (B.S.T.). The station authorities are also hoping to arrange for an additional programme to be broadcast every Saturday, which will last until 10.30 p.m. (B.S.T.). The Nairobi station has an aerial power of approximately 4kW, and works on a wavelength of 90 metres. The call-sign is 7LO. Reports of reception in Britain will be welcomed by the station directors.

o o o o

NEW AUSTRALIAN BROADCASTING COMPANIES.

Two new broadcasting organisations have been formed in Australia. One is the Dominions Broadcasting Pty., Ltd., registered in Melbourne with a capital

of £200,000, to acquire the businesses carried on by the Broadcasting Co. of Australia Pty., Ltd., and the Associated Radio Co. of Australia, Ltd. The other is the New South Wales Broadcasting Co., Ltd. (Sydney), with a capital of £100,000. This concern will acquire the licences of 2FC and 2BL, of Broadcasters (Sydney), Ltd.

o o o o

AMERICAN AIRCRAFT ANTENNE.

A new form of aerial for aircraft has been developed by the U.S. Bureau of Standards to replace the trailing form

of antennæ which has been in use for many years. The new aerial consists of a metal rod extending vertically from the cockpit, having a total length of 10ft. Its chief advantage is that it practically eliminates the directional errors which were inseparable from the use of a suspended wire.

o o o o

CANADA-U.S. BEAM SERVICE.

The Canadian Government last week issued a licence to the Marconi Wireless Telegraph Co. of Canada for the establishment of a beam service between Montreal and New York. A contract has been entered into with the Radio Corporation of America.

o o o o

WIRELESS WITH THE WHALING FLEETS.

Wireless has been so valuable to whaling and sealing fleets that the Southern Whaling and Sealing Co., Ltd., are making important additions to the existing Marconi installations of their fleet for the coming season.

The "Southern Empress" is the new floating factory ship for the South Shetlands, and will be accompanied by three whale catchers. They will be equipped with telephone sets and direction finders, by means of which they will find their way back to the factory ship in fog or snowstorms, which normally cause considerable delay in whale catching.

The "Southern King" is attached to the South Georgia headquarters, carrying out the materials, stores, and men for the season, and returning with oil.

The "Southern King" and "Southern Empress" carry more equipment than the rest of the fleet because of their different

duties. In addition to the telephone equipment, short-wave transmitters are installed, which, it is anticipated, will keep these two ships in communication with British Post Office stations from the Antarctic, thus placing them in practically direct communication with the owners. Quenched spark transmitters for working with other ships and with local coastal stations during the voyage are installed, and also the latest type of wireless direction finders. Advantage has been taken of the high amplification factor of the new screened grid valves to incorporate two of them in the direction finder. The result has been to increase the selectivity and sensitivity of the amplifier in a remarkable manner. The fixed frame aerial system is used with this amplifier. They can be installed at any convenient place in the ship, and not necessarily in close proximity to each other.

WIRELESS AT WESTMINSTER.

From Our Parliamentary Correspondent.

Renewal Date of Wireless Licences.

In the House of Commons last week Major Carver enquired of the Postmaster-General how many broadcasting licences had now been issued, and whether, seeing that broadcasting licences now lasted for one year from the first day of the month in which they were issued, so as to facilitate the Post Office arrangements and for the public convenience, the renewal of broadcasting licences could be effected automatically on the first day of each year, as was the case with other licences.

Viscount Wolmer said that the number of wireless receiving licences in force was just over two and a half millions. There would be considerable congestion at the Post Offices if this large number of licences was renewable on the first of January, and he did not consider that it would be in the interest either of the public or of the Post Office to alter the present arrangement.

o o o o

Abolition of Spark Transmission.

In reply to a question by Mr. Hore-Belisha regarding the use of spark transmission, Lord Wolmer said that the International Radiotelegraph Regulations drawn up at the Washington Conference last year provided for a gradual reduction in the use of the spark system. Under these Regulations no new land stations might be established on the spark system, and the use of spark transmitters by land stations was to be discontinued entirely by the end of 1934. The Regulations permitted the use of spark transmitters on ships, although after the end of 1929 no new spark transmitter might be installed of higher power than 300 watts, and after the end of 1939 no spark transmitter of higher power than 300 watts might be used on a ship.

The new Regulations would be applied in this country, and a start had already been made in the work of converting the British coast stations from the spark system to a different system.

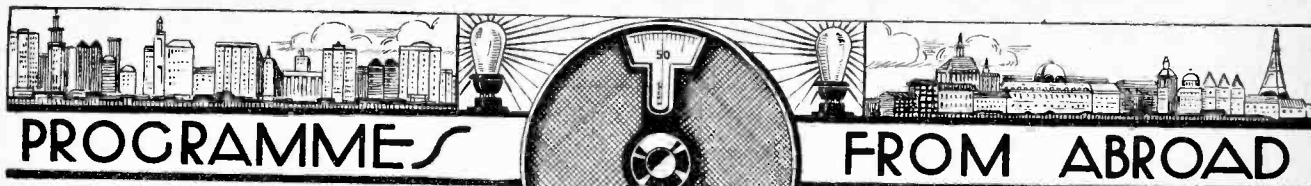

BARCELONA (Radio Barcelona). Call EAJI (344.8 metres); 1.5 kW.—6.0, Exchange Quotations. 6.10, Sextet Selections, Paso-doble, Serrano (Sentis); La-haut (Yvain), Waltz; Roses of the South (J. Strauss); Cancion canaria (Torroba), La noche de Reyes (Serrano). 9.0, Exchange Quotations and News. 9.5, Orchestral Concert: March, Good Luck (Woodhouse); El Barberillo de Lavapiés (Barbieri); Waltz: The Chocolate Soldier (Oscar Straus); Larghetto, Tendresse (Delmas); The Third Tango, Nocturne (Jordi); Serenata (Charpentier); Overture to "Flotte Bursche" (Suppe). 10.0, Exchange Quotations and Weather Report. 10.5, Programme relayed from Madrid, EAJI.

BERGEN (370.4 metres); 1.5 kW.—8.0, The Wireless Orchestra: Hungarian Rhapsody (Erichs); Serenade, Vision (Drdla); Auf echt Wiener-Manier-Vals (Fucik). 9.30, Soprano Solos by Mrs. Nancy Naess: Cavalleria Rusticana (Mascagni); La Tosca (Puccini); Aida (Verdi). 9.0, Trade Advertisement Union Programme. 9.30, Whistle Duets by Miss Ellen Schnitler and Tibor Ney. 10.0, Weather Report, News and Time Signal. 10.15, Dance Music from the Hotel Norge. 12.0 Midnight, Close Down.

BERLIN (Königswusterhausen) (1,250 metres); 40 kW.—12.0 Noon, Talk: Bohemia in Music and Prose. 3.0, Talk by B. K. Graef. 3.35, Weather Report and Exchange Quotations. 4.0, Shorthand Dictation by Fritz Westermann. 4.30, Talk, by T. Kotzur. 5.0, Programme from Hamburg. 6.0, Prof. Woldt, Talk: Mein Werk. 6.30, Elementary Spanish Lesson. 6.55, Dr. Hünc and Johann Strauss, Talk: The Comic Element in Piano-forte Music. 7.20, Prof. Kinde-Pouet, Talk: Goethe and Present Day Creative Art. 8.30, Programme from Voxhaus.

BERLIN (Voxhaus) (484 metres); 4 kW.—4.15, Sports Relay: Trials for the Olympic Games from the German Stadium, Berlin-Grunewald, followed by Light Music; Overture to "Der Vampyr" (Marschner); Waltz: Estudiantina (Waldteufel); Memories of Brahms (Morena); Barcarolle (Mascagni); Scherzo (de Teye); Two Waltzes, Op. 54 (Dvórák), News. 7.0, Dr. Max Apel, Talk: From the Life of the Great German Philosopher of the Nineteenth Century, Johann Friedrich Herbart. 7.30, Dr. Bölling, Talk: Progressive Tendencies of the League of Nations. 8.0, Dr. Kurt Richter, Talk: Travel Pictures of America. 8.30, "Halbzeit," Play (Bronnen and Braun), followed by News, Time Signal, Weather Report and Sports Notes. 10.30, Concert of Operetta Music: Selection from "Die Fledermaus" (Joh. Strauss); Soprano Solos: (a) Mein Herr Marquis, (b) Spiel' ich die Unschuld von Lande, (c) Ich lade gern mit Gäste ein; Waltz, Du und Du. Selection from "The Bird Fancier" (Zeller); Songs from "The Bird Fancier" (Zeller); Ich bin die Christel von der Post; Beschieden, mit verschämten Wangen; Als gelüht der Kirchenbaum; Melodienkranz.

BERN (411 metres); 1.5 kW.—8.0, Time Signal and Weather Report. 8.5, Programme from Vienna. 9.45, News and Weather Report. 10.0, The Bern Orchestra. 10.35, Dance Music. 12.0 Midnight (approx.), Close Down.

BRESLAU (322.6 metres); 4 kW.—6.15, Talk in Esperanto. 6.30, Programme from Königswusterhausen. 7.25, English Lesson. 7.50, Herr Lehmann, Talk: Germany and the other Peoples. 8.30, Variety Concert: Old Song (Kreisler); Lute Solos (Bellman): (a) Abendlied, (b) Frühstück im Grünen, (c) Ulla Winblad im Fischerdörfchen, (d) Überfahrt zum Tiergarten; Soprano Solos: Kirschblütenfest (Dicker); Lute Solos (Bellman): (a) Brantweinbrenner Lundholms Tod, (b) Im Krüge Thermopolium Boreale, (c) Vater Berg spielt Geige, (d) Vater Noah, (e) Am Mutter auf Tuppen; Pianoforte Solos: Old English Song, Cherry Ripe (Scott). 10.0, News, followed by Programme from Voxhaus. 12.0 Midnight (approx.), Close Down.

BRUNN (441.2 metres); 3 kW.—6.0, Time Signal and German Transmission. 6.25, Programme of Talks. 7.0, Concert of French Music; Overture to La Patrie (Bizet), Danse macabre (Saint-Saëns); Selection from Werther (Massenet), The Enchanted Forest (Pridy), Selection from the Works of Massenet; Prelude (Frank). 8.0, Drama by Clemenceau. 9.20, (approx.), Exhibition Programme. 10.0, Programme from Prague. 10.25, Exhibition Programme.

SATURDAY, JULY 14th.

All Times are reduced to British Summer Time and are p.m. except where otherwise stated.

BRUSSELS (508.5 metres); 1.5 kW.—5.0, Dance Music from the St. Sauveur Palais de Danse. 6.0, English Lessons. 6.45, Trio Concert: Marche militaire française (Saint-Saëns); Flute Solo: Pan et les oiseaux (Moquet), Barcarolle (des fresques (Gaubert), Petites musiques (Schnittt), Air de Ballet from Scenes pittoresques (Massenet); Cello Solo: Chanson villageoise (Lalo), The First Nocturne (Pierne), En Bateau (Debussy), Minuet (Debussy), Allegro for Clarinet (Rabaud), Pas des fleurs (Delibes). 7.30, Radio-Chronique. 8.15, Gramophone Selections. 8.30, Literary Selections. 8.50, Talk on Topical Events. 9.0, Concert relayed from the Ostend Kursaal, News. 10.30, (approx.), Close Down.

BUDAPEST (555.6 metres); 35 kW.—5.0, Literary Talk, by Prof. J. Méses. 5.45, Hungarian Songs by Fr. E. Komlossy, and Selection of Tzigane Music. 7.0, H. C. Tabory, Talk: What we saw in America. 7.45, Studio Performance of "Lily Barono," Operetta in Three Acts (Martos-Huszká). In the Intervals, Racing Results, Time Signal and News. 10.45, Dance Music from the Hotel Ritz.

COLOGNE (283 metres); 4 kW.—11.15 a.m., Programme in Celebration of the 700th Jubilee of the Town of Xanten, relayed from Xanten. 1.5, Orchestral Concert: Nibelungen-Marsch (Sonntag); Waltz: Sant und Seide (Ziehrer), Overture to "The Black Domino" (Auber), Melodies from "Hansel and Gretel" (Humperdinck); Bass Solos: (a) Die Mütter (Fritz Fleck), (b) Salome Suite (Arnold), Potpourri, (Ganne), Modern Ballet Suite (Hans Hermann), Extase (Hoppla); Wir taazen (Geisler). 2.30, Talk for Housewives. 4.0, Programme of Recitations. 4.30, Programme from Königswusterhausen. 5.0, Talk for Women. 5.30, See Langenberg. 7.20, Talk for Workers. 7.45, See Langenberg. 8.10, Programme from Dusseldorf (See Langenberg), followed by News, Sports Notes, Concert and Dance Music. 1.0 a.m. (approx.) (Sunday), Close Down.

CRACOW (566 metres); 1.5 kW.—6.0, Programme for Children. 7.0, Miscellaneous Items. 7.30, Agricultural Report. News. 7.50, Programme from Warsaw. 8.15, Programme from Warsaw. 10.30, Restaurant Concert. 11.30 (approx.), Close Down.

DUBLIN, Call 2RN (319.1 metres); 1.5 kW.—7.20, News, followed by "Stage Reminiscences." 7.45, Talk in Irish. 8.0, The Station Orchestra. 8.30, E. Denne (Contralto). 8.40, C. Chevis (Mandoline). 8.50, The Waverly Vocal Quartet. 9.20, E. Murnaghan (Soprano). 9.35, Community Players' Sketch. 10.3, The Station Orchestra. 10.30, News and Close Down.

FRANKFURT (423.6 metres); 4 kW.—6.15, Wireless Notes and Miscellaneous Announcements. 6.30, The Letter Box. 7.0, Lesson in Shorthand. 7.30, Talk: The cactus and similar plants. 8.0, Concert from Baden-Baden (See Stuttgart), followed by Programme from Voxhaus.

HAMBURG, Call HA (in Morse) (394.7 metres); 4 kW.—3.30, Book Review. 4.0, Labour Market Exchange Report. 4.15, Music Talk by Dr. W. Heinitz. 5.0, Programme from Königswusterhausen. 6.0, Variety Programme. 7.0, Legal Talk, by Dr. Walter Bogs. 7.30, Dora Moldehuke, Talk: Old Hamburg.

7.55, Weather Report. 8.0 (approx.), Programme from Stuttgart. 10.15 (approx.), News. 10.30 (approx.), Cabaret Concert.

HILVERSUM (1,071 metres); 5 kW.—11.40 a.m., News. 12.10, Concert of Trio Music. 1.40, Concert relayed from the Tuschinski Theatre, Amsterdam. 3.40, Royal Marine Band Concert. 5.40, Concert: Overture to The Bohemian Girl (Dalfé), Suite Miniature (Kargauoff), La gondola (Heinselt); Tenor Solos: (a) La coupe du roi de Thule (Diaz), (b) Lievelingskind (Andriessen), (c) Mijn hart is in Holland (Spool); Selection from Hérodiate (Massenet); Mattinata (Leoncavallo); Four Songs for Tenor; Selection of Waltzes (arr. O. Fetras); Finales. 7.25, News. 7.40, Concert and Talk arranged by the Workers' Radio Society. 10.10, Concert relayed from the Royal Cinema, Amsterdam. 11.15 (approx.), Close Down.

HUIZEN (340.9 metres); 4 kW. Transmits from 5.10 p.m. on 1,870 metres.—12.10, Concert of Trio Music. 5.10, Gramophone Selections. 7.25, Talk by Dr. Deckers, relayed from The Hague. 7.55, Concert by a Male Voice Choir, and M. H. Stroenen (Pianist).

JUAN-LES-PINS (Radio I.L.) (248 metres); 1.5 kW.—1.0, Orchestral Concert. 9.0, News and Weather Report. 9.5, Variety Concert. 10.0, Dance Music. 10.30 (approx.), Close Down.

KALUNDBORG (1,153 metres); 7 kW. Programme also for Copenhagen (337 metres)—7.30 a.m., Morning Gymnastics. 11.0 a.m., Weather Report (Kalundborg only). 3.0, Trio Concert: Military March (Schubert); Waltz, The Blue Danube (Strauss); Tambourin (Gossec); Air (Bach); Gavotte (Rameau); Violin Solo: Canzonetta (Henriques); Selection (Heise); Recitation by J. O. Boving Petersen; Polka: Brautschau Op. 417 (Strauss); Mattinata (Leoncavallo); Berceuse slave (Neruda); Waltz: Acceleration (Strauss); Selection from Nitouche (Hervé); Humoresque (Dvórák); Persian March (Strauss). 6.20, Capt. Kurt Koch, Talk: The White Swan's Song. 6.55, Weather Report (Kalundborg only). 7.0, News. Exchange Quotations and Time. 7.20, Programme Announcements. 7.30, Lieutenant John Foltmann, Talk: Transatlantic Flights. 8.0, Chimes from the Town Hall. 8.2, Programme for old people; Overture to A Sunday on Amager (Fröhlich); Hesperus Waltz (Lumbye); Melodies (Erich Bogh); Old Acquaintances (Larsen); Dream Pictures (Lumbye); Melodies (Erich Bogh); News. 9.15, "Many Years After," Play (Axel Steenbuch). 9.45, Concert of old dance music: Hungarian Hussars' March (Möller); Laura Polka (Nielsen); Näscheri (Ziehrer); Hofballtänze (Joh. Strauss); Ida Polka (Winther); Mazurka (Winther); Trippeltes (Nielsen); Methusalem Quadrille (Joh. Strauss); Bébé Polka (Lanciuu); Saturday Night (Mortensen); Waltz: Pesiher (Lanner); Gallop: Ormonde (Jespersen). 10.45, Dance Music. 12.0 Midnight, Chimes from the Town Hall. 12.15 a.m. (approx.) (Sunday), Close Down.

KATOWITZ (422 metres); 10 kW.—6.0, Programme for Children. 7.0, Miscellaneous News. 7.20, The Children's Letter Box. 7.50, Programme from Warsaw. 8.15, Programme from Warsaw. 10.0, Time Signal and News. 10.30, Dance Music.

KAUNAS (2,000 metres); 7 kW.—12.0 Noon, Chimes. 7.0, Concert of Gramophone Selections. 9.15, Concert, by the Fifth Infantry Regimental Band. 10.15, Dance Music.

LAHTI (1,522.8 metres); 35 kW.—5.0, Melodies from The Circus Princess (Kalmán), and Talk. 5.57, Time Signal, News and Weather Report. 6.15, Concert: March (Myddleton), Melodies from Rigoletto (Verdi); Waltz, Du und Du (J. Strauss); Finnish Songs (arr. Kauppi); Finnish Songs (Merikanto); Songs, Melodies from "Herbstmanöver" (Kalmán); Melodies from Lakmé (Delibes); Valse Barcarole (Waldteufel), Lichtertanz (Rubinstein); March (Oscheit). 8.45, News in Finnish and Swedish, and Restaurant Relay. 10.0 (approx.), Close Down.

LANGENBERG (468.8 metres); 20 kW.—Programme also for Aix-la-Chapelle (400 metres), Cologne (283 metres), and Münster (250 metres)—11.15 a.m., Programme in Celebration of the 700th Jubilee of the Town of Xanten, relayed from Xanten. 1.5 to 4.30,

Programmes from Abroad.—

Programme from Cologne. 4.30, Programme from Königswusterhausen. 5.0, Programme from Cologne. 5.30, Elementary English Lesson, relayed from Münster (250 metres). 6.0, Mandoline Concert, relayed from Dortmund; Overture to "Pique-Dame" (Suppé), Chanson triste (Tchaikovsky); Selections from "Märchenbilder" (Ritter); Waltz in E Minor (Althoff); Selection from "Don Carlos" (Verdi); Russian Folk-Dance, Die Knaben, Toreador et Andalouse (Rubinstein); March, Castaldo (Novacek). 6.50, Sports Relay from Dusseldorf. 7.20, Programme from Cologne. 7.45, Talk relayed from Münster: The Westphalian Peace and its historical significance. 8.10, "Hoppla, wir marsen," Revue (Reiss-Eibert) from Dusseldorf, followed by Programme from Cologne.

LEIPZIG (365.8 metres); 4 kW.—6.45, Talk: Legal Matters. 7.0, Talk: Postal Hints for Travellers. 7.30, Talk: Plant Life under the Seas. 8.0, Weather Report and Time Signal. 8.15, Concert of Operetta Music; Overture to Light Cavalry (Suppé); Songs, (a) Air from Prince Methusalem (Joh. Strauss); (b) Cousin Bobby (Müllcker); (c) Das süsse Mädel (Reichhardt); (d) Waltz Song from Unter der blühenden Linde (Gellert); Duets, (a) from Unter der blühenden Linde (Gellert); (b) from The Count of Luxembourg (Lehár); Melodies from "Schwarzwaldmädel" (Jessel); Songs, (a) Madame Sherry (Felix); (b) Waldmeister (Joh. Strauss); (c) Cigarette Song from Der Orlof (Granchstäedten); (d) Mein Herzensjunge (Kollo); Melodies from Eva (Lehár); Duets, (a) Der Liebe Augustin (Fall); (b) The Last Waltz (Oscar Strauss), Cavalier Waltz (Nedbal). 10.0, News and Sports Notes. 10.15, Programme from Voxhaus. 12.0 Midnight (approx.), Close Down.

LILLE Call PTT (264 metres); 0.5 kW.—12.30, Concert arranged by the Wireless Association of Northern France. 3.0, Culinary Talk by Mme. de Surgère, followed by "La Delaiscée," Comedy in one Act (Max Maurey). 7.0, Concert arranged by l'Echo du Nord. 8.30, Concert arranged by the Wireless Association of Northern France, News.

MADRID (Union Radio), Call EAJ 7 (375 metres); 3 kW.—7.0, Orchestral Selections, The Lions of Castile (Serrano), Marouf (Rabaud), El mal de amores (Serrano); in the interval, Items by Luis Medina. 8.0, Dance Music. 9.45, Market Prices. 10.0, Chinese and Exchange Quotations. 10.10 (approx.), "The Taming of the Shrew" Play (Shakespeare), adapted for broadcasting by Ruy de las Arcas, News. 12.0 Midnight, Dance Music. 12.30 a.m. (approx.), (Sunday), Close Down.

MILAN, Call IMI (526.3 metres); 7 kW.—8.35, Time Signal, followed by Talk: Verdi, with Musical Illustrations. 8.45, Variety Concert; Overture to "Prometheus" (Beethoven), Slegfried Idyll (Wagner); Selection from "The Magic Flute" (Mozart); Baritone Solo from "Faust" (Gounod); Violin Solos (Ravassenga), Selected Items; Selection from "Dinorah" (Meyerbeer). The Cricket Sings (Bill); Baritone Solos (Mazzaroli); Danse Macabre (Saint-Saëns), News. 11.0, Dance Music relayed from the Cova Restaurant, Milan. 11.30 (approx.), Close Down.

MOTALA (1,380 metres); 30 kW.—Programme also for Stockholm (454.5 metres), Göteborg (416.5 metres), Malmö (269.9 metres), Sundsvall (545.6 metres), Östersund (720 metres), and Boden (1,199 metres).—5.30, Concert of Light Music. 7.0, "The Golden Car" Play (Betzenich). 7.45, Talk: Topical Events. 8.0, S.O.S. Cabaret Concert; Text and Music by Sven Olof Sandberg, Introductory Talk, Adventure; Once in a thousand years; Lillian can sleep; Dialogue, When the lime trees bloom; Summer night; S.O.S. Waltz; Selection, An Adventure in Zanzibar; Sabbath Eve; Finale. 9.15, News and Weather Report. 11.30, Programme by Rolf's Dance Orchestra. 1.0 a.m. (approx.), (Monday), Close Down.

NAPLES, Call INA (333.3 metres); 1.5 kW.—8.40, Time Signal, News and Harbour Notes. 8.50, Concert of Operetta Music, Bambolina (Ranzato); Duet from "Addio Giovinezza" (Mattioli), Rose, Rose, Spinelli (Ranzato); Duet from "La Bayadère" (Kalman); Selection from "The Geisha" (Jones); Finale from "The Grenadiers" (Valente); Selection from "Eva" (Lehár); Selection from "Katja the Dancer" (Gilbert), La Danzatrice Scalza" (Albini); Duet (Ranzato), Romance from "The Count of Luxembourg" (Lehár); Selection from "Cin Cin Là" (Ranzato); Duet from "The Count of Luxembourg" (Lehár). 10.55, Calendar and Programme Announcements, and Close Down.

OSLO (461.5 metres); 1.5 kW.—Programme relayed by Hamar (555.6 metres), Fredriksstad (434.8 metres), Notodden (411 metres), Porsgrund (500 metres), and Rjukan (418 metres). 7.45, Weather

Saturday, July 14th.

Report, News, Market Prices, and Time Signal. 8.2, Song Recital: Songs (Grieg), (a) Margaret's Cradle Song; (b) Mødersorg; (c) Priula Veris. Folk Songs of Normandy, Plegie (Massenet), Rosenkransen (Nevin). 8.30, Orchestral Concert: Overture to William Tell (Rossini), Selection from Fra Diavolo (Auber), Indian Lament (Dvůřák). 9.0, Variety Selections. 9.30, News and Sports Notes. 9.45, Talk: See and Hear. 10.0, Orchestral Concert. Meditation (Glazounov), Liebeslied (Kreisler), Hungarian Dance (Brahms), Romance (Rubinstein), Estudiantina (Waldteufel). 10.30, Dance Music relayed from the Grand Hotel. 12.0 Midnight (approx.) Close Down.

PARIS (Ecole Supérieure), Call FPIIT (458 metres); 0.5 kW.—Programme relayed at intervals by the following stations: Bordeaux PTT (275 metres), Eiffel Tower (2,650 metres), Grenoble (416 metres), Lille PTT (264 metres), Limoges (285 metres), Lyon PTT (476 metres), Marseilles (303 metres), Rennes (280 metres), and Toulouse PTT (260 metres).—8.30, Results from the Journal Paris Sport. 9.0, Concert, followed by Dance Music from the Coliseum de Paris.

PARIS (Eiffel Tower), Call FL (2,650 metres); 5 kW.—6.45, Le Journal Parle. 8.10, Weather Report. 8.30, Concert: Mlle. Suzanne Guellier, Song, La Marseillaise (Rouget de Lisle); M. Dany Champeau, Song, Le Chant du départ (Méhul); Pianoforte Solos: (a) Alsatian Scenes (Massenet), (b) Alsatian Dances (Lévaillé), (c) Danses de chez nous (Jacquet). 9.30, Educational Programme, Talks: (a) Legal Protection for the Family, by M. Michel Faguert; (b) The Origin of Religions, by M. Paul Perrin; and (c) Political Economy.

PARIS (Radio-Paris), Call CFR (1,750 metres); 6 kW.—12.30, "Columbia" Gramophone Concert: Selections from Lohengrin (Wagner); Symphonic Poem, Don Juan (Strauss); Song from Lakmé (Delibes); Selection from Cyrano de Bergerac (Rostand); Krentzer Sonata, Op. 47 (Beethoven); by Mr. Albert Sammons (Violinist) and Mr. William Murdoch (Pianist); "The Man I Love" from "Will Whispers" (Gershwin); by Leyton and Johnstone; Swanee Shore (Hess and Johnstone), by Leyton and Johnstone; I Scream You Scream, We All Scream in Ice Cream; The Kit Kat Band, Yale Blues, There's a Ricketty-Racketty Shack, News. 1.50, Exchange Quotations and Religious Notes. 3.45, Dance Music, News. 7.30, Pianoforte Interlude. 8.0, Agricultural Report. 8.15, Exchange Quotations and News. 8.30, Concert: "Le Fiancé de Margot," Operetta (Planquette), followed by Concert; Marching Songs: (a) Fanfan la Tulipe, (b) Chant du départ, (c) Chant des grondins, The Marseillaise, Dance Music, News.

PITTSBURGH, Call KDKA (63 and 27 metres); 25 kW.—11.0, Time Signal and Baseball Scores. 11.25, KDKA Theatrical Calendar and Cambria Fair News. 11.30, The Westinghouse Band from the William Penn Hotel. 11.55, Baseball Announcements. 12.0 Midnight, Time Signal and The Westinghouse Band (continued). 1.0 a.m. (Sunday), Programme to be announced. 1.45 to 2.30 a.m., New York Relay. 2.0 a.m., Lew White Organ Recital and Longine Time. 2.30 a.m., Keystone Duo with Balladeers Programme. 4.0 a.m., Weather Report, Telechron Time and Baseball Announcements. 4.15 a.m. (approx.), Close Down.

POSEN (344.8 metres); 1.5 kW.—6.0, Violin Recital. 7.0, Talk: The Scouts. 7.15, French Lesson. 7.35, Talk: Journalism. 8.0, Finance Report. 8.30, Programme from Warsaw. 10.0, Time Signal, News, Weather Report and Miscellaneous Items. 10.40, Dance Music from the Carlton Restaurant. 12.0 Midnight, Maison Philips Orchestral Concert with Violin Solos. 2.0 a.m. (approx.) (Sunday), Close Down.

PRAGUE (348.9 metres); 5 kW.—5.0, Radio Cabaret. 6.0, German Transmission. 6.25, Agricultural Report. 6.35, Talk for Workers. 7.15, Popular Programme. 8.40, Dramatic Selections. 9.0 Concert of French Opera Selections: Overture to Medea (Cherubini); Fra Diavolo (Auber); Selection from Faust (Gounod); The Pearl Fishers (Bizet); Selections from Hérodiade (Massenet). 10.0, Time Signal, News, Orchestral Selections, and Programme from Brunn.

ROME, Call IRO (450 metres); 3 kW.—1.30, Opening Signal. 1.32, Trio Concert. 2.30, News. 4.40, Opening Signal and News. 4.50, Wireless Talk. 5.15, Agricultural Report. 5.28, Vocal and Instrumental Concert: Pianoforte Solos: (a) Sonata No. 18 (Scarlati), (b) Liebeslied (Liszt); Baritone Solos: Two

Bulgarian Songs; Soprano Solos: (a) Spirite pur, spirite (Donaudy), (b) The Daughter of Carliz (Massenet); Pianoforte Solo: The Dancer of Jodpur (Gasco); Ciga (Martucci); Baritone Solos: Two Bulgarian Songs; Soprano Solos: (a) Mamon Lescaut (Puccini), (b) La Perla (Bianchini). 8.15, Sporting Signal and Government Report. 8.35, Sports Notes, News and Weather Report. 8.58, Time Signal. 9.0, Orchestral Selection, Overture to Le Roi d'Ys (Lalo). 9.15, (approx.), "The Prodigal Son," Opera (Debussy), and "Sanson and Delilah," Opera (Saint-Saëns). In the Interval, Review of Art and Literature, by Lucia d'Ambrà. 11.5, News. 11.15, Close Down.

SCHENECTADY, Call 2XAD and 2XAF (21.96 and 31.4 metres); 30 kW.—11.25, Baseball Announcements. 11.30, Dinner Music Programme. 12.25 a.m. (Sunday), Baseball Scores. 12.30 to 3.20 a.m., Programme relayed from New York. 12.30 a.m., Statler's Pennsylvania. 1.0 a.m., "Bonnie Laddies." 1.30 a.m., Concert by the Philharmonic Orchestra. 3.20 a.m., Organ Recital from Rochester. 4.0 a.m., Dance Music. 5.0 a.m., (approx.), Close Down.

STAMBOUL (1,200 metres); 5 kW.—4.30, Orchestral Concert. 5.30, Market Prices and Exchange Quotations. 6.15, Concert of Turkish Music. 8.30, Weather Report and Time Signal. 8.40, Concert. 10.0, News and Close Down.

STUTTGART (379.7 metres); 4 kW.—6.0, Time Signal, Weather Report, and Report of the South-West German Labour Centre. 6.15, Sports Talk relayed from Freiburg (577 metres). 6.45, Concert of Sacred Alsatian Music, Introductory Talk. Children's Choir: (a) Es kommt ein Schiff, (b) Es steht ein Lind im Himmelreich, (c) Ich wollt' dass ich daheim wäre; Haec est Dies, for one voice and organ (Boeld-decker); Chorale: (a) O Sankt Odilia, (b) O ihr edle Himmelsknaben; Cantata: Verbig nicht deine eillen Strahlen (Frauenholz); Jehova (Gerold). 8.0, Chamber Music from Baden-Baden, Organ Suite (Pepping); Cantata: Reisebriefe eines Artisten (Roters); Music for organ (Jarneck); Chamber Oratorio, Wandlungen (Hauer), followed by Cabaret Concert; Achtung es wird gedreht (Strassmann); Die Welt ist wie a Narennhaus (Evsler); Foxtro Macabre (Holländer); Berlin Carnival (Weinert); Songs At 12, in the middle of the night (Hauptmann); Tango, Kiss Me! (Steffan); Die Eva war a Weinerin (Kratzky); Sonja, Songs: Nigger girl (Nelson); Musical Mathilde, Egyptian Ballad, In der Schweiz und in Tirol (Profes). News, followed by Concert and Dance Music from the Café-Restaurant Wilhelmshaus.

TOULOUSE (Radiophonie du Midi) (391 metres); 3 kW.—12.30, Orchestral Concert. 8.0, Time Signal, News and Exchange Quotations. 8.30, Concert: Pianoforte Solo, Hungarian Rhapsody, No. 12 (Liszt); Trio Selections: (a) Ave Maria (Schubert), (b) Scherzo in B Flat Major (Schubert); 'Cello Solos: (a) Allegro appassionata (Saint-Saëns), (b) Allegro of the 6th Sonata (Boccherini); Pianoforte Solo: Mazurka in B. Major (Chopin); Waltz in A Flat (Chopin). 9.0, Concert: Selection from Fortunio (Messager); 'Cello and Pianoforte Duet: Le Cygne (Saint-Saëns); Selection from The Merry Widow (Lehár), Sonnet (d'Arvers); Parody, Arvers' Sonnet (Donnay); Selection from a Waltz Dream (Oscar Strauss); Algiers at night (Terrier); Tradimento (Bonincontro); L'Amour toujours l'amour (Friml); Selection from Rigoletto (Verdi); Le Châlet (Adam); Le Cor (Flegier); Rip (Planquette); Indian Song from Rose-Marie (Friml); Accordion Selections, Military Music. 11.0, North African News.

VIENNA (577 and 517.2 metres); 1.5 and 5 kW.—6.20, Concert: Wiegenlied (Scott), Im der Fremde (Taubert), Das Rosenband (Schubert); Violin Solos, (a) Sérénade mélancolique (Tchaikovsky); (b) Chanson arabe (Krimsky-Korsakoff); Selections, (Löwe), (a) Landgraf Philipp der Grossmütige, (b) Der heilige Franziscus; (c) Prince Eugen, The Doll's Air from "The Tales of Hoffman" (Offenbach), Air from "Mignon" (Thomas); Pianoforte Solos, (a) Albumblatt (Mars); (b) Lied ohne Worte (Schmidt); (c) Skizze (Gal); (d) Jongleur (Toch). 7.20, Sonata for 'Cello in D Major (Rubinstein). 8.5, Play in three Acts (Wheatley), followed by Dance Music.

WARSAW (1,111 metres); 10 kW.—7.50, Dr. Morawsky, Talk: France and Poland in History. 8.15, Concert in Celebration of the French National Festival, Orchestral Selections, (a) The Marseillaise; (b) Overture to "Mignon" (Thomas); Soprano Solos, Air from Act I of "Lakmé" (Delibes); (b) Air from "Carmen" (Bizet), Orchestral Selection, Suite from "Roma" (Bizet); Soprano Solos, (a) O, si les fleurs (Massenet); (b) Après un rêve (Fauré); 'Cello Solo, Concerto (Saint-Saëns), Overture to "Carnaval romain" (Berlioz); Selection from "L'Aiglon" (Rostand, dramatised by A. Wiegierski); News in French in the Interval. 10.30, Dance Music from the Oaza Restaurant. 11.30 (approx.), Close Down.

SUNDAY, JULY 15th.

All Times are reduced to British Summer Time and are p.m. except where otherwise stated.

Programmes from Abroad.—

BARCELONA (Radio Barcelona), Call EAJr (344.8 metres); 1.5 kW.—12.0 Noon, Chimes from the Barcelona Cathedral, Local Weather Report, and Weather Forecast for Europe. 1.30, Iberia Instrumental Trio and Gramophone Record Selections. 2.45 to 9.0, Interval. 9.0, Sports Notes, Exchange Quotations and Market Prices. 9.15, Selections by the Station Orchestra. 9.30, Talks, followed by the Station Orchestra. 10.0, Chimes from the Barcelona Cathedral. 10.10, Concert of Soprano Songs and Violin Solos by Maria Teresa Planas and Senor Jarque, and Selections by the Station Orchestra.

BASLE (1,000 metres); 1.5 kW.—8.0 (approx.), Relay of Programme from Bern Station. 10.0, News Bulletin and Weather Report.

BERGEN (370.4 metres); 1.5 kW.—10.30 a.m., Divine Service relayed from a Church. Address. 12.30, Weather Forecast, News Bulletin, etc. 7.30 (approx.), Orchestral Selections. 9.0, Talk, followed by Weather Forecast, News Bulletin and Time Signal, with Musical Selections and Dance Music. 12.0 Midnight, Close Down.

BERLIN (Königswusterhausen) (1,250 metres); 40 kW.—6.30 a.m., Early Morning Orchestral Recital relayed from Voxhaus. 9.0 a.m., Sacred Instrumental and Choral Concert relayed from Voxhaus. 11.30 a.m., Open Air Concert relayed from Voxhaus. 2.0, Children's Programme relayed from Voxhaus. 3.30, Agricultural Programme relayed from Voxhaus. 6.30, Programme of Talks. 7.30 (approx.), Programme relayed from Voxhaus.

BERLIN (Voxhaus) (484 metres); 4 kW.—6.30 to 8.0 a.m., Early Morning Orchestral Recital. 9.0 a.m., Instrumental and Choral Concert of Sacred Music, followed by Chimes from the Berlin Cathedral. 11.30 to 12.50, Orchestral Concert. 2.0, Musical Programme for Children. 3.0, Lesson in Shorthand by Professor Amsel and Fritz Westermann. 3.30 to 3.55, Programme of Agricultural Talks, followed by Musical Selections. 7.0, Journalism Talk, followed by Popular Programme. 10.30, Dance Music Programme. 12.30 a.m. (approx.) (Monday), Close Down.

BERN (411 metres); 1.5 kW.—10.0 a.m., Relay of a Protestant Divine Service, with religious address. 1.3, Time Signal and Weather Forecast. 1.5, Selections by a Swiss National Orchestra. 3.30, Orchestral Selections. 5.35 to 8.0, Interval. 8.0, Time Signal and Weather Forecast followed by Harp Trio Music. 9.45, Sports Notes, News Bulletin, and Weather Report. 10.0, Orchestral Selections. 10.35 (approx.), Close Down.

BRESLAU (322.6 metres); 4 kW.—8.45 a.m., Relay of Chimes from Christ Church, Breslau. 11.0 a.m., Evangelical Morning Recital. 12.0 Noon, Musical Programme. 2.0, Guessing Competition. 2.10, Agricultural Talk. 2.35, Chess Lesson by Adolf Kramer. 3.0, Fairy Tale Recital by Friedrich Reinecke. 3.30, English Reading by Douglas Yates from "The Aran Islands," by John M. Synge. 4.0, Running Commentary on the German Light Athletic Championship relayed from Düsseldorf (Part I), followed by Talk. 5.0, German Light Athletic Championship Relay (Part II). 5.30, Orchestral Concert. 6.45, Weather Forecast. 6.50, Programme of Talks. 8.30, Musical Programme. 10.0, News Bulletin. 10.30, Dance Music Programme relayed from Berlin. 12.0 Midnight (approx.), Close Down.

BRÜNN (441.2 metres); 3 kW.—9.30 a.m., Agricultural Report. 10.0 a.m., Musical Selections. 12.0 Noon, Orchestral Concert. 4.0, Popular Concert. 5.30, Transmission for Workers relayed from Prague. 6.0, German Transmission. 7.0, Instrumental Music. 10.0, Time Signal and News Bulletin relayed from Prague. 10.20, Orchestral Music. 11.0 (approx.), Close Down.

BRUSSELS (508.5 metres); 1.5 kW.—5.0, Outside Relay of Dance Music. 6.0, Programme for Children by the Clowns Bonzo and Sylvia of the Théâtre des Enfants in Brussels. 6.30, Instrumental Concert. 7.30, Le Radio-Chronique—Journal Parlé of Radio-Belgique. Three Short Topical Talks. 8.15, Instrumental Music followed by News Bulletin. 10.30 (approx.), Close Down.

BUDAPEST (555.6 metres); 35 kW.—9.0 a.m., News Bulletin and Beauty Hints for Women. 10.0 a.m., Divine Service Relay. 12.0 Noon (approx.), Time Signal, Weather Forecast and Concert Programme. 3.30, Agricultural Talk. 4.0, Musical Programme. In the Interval, Time Signal and Weather Forecast. 6.30 (approx.), Talk and Sports Notes, followed by Popular Programme. 9.50, Time Signal and Sports Notes, followed by Concert of Programme Music. 12.0 Midnight (approx.), Close Down.

COLOGNE (283 metres); 4 kW.—Programme also for Langenberg (468.8 metres), Aix-la-Chapelle (400 metres), and Münster (250 metres).—9.0 to 10.0 a.m., Evangelical Morning Recital. 4.0 to 4.15, Special Relay from the Rheinstadion in Düsseldorf of a Running Commentary on the German Light Athletics Championship. 5.0 to 5.30, Continuation of German Light Athletics Championship Relay. 7.30 (approx.), Programme for Workers. 8.0, Programme of Music, followed by News Bulletin, Sports Notes and Commerce Report, and Orchestral Selections. 11.30 (approx.), Close Down.

CORK, Call 6 CK (400 metres); 1.5 kW.—8.30 to 11.0, Concert by the St. Vincent's Convent School Choir and Orchestra with Baritone and Violin Solos in the Intervals. 11.0, National Anthem. 11.15 (approx.), Close Down.

CRACOW (586 metres), 1.5 kW.—10.15 to 11.45 a.m., Relay of Divine Service from the Cathedral in Posen. 12.0 Noon, Fanfare from the Tower of the Church of Notre Dame in Cracow, Time Signal and Weather Forecast. 4.0, Topical Agricultural Talk, Report for Farmers and Weekly Agricultural Notes by Dr. St. Wasniewski. 5.0, Programme relayed from Warsaw. 6.30, Variety Selections. 7.10 (approx.), Literary Programme, Talk. 8.0, Fanfare from the Church of Notre Dame, followed by Sports Notes. 8.30, Concert of Violin, Zither, Pianoforte and Vocal Music. 10.0, Programme relayed from Warsaw. 10.30, Orchestral Concert. 11.30 (approx.), Close Down.

DUBLIN, Call 2 RN (319.1 metres); 1.5 kW.—8.30, to 11.0, Orchestral, Choral and Soloist Concert relayed from the Cork Station, Nora Ni Mhathaghambha-Amhrain. 11.0, National Anthem. 11.15 (approx.), Close Down.

FRANKFURT (428.6 metres); 4 kW.—8.0 a.m. Morning Concert. 11.0 a.m. (approx.), Talk for Parents, under the direction of Dr. Flesch and Herr K. Wehrhan. 6.0, Popular Educational Talk. 8.0 (approx.), Musical Programme, followed by Dance Music relayed from Berlin. 12.30 a.m. (approx.), (Monday), Close Down.

HAMBURG, Call HA (in Morse), (394.7 metres); 4 kW.—Programme relayed by Hanover (297 metres), Bremen (272.7 metres), and Kiel (254.2 metres).—6.30 a.m., Early Morning Recital relayed from Voxhaus. 8.25 a.m., Time Signal. 8.30, Weather Report and News Bulletin. 8.50 a.m., Commerce Notes and Programme Announcements. 9.15 a.m., Sacred Morning Concert, with Religious Address. 10.55 a.m., (for Kiel only), Relay of the Divine Service from the University Church in Kiel. 11.0 a.m. (for Hamburg Hanover and Bremen only), Talk on Trade Secrets in the Technical World, by Dr. Funk. 12.55, Nauen International Time Signal. 1.0 (for Hamburg and Kiel only), Orchestral Concert. 1.0 (for Bremen only), Gramophone Record Selections. 2.0, Programme for Children. 3.0, Instrumental Concert. 7.40, Sports Notes and Weather Forecast. 8.0, Musical Programme, followed by News Bulletin and Concert from the Café Walfloh (for Hamburg and Kiel only); for Hanover and Bremen, Concert relayed from the Café Continental in Hanover. 11.0 (approx.), Close Down.

HILVERSUM (1,071 metres); 5 kW.—12.40 (approx.), Instrumental Trio Concert. 2.40, Orchestral and Soloist Concert relayed from the Kurhaus in Scheveningen: the Residence Orchestra conducted by Ignaz Neumark. 5.40, (approx.) Selections, by the Station Orchestra, conducted by Nico Treep. 7.40 Time Signal, Weather Forecast and News Bulletin. 7.55, Musical Programme Finlandia Suite (Sibelius). 10.30 (approx.), Close Down.

HUIZEN (340.9 metres); 4 kW. Programme on 1,870 metres after 5.40 p.m.—12.10, Concert by the Winkels Instrumental Trio of Amsterdam. 1.10, Literary Talk, followed by Relay of a Concert. 5.15 (approx.), Relay of a Church Service. 7.10, Programme of Talks, followed by Musical Selections. 10.25, Epilogue by the Station Choir.

JUAN-LES-PINS (Radio L.L.), (246 metres); 1.5 kW.—1.0 to 2.0, Orchestral Concert; Talk for Children by Monsieur Marcel Laporte (Radiolo). 9.0 to 10.0, News Bulletin, Weather Forecast and Orchestral

Concert. 10.0, Dance Music Programme by the Dance Orchestra of the Juan-les-Pins Municipal Casino. 10.30 (approx.), Close Down.

KALUNDBORG (1,153 metres); 7 kW.—Programme also for Copenhagen (337 metres). 10.0 a.m., Divine Service and Sermon relayed from a Church. 11.30 a.m. (for Kalundborg only), Weather Report. 11.40 a.m. to 2.0, Interval. 2.0, Divine Service and Sermon relayed from a Church. 3.15, Orchestral Concert. 5.30 to 6.50, Interval. 6.50, Weather Report (for Kalundborg only). 7.0, News Bulletin. 7.15, Time Signal. 7.30, Talk. 8.0, Relay of Chimes from the Town Hall in Copenhagen. 8.5, "From the Animal Kingdom," a Concert of Music and Songs relating to Animals, Recital in Danish of Cyril Scott's Impressions of Kipling's "Jungle Books": (a) The Jungle, (b) Dawn, (c) Rikki-Tikki-Tavi and the Snake, (d) Morning Song in the Jungle, (e) Dance of the Elephants. Followed by Last News Bulletin. 9.45, Instrumental Concert. 10.45, Dance Music Programme with Chimes from the Town Hall at 12 Midnight, in the interval. 12.30 a.m. (approx.) (Monday), Close Down.

KATOWITZ (422 metres); 10 kW.—10.15 a.m., Divine Service relayed from a Church. 12 Noon, Time Signal and News Bulletin. 4.0, Religious Address. 4.20, Talk: The Silesian Gardener, by W. Wlosik. 4.40, Talk, followed by Music. 6.30, Various Announcements. 8.15, Relay from one of the Polish Stations. 10.0, Time Signal and News Bulletin. 10.30, Programme of Dance Music. 11.30 (approx.), Close Down.

KAUNAS (2,000 metres); 7 kW.—12.0 Noon, Chimes. 12.5, Sacred Music. 5.0, Agricultural Bulletin. 6.0, Musical Selections. 6.30 Sports Talk. 7.15, Selections of Music. 7.30, Health Talk. 8.30, (approx.), Time, Weather and News. 9.0, Concert.

KÖNIGSBERG (329.7 metres); 4 kW. Programme relayed by Danzig on 272.7 metres. 9.0 a.m., Sacred Vocal Music, Organ Selections and Religious Address. 11.0 a.m. (for Königsberg only), Weather Report. 11.30 a.m., Orchestral Concert. 12.55, Nauen International Time Signal, followed by Weather Report. 3.30 to 7.0, Programme of Talks and Music. 7.0, Reading by Richard Knorr of the Danzig Municipal Theatre of "Die Güte" and "Der Becher"; Two Short Stories by Wolfgang Federar. 8.0, Light Popular Programme. 10.0, Weather Report, News Bulletin and Sports Notes, followed by Dance Music Programme. 12.30 a.m. (approx.) (Sunday), Close Down.

LAHTI (1,522.8 metres); 35 kW.—Programme also for Helsingfors (375 metres).—9.0 a.m., Divine Service Relay, in Finnish. 10.50 a.m. Orchestral and Vocal Concert. 11.50 a.m., Weather Forecast and News Bulletin. 5.0, Talk and Instrumental Music. 5.57, Time Signal, Weather Report and Press News. 6.15, Orchestral Concert. 7.30, Variety Concert, Songs, with Vases and Popular Marches under the direction of Erkki Linko. 8.45, News in Finnish and Swedish. 9.15, Restaurant Concert Relay. 10.0 (approx.), Close Down.

LANGENBERG (468.8 metres); 20 kW.—Programme also for Aix-la-Chapelle (400 metres), Cologne (283 metres), and Münster (250 metres). 9.0 to 10.0 a.m., Evangelical Morning Recital relayed from Cologne. 4.0 to 4.15 and 5.0 to 5.30, Relay of a Running Commentary on the German Light Athletics Championship from the Rheinstadion in Düsseldorf. 7.30 (approx.), Programme for Workers, from Cologne. 8.0, Musical Programme, News Bulletin, Sports Notes, Commerce Report and Orchestral Selections. 11.30 (approx.), Close Down.

LAUSANNE (680 metres); 1.5 kW.—2.0 (approx.), Song Festival Relay. 8.30, Sports Notes. 8.40, Relay of Protestant Service, followed by Musical Selections.

LEIPZIG (365.8 metres); 4 kW.—8.30 a.m., Organ Recital relayed from the Leipzig University Church. 9.0 a.m., Concert of Vocal and Instrumental Music. 11.0 to 12.0 Noon, Relay of a Concert. 12.0 to 3.0, Programme of Talks. 3.0, Concert by the Dresden Wireless Orchestra under the Direction of Gustave Agunte, relayed from the Jahresschau in Dresden. 5.0, Concert of Choral Music by the Leipzig and District Association for the Education of the Blind. The Blue Danube, by Johann Strauss, arranged for Mixed Choir with Pianoforte Accompaniment by F. Th. Crusch. 6.30, Sports, followed by Popular Programme. 10.0, Sports Notes. 10.30, Dance Music Programme relayed from Berlin. 12.30 a.m. (approx.) (Monday), Close Down.

LILLE, Call PTT (264 metres); 0.5 kW.—12.30, Concert of Orchestral Music organised by the Association de Radiophonie du Nord de la France under

Programmes from Abroad.—

the Auspices of the Radio-Club de Lille. 1.35, Market Prices of Motor Oils followed by Programme of Talks and Music. 9.0, Special Relay of the Grand Carnival organised by the Municipal Authorities of the Town of Roubaix in Celebration of the French National Festival, relayed from Roubaix. Programme of Bass, Baritone and Pianoforte Solos with the Ballet from Goumou's "Faust," performed by the Maurice Leclercq Ballet, accompanied by the Grande Harmonie Municipale.

LYONS (Radio-Lyon) (291 metres); 1.5 kW.—11.0 a.m., Orchestral Selections. 11.30 a.m., Concert of Sacred Music. 7.30, News Bulletin, Weather Report, Topical Talk, followed by Sunday Sports. Talk by M. Paul Garcin, Talk on Agricultural Questions. 8.15, Concert: Part I., Selections of French Music; Part II., Dance Music Selections. 10.30 (approx.), Close Down.

MADRID (Union Radio), Call EAJ7 (375 metres); 3 kW.—11.30 a.m., Municipal Band Concert relayed from the Parque del Retiro, Madrid. 2.0, Selections by the Artys Orchestra. 3.0, Relay of Concert by the Hotel Nacional Orchestra. 3.30 to 7.0, Interval. 7.0, Children's Corner, Kiki and his Friends, Musical Selections. 8.0 to 8.30, Dance Music followed by the Artys Orchestra. 10.0, Chimes and Time Signal followed by Vocal and Instrumental Concert. 12.0 Midnight, Dance Music Programme. 12.30 a.m. (approx.) (Monday), Close Down.

MILAN Call 1 MI (526.3 metres); 7 kW.—10.30 a.m., Vocal and Instrumental Sacred Music. 12.30 to 1.30, Selections by the Station Quartet. 3.30, Opening Signal. 3.32, Concert of Songs and Quintet Selections. 4.45, Programme for Children. 5.15, Programme of Dance Music played by the Jazz Band of the Restaurant Cova in Milan. 6.15 to 8.25, Interval. 8.25, Opening Signal followed by Talks. 8.35, Time Signal followed by History Talk. 9.0, "The Secret Marriage"—Opera (Cinrossa). During the intervals, Sports Notes and News Bulletin. 11.45 (approx.), Close Down.

MOTALA (1,380 metres); 30 kW.—Programme also for Stockholm (451.5 metres), Göteborg (416.5 metres), Malmö (269.9 metres), and Sundsvall (345.6 metres).—11.0 a.m., Divine Service and Sermon relayed from a Church. 12.35, Weather Forecast. 12.55, Time Signal. 6.0, Divine Service relayed from a Church. 7.0 (approx.), Concert 7.30—Opening of the Thirteenth Temperance Congress, followed by Musical Selections. In the interval at 9.15, News Bulletin and Weather Report. 11.0 (approx.), Close Down.

MUNICH (535.7 metres); 4 kW.—Programme relayed by Augsburg (566 metres), Kaiserlautern (204.1 metres), and Nuremberg (211.9 metres).—11.0 a.m., Relay of Chimes from the Town Hall in Munich. 1.10, Programme of Talks and Music. 8.0, "Eva," Operetta in three Acts. Text by M. Willner and Robert Bodansky, Music by Franz Lehár, followed by Last News Bulletin and Concert Relay.

NAIROBI, Kenya Colony, Call 7LO (90 metres); 4 kW.—5.30 to 8.30, Programme for Testing Purposes.

NAPLES, Call INA (333.3 metres); 1.5 kW.—10.0 a.m., Recital of Sacred Music. 4.45, Weather Report and Programme for Children. 5.0, Vocal and Instrumental Concert. 5.30, Time Signal. 8.20, Wireless Reports. 8.40, Time Signal, followed by Report of the Harbour Authorities of Naples. 8.50, Vocal and Instrumental Concert with Elvira Alfano (Soprano), and Raff. Alicino (Baritone). 10.0, Sports Notes. 10.55, Calendar, followed by Programme Announcements for the following day. 11.0 (approx.), Close Down.

OSLO (461.5 metres); 1.5 kW.—Programme relayed by Fredrikstad (431.8 metres), Hamar (555.6 metres), Notodden (411 metres), Porsgrund (509 metres), and Bjøkan (148 metres). 10.20 a.m. (approx.), Chimes followed by Divine Service Relay. 7.45, News Bulletin. 8.0, Time Signal and Musical Selections. 9.45 (approx.), News Bulletin and Topical Talk. 10.30 (approx.), Dance Music relayed from the Hotel Bristol, Oslo. 12 Midnight (approx.), Close Down.

PARIS (Ecole Supérieure), Call FTTT (458 metres); 0.5 kW.—Programme relayed at intervals by the following Stations: Bordeaux PTT (275 metres), Eiffel Tower (2,650 metres), Grenoble (416 metres), Lille PTT (261 metres), Limoges (285 metres), Lyons PTT (176 metres), Marseilles (303 metres), Rennes (280 metres), and Toulouse PTT (260 metres). 8.0 a.m., Time Signal and First News Bulletin. 10.25 a.m., International Time Signal and Weather Forecast. 1.30 Light Orchestral Concert arranged by L'Association Générale des Auditeurs de I.S.F. 6.0, Le Radio-Journal de France, News Bulletin.

Sunday, July 15th.

8.30, Sports Notes. 9.0, Recital of Organ Music by Georges Jacob, followed by Programme of Dance Music relayed from the Coliseum de Paris. 12.0 Midnight (approx.), Close Down.

PARIS (Eiffel Tower), Call FL (2,650 metres); 5 kW.—8.56 a.m., Time Signal on 32.5 metres. 10.26 a.m., Time Signal on 2,650 metres. 6.45, Le Journal Parlé par T.S.F., read by its permanent contributors. Talks on "Health," "Police Anecdotes," "Notes on the Races," according to the paper "Paris-Sport," etc. by Dr. Pierre Vachet, Detective Ashelbé, MM. René Casalis, Julian Maigret, Pierre Descaves, Alexis Surchamps, Bertrand Dupeyrat, and others. 8.10, Weather Forecast. 8.30, Concert by Mario Cazes and his Orchestra. 8.56, Time Signal on 32.5 metres. 11.26, Time Signal on 2,650 metres.

PARIS (Radio L.L.), (370 and 60 metres); 1 kW.—3.0, Programme of Modern Dance Music arranged by Les Etablissements Radio L.L. 9.0, Concert arranged by the "Journal des Débats," Vocal and Instrumental Music and "Une Brouille," Poetical Comedy in One Act by Guy de Teramond et Barre, directed by Madame Claude Ritter of the Théâtre de l'Odéon.

PARIS (Petit Parisien), (340.9 metres); 0.5 kW.—8.45, Gramophone Records, followed by Talk and News Bulletin. 9.0, Orchestral Selections. 9.25, News Bulletin. 9.30, A Symphony Half-hour under the direction of Professor Estyle of the Paris Conservatoire. In the interval at 10.0, News Bulletin. 10.45 (approx.), Close Down.

PARIS (Radio-Paris), Call CFR (1,750 metres); 6 kW.—8 a.m., News Bulletin and Press Review. 12 Noon, Religious Address, followed by Choral Concert arranged by "La Vie Catholique," News in the interval. 12.45, Orchestral Concert by the Albert Locatelli Orchestra, Bilboquet in Variety Items. 4.30, Dance Music Programme by the Grand Vatel Orchestra, News in the interval. 8.0, News and Musical Selections. 8.45 (approx.), Orchestral Concert, News in the interval. 10.45, Close Down.

PITTSBURGH, Call KDKA (62 and 27 metres); 25 kW.—3.45, Telechron Time 4.0, Divine Service. 7.0, Roxy's Stroll relayed from Station WJZ New York. 9.0, Telechron Time Signal, followed by Dr. Sockman's Question Hour and Variety Programme, relayed from Station WJZ. 11.0, Telechron Time Signal, followed by Baseball Scores. 11.30, Concert by the KDKA Ensemble, conducted by Victor Saudek, relayed from the Palm Room of the William Penn Hotel, Pittsburgh. In the interval at 12 Midnight Telechron Time Signal. 1.0 a.m. (Monday), High Spots of Melody relayed from WJZ. 1.45 a.m., Programme by the Whittall Anglo-Persians from WJZ. 2.15 a.m., Concert by the Goldman Band, from WJZ. 3.15 a.m., Baseball Scores, followed by Telechron Time Signal. 10.30 a.m. (approx.), Close Down.

POSEN (344.8 metres); 1.5 kW.—10.15 a.m., Divine Service relayed from a Church. 12.0 Noon, Time Signal followed by Agricultural Report. 12.50, Bulletin of the Polish League of Youth. 5.0, Symphony Concert relayed from Warsaw. 6.30, Programme of Talks, including a Talk on Topical Events by Mr. B. Bista-kiewicz of the Journal "Tydzien Radjowy." 8.30, Concert of Light Music by Madame Wanda Dobroczyńska (Soprano), Kajetan Kopezynski (Baritone) and Jean Lewandowski (Accordion), with the "Lyra" Mandoline Orchestra. 10.0, Time Signal, News Bulletin, Weather Report and Sports Notes. 10.15, Variety Items. 10.30, Dance Music Programmes. 11.30 (approx.), Close Down.

PRAGUE (343.9 metres); 5 kW.—9.0 a.m., Agricultural Report. 12.0 Noon, Orchestral Selections 1.5, Commence Notes, followed by Miscellaneous Announcements. 5.30, Transmission for Workers. 6.0, German Transmission. 7.0 (approx.), Musical Programme. 10.0, Time Signal, and News Bulletin. 10.20, Orchestral Music from Brünn. 11.0 (approx.), Close Down.

ROME, Call IRO (450 metres); 3 kW.—10.15 a.m., Vocal and Instrumental Concert of Sacred Music. 11.0 to 1.30, Interval. 1.30, Concert by the Station Trio. 2.30 to 5.0, Interval. 5.0, Opening Signal followed by Concert from the Studio. 6.0, Half an Hour of Dance Music relayed from the Casinetta. 6.30 to 8.10, Interval. 8.10, Talks, followed by Sports Notes, News Bulletin and Forestry Report. 8.58, Time Signal. 9.0, Vocal and Instrumental Concert with Max Bruch's Concerto in G Minor Op 26 for Violin with Pianoforte Accompaniment. During the Interval Madame Pompadour's Fashion Talk. 11.5, Last News Bulletin. 11.15 (approx.), Close Down.

SCHENECTADY, Call 2XAD and 2XAF (21.96 and 31.4 metres); 30 kW.—4.0, Divine Service relayed from the First Baptist Church in Syracuse, New York. Sermon by the Pastor, the Reverend Dr. Bernard C. Clausen. 10.30, Recital by the Ballard Stringe relayed from New York. 11.0, The Stetson Parade, American Legion Band relayed from Boston, Mass. 12.0 Midnight, Recital by Hans Barth, Pianist, relayed from New York. 12.25 a.m. (Monday), Baseball Scores from New York. 12.30 a.m., Capitol Theatre Programme relayed from New York. 2.0 a.m., Talk on the American Government by David Lawrence, relayed from Washington D.C. 2.15 a.m., Atwater Kent Programme relayed from New York. 2.45 a.m., Correct Time. 2.47 a.m., A Biblical Drama relayed from New York. 3.15 a.m., Experimental Transmission of Television Signals. 3.30 a.m. (approx.), Close Down.

STAMBOUL (1,200 metres); 5 kW.—4.30, Orchestral Concert. 5.30, Market Prices. 6.15, Selections of Turkish Music. 8.15 (approx.), Weather Forecast followed by Orchestral Concert. 10.0, News Bulletin. 10.30 (approx.), Close Down.

STETTIN (236 metres); 0.75 kW.—6.30 to 9.0 a.m., Instrumental and Vocal Music relayed from Voxhaus. 11.30 a.m. to 12.0 Midnight, Programme of Talks, Concerts and Dance Music relayed from Voxhaus. 12.0 Midnight (approx.), Close Down.

STUTTGART (379.7 metres); 4 kW.—11.15 a.m. (approx.), Instrumental Concert followed by Open-air Concert relayed from the Castle Square in Stuttgart, and Gramophone Records. 2.0, Musical Programme for Children followed by Concert. 6.0, Time Signal and Sports Notes, followed by Popular Variety Programme—Dramatic and Musical—by the Station Orchestra and well known Artists. News at the end of the Programme.

TOULOUSE (Radio-Phonie du Midi (391 metres); 3 kW.—10.20 a.m., Market Prices for Gardeners. 12.30, Orchestral Selections. 1.0, Time Signal (Chimes). 1.45, Review of the Press. 2.0, Religious Address. 5.30, Exchange quotations and Review of the Press. 5.40, Weekly Agricultural Bulletin of the Confederation of the Agricultural Societies of South-West France. 8.0, Time Signal (Chimes) and Review of the Press, followed by Exchange quotations, Results of the Races, Market Prices of Metals. 8.25, Bulletin of the Automobile Club du Midi, the Confédération des Radio-Clubs du Sud-Ouest, the Association Générale des Commerçants Radio-électriciens du Midi. 8.30, Concert: (a) Selections for Balalaika, Guitar and Wind Instruments, (b) Programme of Tangos. 10.15, North African News Bulletin. 10.45, Programme Announcements for the Following Day, Weather Report, News and Press Review. 11.30 (approx.), Close Down.

VIENNA (577 and 517.2 metres); 1.5 and 5 kW.—Programme relayed by Innsbruck (291.1 metres), Klagenfurt (272.7 metres) and Linz (251.2 metres). 10.15 a.m., Programme of Music. 11.0 a.m., Concert by the Vienna Symphony Orchestra. 4.0, Vocal and Instrumental Concert, followed by Talks and Music. 8.15, "The Rose of Stamboul"—Operetta in Three Acts. Text by Julius Brammer and Alfred Grünwald, Music by Leo Fall. 11.0 (approx.), Close Down.

VILNA (435 metres); 1.5 kW.—10.15 a.m., Divine Service relayed from a Church. 1.0, Programme of News Bulletins and Talks, followed by Concert and Dance Music. 11.30 (approx.), Close Down.

WARSAW (1,111 metres); 10 kW.—10.15 to 11.45 a.m., Divine Service relayed from a Church. 12.0 Noon, Time Signal, Fanfare from the Tower of Notre Dame in Cracow, Aviation Report and Weather Forecast. 12.10 to 3.55, Interval. 3.55, Weather Forecast. 4.0 to 5.0, Programme of Agricultural Talks. 5.0, Vocal and Instrumental Concert by the Philharmonie de Varsovie organised by the Department of Public Instruction in Warsaw. 6.30, Twenty Minutes of Variety. 6.50, Talk on Polish History. 7.15 to 7.45, Interval. 7.45, Ethnography talk by Professor St. Poniatowski. 8.15, Popular Concert by the Orchestra of the Philharmonie de Varsovie, arranged by Polskie-Radio and relayed from the Dolina Szwajcarska under the Direction of T. Mazurkiewicz. Recitations, Songs and Orchestral Music. 10.0, Time Signal, Aviation Report and Weather Forecast. 10.5, News Bulletin, followed by Police Information and Sports Notes. 10.30, Dance Music Programme relayed from the Oaza Restaurant in Warsaw. 11.30 (approx.), Close Down.

ZURICH (588 metres); 1 kW.—11.15 a.m., Orchestral Concert. 12.29, Weather Forecast. 12.30, Instrumental Selections. The Station Quintet with interludes of Xylophone and Tubaphone Music by Leo Baumann. 1.30 to 4.0, Interval. 4.0, Orchestral Concert by the Carletti Orchestra relayed from the Carlton Hotel in Zurich. 7.30, Protestant Address. 8.0, Orchestral Concert. 10.0, Weather Report, Last News Bulletin. 10.15 (approx.), Close Down.

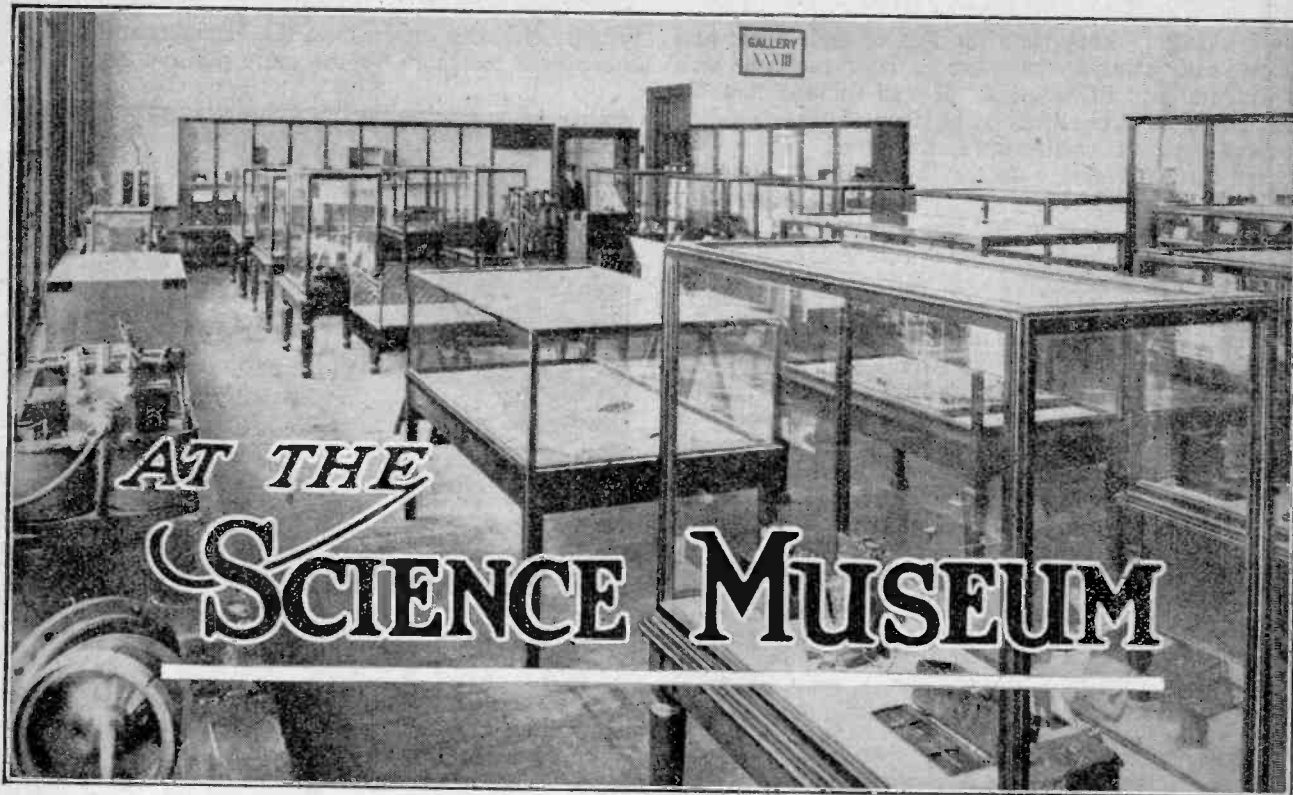

Some Recent Additions to the Radio Section.

By R. P. G. DENMAN, M.A., A.M.I.E.E.

THE publicity created by the recent Royal Opening of the New Science Museum Building at South Kensington, and the substitution of a fine new entrance for the old, furtive, tortuous passage in Exhibition Road, have naturally had the effect of attracting large numbers of new visitors. On Easter Monday no fewer than sixteen thousand were admitted, and there is little doubt that the million mark will be reached this year. It is thought that the following notes on a few of the recent additions to the Electrical Communication Section will be of interest to readers of this journal, and especially to those who may be making a visit to the Museum during the next few months. Special reference will be made to some interesting models and objects which, by reason of their slightly greater complexity, might be passed over by visitors anxious to see as much as possible in a short time.

It may not be out of place to point out here that,

unlike museums devoted to the Fine Arts, the importance of the objects in a Scientific Museum can seldom be estimated by their superficial attraction. For instance, at the time of writing a small and insignificant-looking object has been received, consisting of a pair of telephone receivers roughly mounted on either side of

a common tuning-fork. The casual visitor might easily pass rapidly from this object to those which follow, namely, a replica of the preliminary stages of the Rugby Transmitter (where a power of 1,000 kW. is controlled by a tuning-fork), and the original B.B.C. Harmonic Drive apparatus installed at Aberdeen in 1926. But neither of these outstanding achievements in frequency control would have been developed in this form had not the Eccles valve-maintained fork pre-

ceded them, just as it precedes them in this collection. It will be remembered that some years ago Dr. Eccles exhibited some three-dimensional models of valve

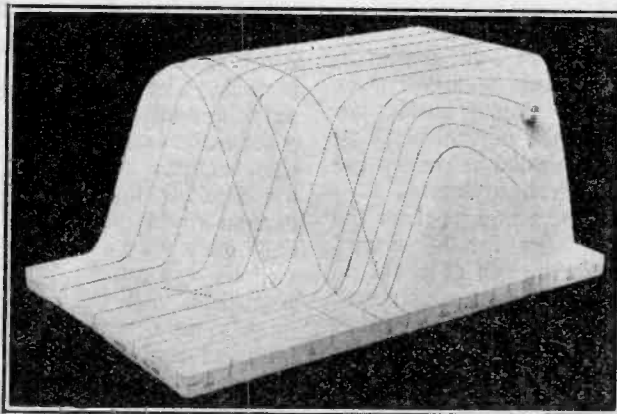

Fig. 1.—Three dimensional valve characteristic model for an LS5 valve showing the theoretical relation between the anode current, anode voltage and grid voltage.

At the Science Museum.—

characteristics. They were the first of their kind, and subsequently other models were made on the same plan in Holland and in America. It was decided that the Museum should construct a number of these models, and the work was carried out last summer. The valves chosen for illustration were the LS5, LS5A, and LS5B, together with a typical "soft" valve, the NR2A. The LS5 characteristic (Fig. 1) was constructed for the "ideal" case, and shows the theoretical relation between the anode current, anode voltage, and grid voltage, as given by the well-known Langmuir equation, but modified by the effects of saturation and secondary emission, as will be explained later.

Anode current is plotted vertically. Viewed from the front, *i.e.*, facing the grid voltage scale, the model represents the well-known series of anode current-grid voltage curves, and the lines drawn from left to right across the surface represent these curves for a few of the infinite number which can be drawn. Viewed from

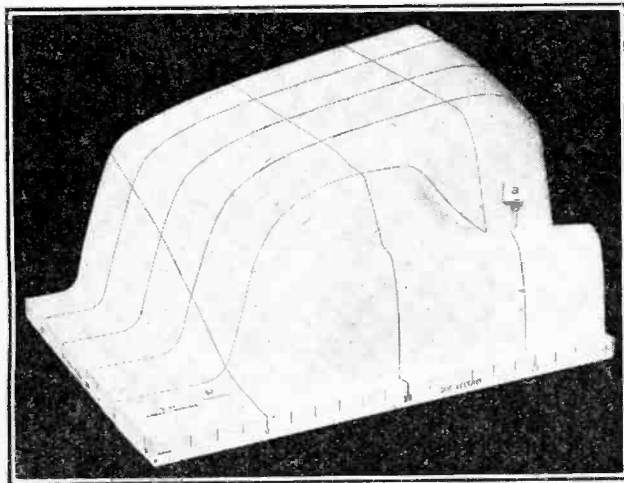

Fig. 2.—Observed anode current characteristics for an LS5B valve. When the anode voltage is above a certain value and the grid voltage exceeds that of the anode, the anode current declines as at the point marked (a).

the right-hand side, the lines drawn at right angles to these represent the anode current-anode voltage curves at constant grid voltage. The steep sloping surface on the left of the model is, of course, the normal working part of the characteristics. It is bounded below by the bottom bend and above by the saturation plateau.

The two succeeding models (Figs. 2 and 3) show the *observed* anode current characteristics for LS5B and LS5A valves, having amplification factors of about 20 and 2 respectively. Since all the models are constructed to the same scale, these amplification factors manifest themselves as the tangent of the angle formed between the cliff-like surface and the front edge of the model

$$(i.e., \mu = \frac{\delta v_n}{\delta v_g}).$$

It will be noted that when the anode voltage is above a certain value (actually about 25 volts in this case), and the grid voltage exceeds that of the anode, the anode current declines, as at the point marked (a) in the photograph. This effect is due to the copious liberation of

secondary electrons from the anode by the impact of primary electrons drawn from the filament, and to their subsequent recapture by the more positive grid. This

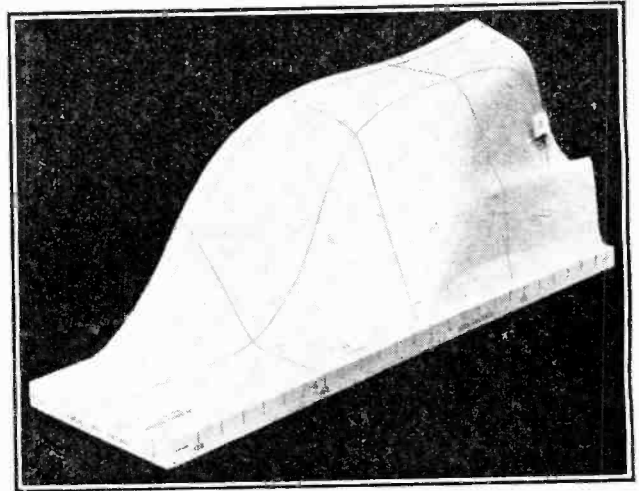

Fig. 3.—Observed anode current characteristic for an LS5A valve. As in Fig. 2 the point (a) represents the effect of the liberation of secondary electrons.

phenomenon is observed in all valves if the full characteristics are taken instead of the small portion which is normally used.

The grid current surface for an LS5A valve was obtained simultaneously with the anode current surface, and is given in Fig. 4.

The anode current characteristic of the NR2A, a soft valve containing helium gas, are shown in Fig. 5. The most notable feature of the soft valve is, of course, the sudden rise of current when the grid or anode voltage reaches the ionisation value. This gives rise to "discontinuities" in the curves, so that the flat sloping surface of the hard valve gives place to a vertical drop, or precipice, as shown to the left of the letter "f" in Fig. 5. This model was built up in horizontal layers corresponding to the constant current contours

which were actually plotted. The hard valve models were constructed in vertical sections from the familiar anode current - grid voltage curves at various anode potentials. All the models were made in wood and were then painted. The grid current characteristics of the NR2A valve were also plotted, but they are not shown here.

A model of great

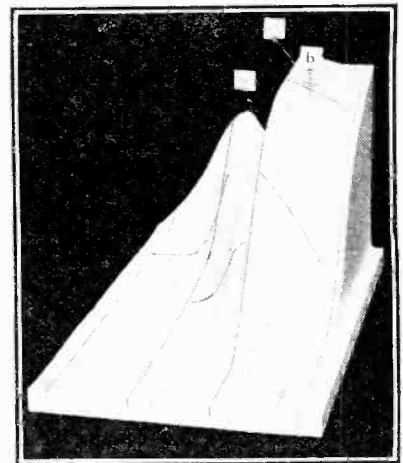

Fig. 4.—A model showing the grid current surface for an LS5A valve taken simultaneously with the anode current surface.

At the Science Museum.—

interest and fascination has recently been designed and presented by the Standard Telephones and Cables, Limited. It is a combination of a high-quality carbon microphone with a cathode-ray oscillograph, adapted for the visual inspection of acoustic wave-forms. Matters are so arranged that the wave-form produced by a 2ft. organ pipe blown by compressed air and directed towards the microphone may be viewed on the screen of the oscillograph, and in comparison with this approximately sinoidal wave-form one may then try the effect produced by singing or whistling into the microphone. The schematic diagram of the model is given in Fig. 6, from which it will be seen that the amplified potential of the wave-form to be studied is applied to the two plates AA of the oscillograph, and the time-base produced by the oscillating Neon tube arrangement is fed to the plates BB. In order that the frequency of recurrence of this time-base oscillation shall be synchronised as far as possible with the frequency of the wave-form under observation, a proportion of the output from the amplifier is fed to the oscillator. It is then no longer

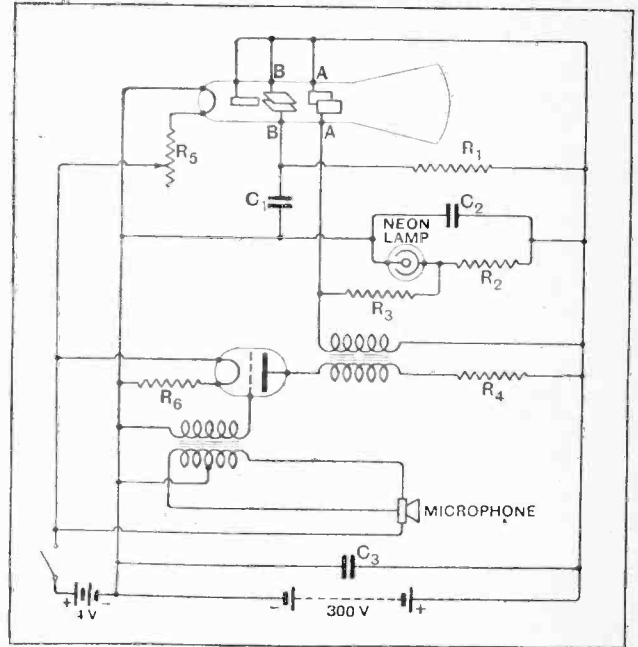

Fig. 6.—Circuit arrangement of the apparatus for the visual inspection of acoustic wave-forms, using a microphone and cathode-ray oscillograph. R_1 , 3 megs; R_2 , 5,000 ohms; R_3 , 20,000 ohms; R_4 , 300,000 ohms; C_1 , 0.01 mfd.; C_2 , 0.05 mfd.; C_3 , 1 mfd.

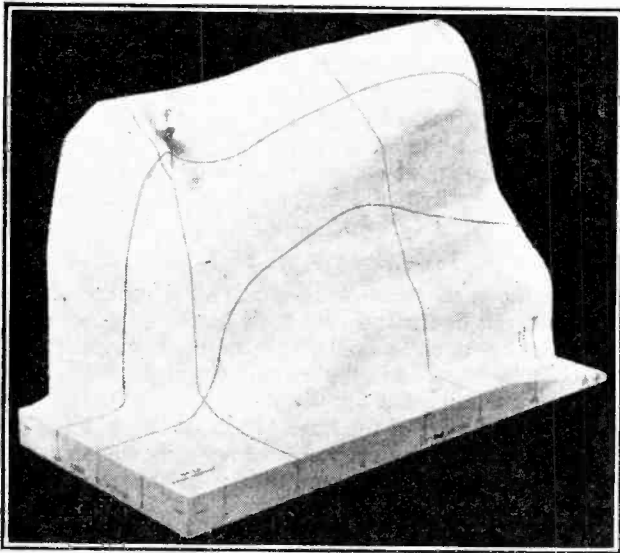

Fig. 5.—The anode current characteristics of the NR2A, a soft valve containing helium gas.

necessary that the latter frequency should be adjusted so as to be an exact multiple of the oscillator frequency, for this is automatically kept in step over the range of perhaps a semitone or so. In this way the designer has been able to reduce the number of controls on the model to one only, the L.T. switch, leaving the other hand of the observer free to manipulate the compressed air for the organ pipe.

It has, unfortunately, been found impossible to exhibit this working model in the Main Gallery, owing to the heavy cost of the tubes. It is kept in the adjoining Demonstration Room, where it may usually be seen in operation on application being made to the attendant.

Two ingenious models of electrical circuits are illustrated in Figs. 7 and 8. The first is Mr. R. C. Clinker's well-known model of an oscillating valve circuit, con-

structed in the Museum workshops and adapted for compressed air operation. In this model a string, whose motion represents the motion of the electrons in the anode circuit of the valve, is driven by a compressed air motor connected with a small pulley in the top left-hand corner of the baseboard. This string passes round a number of fixed pulleys and round a large, weighted pulley. It is also led round two small floating pulleys whose spindles are attached to the ends of an independent string, secured at its mid-point to the outer end of a flat spring. The motion of this spring actuates a compressed air valve, so that when the spring is de-

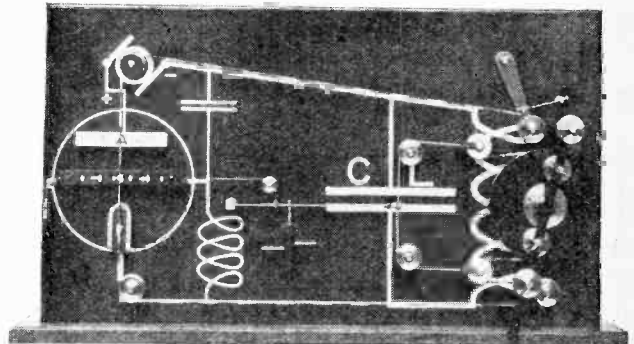

Fig. 7.—An ingenious model showing the mechanical analogy of the motion of electrons in the anode circuit of a valve.

pressed the valve is opened and the string moves faster. When it is raised the valve is closed and the motor stops. An indicator attached to the spring uncovers a series of positive or negative signs on the grid.

The action of the model, in mechanical terms, is as

At the Science Museum.—

follows: Upon the motor being started suddenly, the main string commences to move. The weighted pulley cannot, however, start immediately (owing to its "inductance"). Its lag causes the spring to be drawn

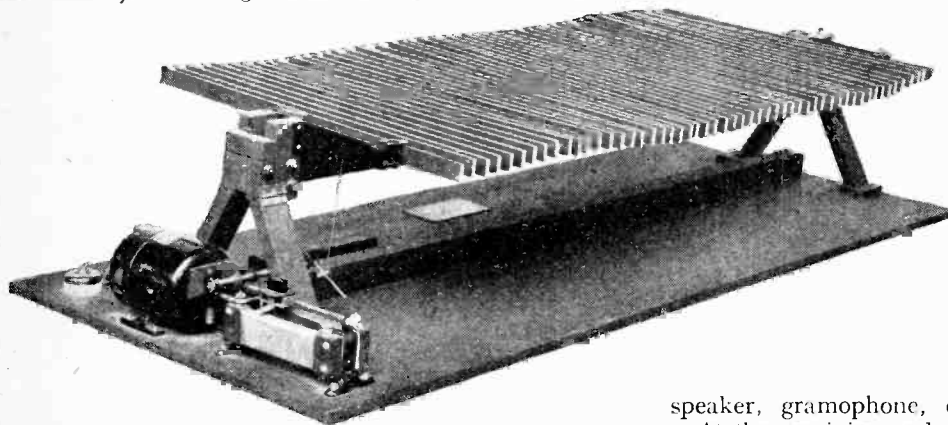

Fig. 8.—Vinycomb's Wave Motion Machine. A simple harmonic motion of constant amplitude is imparted at one end so that the nodes and loops produced by reflected waves can be studied.

downwards (*i.e.*, charges the condenser), displacing the upper and lower floating pulleys to left and right respectively. This action applies an accelerating torque to the weighted pulley, and also increases the speed of the string to a maximum by opening the air valve. During this time the mass gains speed, and the spring returns to the centre. When this happens, the weighted pulley has a greater peripheral speed than the small driving pulley, whose speed has been further lessened by the upward motion of the spring. Consequently the latter overshoots the central point, and in doing so shuts off the air and stops the driving pulley altogether. It then returns to the centre, again starting the string, and the operation is repeated, *i.e.*, continuous oscillation is set up. The string moves forward in a series of jerks, and the weighted pulley exhibits an oscillatory motion superposed on a unidirectional one.

The detailed action of the equivalent electrical circuit

and the disturbances pass along the system to the other end, where the terminal conditions which may be applied to the final lath determine the nature of the waves throughout the system.

If the end lath is clamped, or free, each wave is totally reflected, and by its encounter with the newly advancing waves produces the nodes and loops of a stationary system. Complete or partial reflection always occurs wherever there is an abrupt change in the impedance of a mechanical, electrical, or acoustic transmission channel, as, for example, at the junction of overhead and underground telephone lines, or in a poorly designed loud speaker, gramophone, or similar apparatus.

At the receiving end of the system, distortionless reception without reflection of energy can only be attained if the receiving apparatus is "tuned" to the characteristic impedance of the line. In the model this is secured by loading the final lath with a spring and with two air-damping vanes. When these are properly adjusted the waves are progressive—*i.e.*, the disturbances pass continuously from the driving end to the receiving end, although there is, of course, no material motion in this direction other than the slight compression and extension of the spiral springs.

Interesting Valve Models.

Since the mechanical resistance to the motion of the laths is small compared with their inertia reactance, the model forms a close analogy with the behaviour of a loaded telephone line, the amplitude of motion of the laths representing the amplitude of the current at any instant in any part of the line. It should be pointed out that whereas in the electrical analogy it is customary to assume constant voltage amplitude, in the model it is

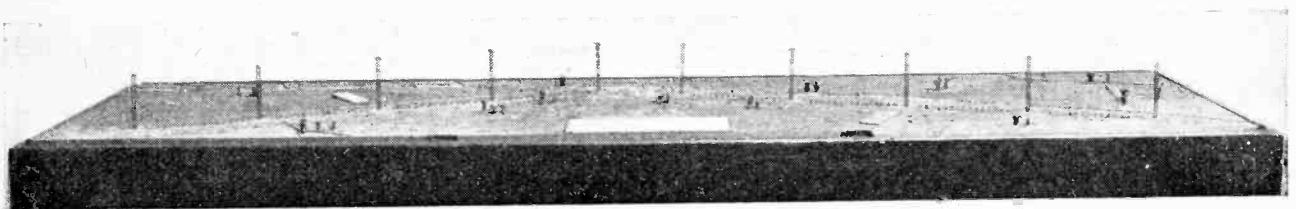

Fig. 9.—Model of the aerial system at the Bodium beam station.

is fairly well known and will not be given here. It should be noted that no clear mechanical representation of the grid circuit is to be sought for in the model. In respect of the anode circuit, however, the analogy is very close.

The second model, illustrated in Fig. 8, is known as Vinycomb's Wave Motion Machine, after its designer, Mr. T. B. Vinycomb, of the Woolwich Polytechnic. It consists of a number of wooden laths supported on two long spiral springs. An approximately simple harmonic motion of constant amplitude is imparted to the end lath

the maximum amplitude of displacement which is constant, for the drive is obtained from a rotating crank and connecting rod. Mr. Vinycomb has pointed out that this merely alters the scale of the response in a manner which varies slowly with frequency compared with the motion under constant force amplitude.

Progress in valve design is rapid, but an endeavour is made to keep pace in the Museum with the major developments. In addition to all the important valves of the past, visitors will find the Loewe, the screened grid valve, and the cooled anode transmitting valve con-

At the Science Museum.—

veniently sliced open for their inspection. Quite recently Messrs. Siemens and Halske have kindly sent over from Germany a series showing the early work of Schottky on four-electrode valves.

The Marconi Company have made very many important contributions, and some years ago they transferred to the Museum the whole of their private collection, including many of Senatore Marconi's earliest instruments. To this they have recently added models of the aerial systems at Berne and at the Bodmin Beam Station (Fig. 9), which were constructed for exhibition at the Volta Centenary Exhibition at Como last year and created much interest.

The Museum Demonstration Receiving Set is now well known and need not be described here. The special purpose of this set—to give (as far as possible under somewhat awkward acoustic conditions) regular demonstrations of what is at present to be understood by "good quality" transmission and reception—has been correctly interpreted by the majority of visitors, for whose convenience it was found necessary to publish the schematic diagram of the set (see Fig. 10). About one thousand of these diagrams have been sold, and it is therefore much to be hoped that the self-imposed limitations of its designers have been generally understood, for without modification the set is, of course, unsuitable for anything beyond very local reception.

General interest appears at last to have been aroused in the advantages of electrical reproduction from gramophone records. This new branch of gramophone

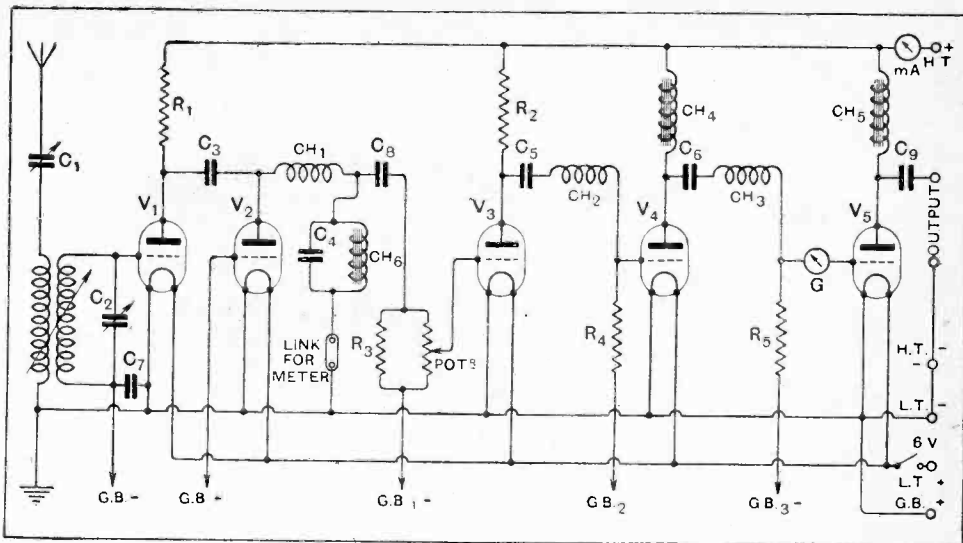

Fig. 10.—The circuit arrangement of the high-quality demonstration receiver at the Science Museum. C₁, 0.0005 mfd.; C₂, 0.0005 mfd.; C₃, 0.0002 mfd.; C₄, 0.0002 mfd.; C₅, 0.5 mfd.; C₆, 0.5 mfd.; C₇, 1 mfd.; C₈, 1 mfd.; C₉, 4 mfd.; R₁, 20,000 ohms; R₂, 50,000 ohms; R₃, 100,000 ohms, bridged by a potentiometer of 100,000 ohms; R₄ and R₅, 0.25 megohms. V₁, DE5 class; V₂, LS5B class; V₃ and V₄, DE5 class; V₅, LS5A class.

technique is dealt with in Gallery XLIII, where demonstrations are given on most days with the H.M.V. electrical reproducing equipment, a description of which appeared recently in this journal.

To conclude, the author would always be interested to hear from readers in all countries who might be good enough to acquaint him of possible acquisitions of historical or modern importance. Objects illustrating inventions which mark a definite step in the progress of electrical communication are chiefly intended, and with few exceptions objects of subsidiary interest, such as documents, and so on, are not suitable for exhibition.

Like the subjects with which it is concerned, this Museum is international in scope. If the publication of this article should ultimately bring about the arrival of new exhibits from France, Germany, Sweden, America, or Japan, foreign visitors to the Museum no less than British will reap the benefit.

Short Waves from Denmark.

Signals on 84.24 metres, including picture transmissions, are being sent out regularly throughout July by ED7RL Radiolytteren, Raadhushplads 55, Copenhagen V. The transmissions occur every Monday and Friday, beginning at 11 p.m. and continuing until 1 a.m.

o o o o

A Hamfest in London.

The Sixth London Area Hamfest is to be held at Pinoli's Restaurant, Wardour Street, W., on Tuesday next, July 17th, at 7 p.m. Tickets, price five shillings, can be obtained from Mr. J. Clarricoats, Chairman of the Social Committee, R.S.G.B., 107, Friern Barnet Road, London, N.11.

It is hoped that among those present will be representatives from several foreign countries, and the committee

TRANSMITTERS' NOTES

issues the assurance that all present will thoroughly enjoy the evening.

o o o o

New Call-signs and Stations Identified.

- G5GF** H. Stopher, 88, Churchinore Rd., Streatham Vale, S.W.16. (Change of address).
- G150T** H. V. Scott, 41, Hawkin St., Londonderry, transmits on 45 metres.
- 2ABH** M. Woodroffe, Westington, Chipping Campden, Glos., will be glad to report on any wavelength at any time during the week.
- 2AHU** R. T. Pursey, Farmcote, 2, Northdown Way, Cliftonville, Margate.
- 2AHX** W. F. C. Geraghty, 5, Benson St., Norton, Stockton-on-Tees.
- EB4TO** Ad. van de Kerchove, Lasne, Brabant, Belgium, transmits on 45 metres and wishes to get into touch with British amateurs during the day time.

Heard in South Australia.

Mr. R. M. Anthony (OA5CM), 3, High Street, Unley Park, South Australia, sends us, through Mr. A. H. Gilbert, of Wimbledon, a list of British amateurs heard on the 23 metres band during March and April last:—

Call Sign	Strength	Call Sign	Strength
2 KF	R5	5 HS	R5
2 BM	R4	5 BY	R4
2 AO	R4	5 XY	R4
5 MA	R5	5 YK	R4
5 AD	R4	6 WY	R4
5 JW	R5	6 VP	R5
5 UW	R4	6 WI	R5

Further details of reception will be gladly furnished on request.

o o o o

Latvia.

We understand that the forwarding agent for Latvia is M. Karklin, Tvaika 34, Riga.



By Our Special Correspondent.

**Broadcasting from Ypres.—The Clapham Research Station.—5SW's New Schedule.—
Fewer Talks.—Broadcasting Position in France.**

Broadcasting from the Menin Gate.

One of the most interesting events in the early part of next month will be the relay from Ypres of the Menin Gate Memorial Service of the British Legion on Wednesday, August 8th.

The technical arrangements for the relay will be practically similar to those used at the opening of the Menin Gate on Sunday, July 24th, last year. All British stations will relay the service, and I understand that the transmission will be tapped by the Belgian broadcasting authorities.

o o o o

The Service.

The service, which begins at 11.30 a.m., concluding about noon, will consist of hymns and prayers, an address by the Archbishop of York, the sounding of the Last Post and the Réveillé, and the singing of the national anthems of Belgium, Britain, and France.

Last year, it will be recalled, the transmission was nearly perfect, except during a portion of King Albert's speech, when line disturbance caused an unfortunate break. This year every effort is being made by the British and Belgian engineers to ensure a perfect transmission.

o o o o

With the B.B.C. at Clapham.

A certain amount of surprise appears to have followed the announcement, made in these columns a fortnight ago, that the B.B.C. staff at Clapham now numbers 76.

"Does the B.B.C. actually employ 76 engineers on research?" asks more than one querist. The answer is, of course, in the negative. The above-mentioned number includes typists, clerical assistants, and, last but not least, a jobbing gardener whose main task is to keep the weeds under control in the extensive grounds.

By the way, many perspiring amateur gardeners might appreciate a talk on weeds by the B.B.C. Weed Controller. What about it, Savoy Hill?

FUTURE FEATURES.

London and Daventry.

- JULY 15TH.—Bach's Church Cantata, "Behold Salvation Cometh Now."
JULY 16TH.—Musical Comedy Programme.
JULY 17TH.—A Military Band Concert.
JULY 18TH.—"Hamlet," by William Shakespeare.
JULY 19TH.—Charlotte's Hour.
JULY 20TH.—Surprise Feature.
JULY 21ST.—Light Orchestral Concert.

Daventry Experimental (5GB).

- JULY 15TH.—Albert Sandler and His Orchestra.
JULY 16TH.—Symphony Concert.
JULY 17TH.—Variety Programme.
JULY 18TH.—A Military Band Concert.
JULY 19TH.—An Orchestral Concert.
JULY 20TH.—Ballad Concert.
JULY 21ST.—Variety Programme.

Cardiff.

- JULY 15TH.—National Orchestra of Wales and Vocalists.
JULY 17TH.—An Eye - Witness account of the England v. Wales Tennis Match, by Peter Freeman.

Manchester.

- JULY 16TH.—An Animals' Carnival.
JULY 21ST.—An Eye - Witness account of the first day's play in the Second England v. West Indies Test Match, played at Old Trafford.

Newcastle.

- JULY 17TH.—Launch of "H.M.S. York" by H.R.H. the Duchess of York, relayed to London and Daventry.

Glasgow.

- JULY 19TH.—Ladies' Night.

Belfast.

- JULY 16TH.—A Programme of Folk Music.

What Would the Censor Say?

An organisation of the dimensions of the B.B.C. naturally employs a large collection of "supernumeraries." Which suggests that there might be less interesting topics for a winter talks series than "Savoy Hill Secrets" by "The Lady with a Duster."

o o o o

Mr. Baldwin to Broadcast.

The Prime Minister's speech at the assembly of the National Savings Association will be relayed to 2LO from the Hotel Majestic, Harrogate, on July 20th at 9.15 p.m.

o o o o

For Listeners in India.

Principally for the benefit of listeners in India, 5SW is to begin a special early evening transmission on alternative Fridays, commencing on Friday next, July 13th. Hitherto the Chelmsford station has opened its evening transmission at 7 p.m., but on the evenings mentioned a start will be made at 6 p.m. (B.S.T.), with a break between 6.30 and 7.

o o o o

An Industrious Playwright.

Cecil Lewis, who recently travelled to the peaceful Italian lakes to carry out his ambitious task of writing eight or nine radio plays, will return to London towards the end of this month with the first fruits of his labours. No fewer than three of these plays will be broadcast within nine days of each other. "Improvisations in June," an adaptation of a German play by Max Mohr, will be broadcast from 2LO on July 25th, while "Good Breeding," an original play by Cecil Lewis, is to be produced at 2LO on August 1st. He has also written a comedy sketch, "Chez Cupid," which will be included in London's variety programme on July 28th.

o o o o

Gracie Fields to Broadcast.

One of the catches of the season in B.B.C. variety programmes is Gracie Fields, who will make her broadcast

debut on Wednesday next, July 18th, from 2LO and 5XX.

The famous comedienne originally made her name in Manchester, and her subsequent success has supported popular dictum that what Lancashire thinks to-day, etc.

o o o o

Fewer Talks.

The last of the school talks for the present session was given last week, and the series will not be resumed until the autumn. Another indication that the holiday season is upon us will be the cessation of the 7.25 p.m. talks series early in August. Thereafter, until September, the listener will be able to avail himself of self-contained talks of an informal nature, not belonging to a series. One of these will be given by Mr. Norman Angell on "Newspapers and Public Opinion"; there will also be a talk on "Detective Novels."

The half-hour talk on Tuesdays from Daventry will also be dropped after July 17th.

o o o o

Farewell to the Colours.

Three household terms in America have just faded out of existence. They were "Blue Network," "Red Network," and "Pacific Coast Network," describing the three big groups of stations linked together under the National Broadcasting Company. To save confusion, programmes in future are simply to be labelled as emanating from stations associated with the N.B.C.

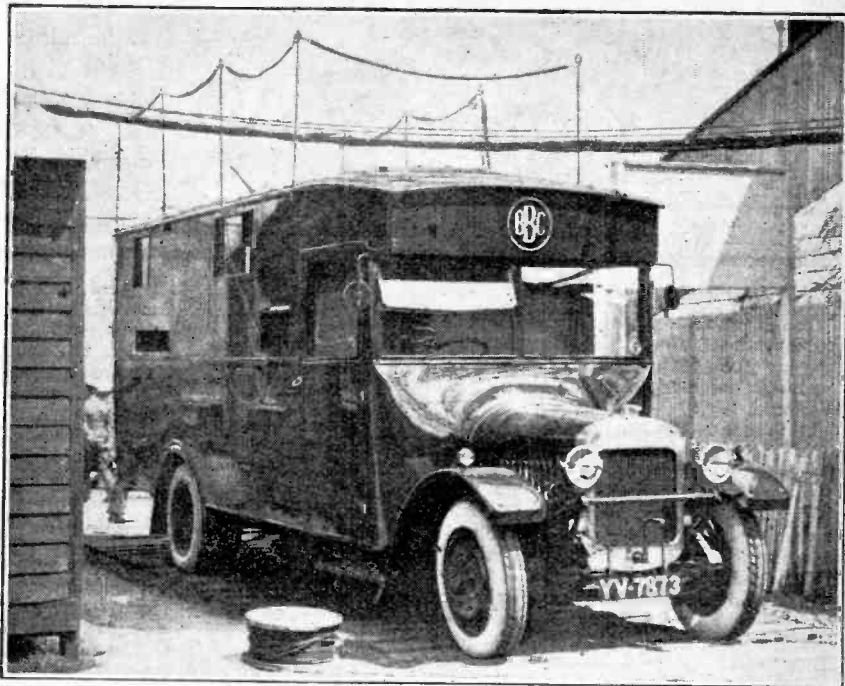

THE "O.B." VAN. The B.B.C.'s newest vehicle photographed at Hendon on the occasion of the R.A.F. display. This van, which received first exclusive mention in these columns, embodies a control room and miniature "studio." It is used exclusively for outside broadcasts.

laid before the Chamber a few days ago provides for State ownership of the majority of broadcasting stations. According to the Bill, there are to be twenty-one stations in all, a few of them being conceded to private interests for a period of five years, the Government having the option of purchasing the stations after that period.

In some respects the Bill countenances Government intervention to a greater extent than obtains in this country. For instance, the technical side of broadcasting, if the Bill passes, will be under the control of the Ministry of Posts and Telegraphs. The programme side will also be under supervision, control being exercised by the Ministry of the Interior.

o o o o

"Potash and Perlmutter" on Tour.

Julian Rose and Nick Adams, of "Potash and Perlmutter" renown, will broadcast from 2LO on July 31st. They are touring other B.B.C. stations each evening during the same week, i.e., July 30st to August 4th.

o o o o

Hamlet's First Microphone Appearance.

A broadcast version of "Hamlet," produced by Tyrone Guthrie, is to be given from 2LO, 5XX, and other stations on July 18th. The play as written is too long for microphone performance, so the narrative will be linked up by Dorothy Holmes-Gore. The parts of the King and Queen will be taken by Irene Rooke and Leslie Perrins, while "Hamlet" will be Gyles Isham, a coming stage celebrity. This is the first time that "Hamlet" has been broadcast by the B.B.C.

General Nuisance and His Army.

Tommy Handley is now regarded as the "star" radio comedian. His recent revue, "Inmanninn," evoked more letters from listeners than any previous revue in the last two years. Considering that the letter bag generally gets little patronage during the summer months, this is a very high tribute indeed.

"Tommy's" next revue, under the title of "Handley's Manœuvres," will be presented from 5GB on August 3rd, and 2LO and other stations on August 4th. The author will take the part of General Nuisance, P.T.O., A.S.S., R.S.V.P., and the cast will include girl guides, boy scouts, and V.A.D. nurses. Other members of the party will be the Very Orderly Officer (John Armstrong), the Regimental Pets (Jean Allister and Miriam Ferris), and the Batty Batman (Philip Wade).

o o o o

Where Was the Whistle?

Rare resourcefulness was shown by an official at 2RN, the Dublin station, a few days ago. A dramatic sketch was in progress, and towards the climax it was necessary that the shrill tones of a police whistle should ring out. Unfortunately, it was discovered at the last moment that the whistle was missing. There was a frantic search, growing more frantic as the play proceeded. When, however, the tension had reached its maximum, a member of the staff came rushing in brandishing a police whistle, followed by its owner, a passing "bobby," who seemed quite honoured at being invited into the studio to hear his whistle broadcast over Southern Ireland!

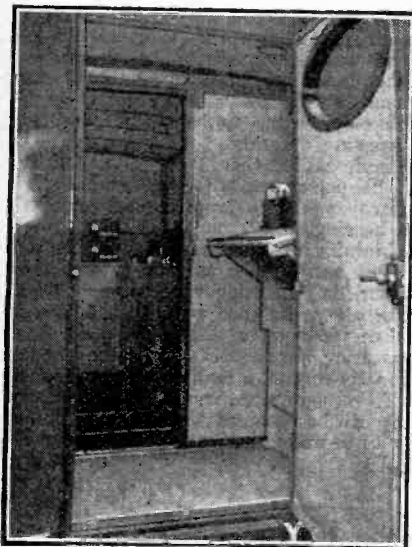

IN THE "O.B." VAN. A glimpse inside the B.B.C.'s newest vehicle. In the background is the control room, while nearer the camera is the sound-proof compartment containing the microphone.

Will France Copy Britain?

Despite the antagonism in many quarters to the notion of a State-owned broadcasting service, France appears to be following the British example. At any rate, the Government Broadcasting Bill



The Editor does not hold himself responsible for the opinions of his correspondents.

Correspondence should be addressed to the Editor, "The Wireless World," Dorset House, Tudor Street, E.C.4, and must be accompanied by the writer's name and address.

THE CONTROL ROOM.

Sir,—I would like to associate myself with every word your correspondent Mr. G. B. Hargreaves, in his letter appearing in your June 20th issue, says on the subject of the artificial "control" of modulation by the B.B.C. in their musical transmissions.

As it stands the gramophone electrically reproduced through a really good amplifier and loud speaker system seems able to give a truer musical result than is possible from a B.B.C. transmission of the same thing, simply because in the case of the gramophone one finds recorded the full contrasts between fortissimo and pianissimo, with a result that is alive as compared with the deadness or flatness of the "controlled" and mutilated B.B.C. transmission.

It would seem almost axiomatic that, the optimum mean modulation adjustment for a given musical transmission having been ascertained, that adjustment should be left severely alone during the performance of the piece.

Beaconsfield, Bucks.
June 25th, 1928.

C. G. BANISTER.

RECEPTION OF 5SW.

Sir,—Referring to paragraphs on 5SW, page 562 of your valuable paper of May 23rd, I don't think your correspondent of Ahwaz has solved the problem yet. I think he should look for the solution at his end. It appears to me from a number of the home papers that 5SW is not getting the credit it deserves. Anyone who can't get 5SW seems to put the blame on that excellent station straight away.

I have only a two-valve set and can get 5SW's programme at L.S. strength any time they are broadcasting after sundown here; every word is as clear and distinct as if the speaker were in the same room as myself. There is not much difference in the quality between 5SW and PCSS, but I give the former first place every time.

Lahore, India.
June 9th, 1928.

C. B. LEALEY.

MOVING COIL REPRODUCTION.

Sir,—I was very interested to read Mr. Cole's letter in your issue of June 27th.

I have been working on a M.C. speaker for some seven months, and must admit that as far as wireless reception is concerned I am still not satisfied with the results. I have used both high and low resistance coils, cones of various sizes, and a variety of amplifier arrangements.

When I first got the speaker running I was extremely pleased, but soon became critical, and I find that the longer one uses this type of speaker the less tolerant one becomes of any defects.

Volume.—I have never obtained decent results unless the volume has been very considerable. Anyone hearing the speaker for the first time considers the volume too great, but one soon gets used to it. I think there is no doubt that the output volume must be comparable with the original input in order to obtain realistic reproduction.

Coils.—I have not found any very marked difference between a high and low resistance coil. I think the high resistance type is rather more efficient, but it is very difficult to make any quantitative tests worth much. The best results have been obtained, I believe, with a coil having about 2,000 turns of 46 S.W.G. enamelled wire on a 2in. former. This operates in a 5/64in. gap. There is a very little clearance, as may be

imagined, and I would not advise anyone to attempt to reproduce this coil, as the margin is too small. This winding, fed from a choke, is very efficient. However, generally speaking, I think the winding of the moving coil is of secondary importance as compared with the amplifier, at any rate as far as quality is concerned.

Cones.—I have found nothing better than the Bristol board, which is usually recommended. As to diameter, I have found that a cone about 8in. diameter is better than one 6in. in diameter. This is a point where the experts do not agree. Captain Round states that 6in. is as big as it is advisable to go, whereas Mr. McLachlan recommends a larger one. I do not find that the freedom of support is very critical. Most of my cones have been more free to move than is usual on commercial examples.

Amplifier.—I really think this is the key to the whole matter. The maximum H.T. available in my case is about 200 volts off D.C. mains. I can quite definitely state that the best results are obtained from a push-pull arrangement using L.S. 5A valves (two in all). I have tried D.E. 5A, but they are not so good. The valves are fed from a Ferranti transformer, through leaks (to prevent interoscillation). The output is obtained from a 25-1 Ferranti (unless a high resistance coil is being used). The push-pull scheme seems to bring out the low notes, though I am beginning to find that one has to go further back, and that the output stage is not the only one to bother about. The detector seems to have a marked effect on the performance, and I am just tackling this point now.

It is really remarkable how one can go on improving the performance of the amplifier, and how this leads to discovering notes, of which one was previously quite unconscious. An excellent test is the dance music. There is a drum or some such instrument which booms away more or less continuously, and which only begins to be really audible as one gets the amplifier working decently. If the average experimenter is not much more skilled than I am (an unfair suggestion, perhaps), and he perseveres with his amplifier, he will be astonished to discover what a large percentage of the music he has not been hearing.

One hears of people obtaining excellent results by the use of one D.E. 5A as an output valve. The only conclusion I can come to is either that there is something very wrong with my equipment or that anyone who is satisfied with D.E. 5A results has never heard a speaker working anything like well.

It would be most interesting if someone who has had experience with a M.C. speaker working off a really high grade amplifier, and using high H.T. voltages, etc., would give his experience of the results which can be obtained from a D.E. 5A output. I refer to quality of reproduction rather than volume.

Wolverhampton,
June 30th, 1928.

C. H. S.

Sir,—Your correspondent Mr. Cole has found that volume can be satisfactorily controlled by varying the magnetising current to the pot magnet of his coil-driven loud speaker.

This method is certainly simple, effective, and worthy of some attention on the part of constructors. The writer uses a 6-volt pot winding consisting of two equal coils which may be put either in series or in parallel by means of a small switch attached to the speaker. This arrangement, together with an external resistance of about 12 ohms, enables a magnetising force varying from about 600 amp. turns to 3,000 amp. turns to be used.

The addition of an extra valve in parallel in the output stage produces a negligible increase in volume compared with that

due to an increase in magnetising force from 600 to 3,000 amp. turns.

The writer has made the same comparison as Mr. Cole between the high and low resistance types, but using the same size gap for the moving coil in each case. The impressions made upon the writer were: (a) that the low resistance type of instrument gave the most pleasing musical balance with excellent definition; (b) that the high resistance type gave a slightly greater response over the middle frequencies and a lesser response in the base attended there at least by some lack of clear definition; (c) that nine out of ten people would not distinguish any noticeable difference between the two types; (d) that better definition results in the case of the high resistance type when a 1:1 output transformer is used in place of a choke filter output.

The writer is now using a low resistance type of instrument having a gap for the moving coil of 45/1,000th of an inch. This gap was originally made 25/1,000th, but it appeared that the magnetising force available was producing saturation in the pot magnet, and therefore it was less advantageous to retain such a small gap than to have a little more room available for the moving coil. Various writers in *The Wireless World* have mentioned the advantages of the low resistance type from the point of view of construction and of operation at a distance from the amplifier.

Now a few words about reception. Is there anyone using a well-designed coil-driven speaker and near enough to 2LO for practically perfect detection who has not been annoyed by faults and defects in the transmissions resulting from the so-called "control," defective acoustics of the studios, and of silence cabinets, from which announcements are made, etc.? And who has not suspected the receiver or speaker until experience and discrimination leads one to more accurately assign the blame?

Finally, with all due acknowledgment to the B.B.C. for the noticeable efforts being made by them, may it be hoped that the occasions for complaint may become more and more rare.

Trusting this letter does not trespass too greatly on your valuable space.

Canonbury, N.1,
July 2nd, 1928.

WALTER OLIVER.

Sir,—I should like to make a few comments on a letter written to you by Mr. Lionel Cole on the subject of "Moving Coil Reproduction." In my humble opinion he has obtained exactly the results one would expect, but has not drawn the correct conclusions from the experiments. It would seem to me that No. 1 speaker was a really good instrument, but that No. 2 was hopelessly inefficient.

The fault of experiment No. 1 was simply that the speaker was delivering too much volume, and a judicious "toning down" of the receiver would have produced results comparable with speaker No. 2, assuming, of course, that tonal qualities of the two speakers were equal and the receiver constant.

It is well known that when the volume of a speaker is reduced the bass fades much more rapidly than the treble, so reducing this to an absurdity, a point would be reached where only the treble remained. The "slight accentuation," mentioned by Mr. Cole, of the treble is only a question of amount of reduction. By reducing the field strength he has rendered speaker No. 2 still less efficient. Personally, I should prefer to keep the magnetic field strength as high as is reasonably possible, and control volume by a valve as near the aerial end of the set as possible. It is surely of no importance, from the tone point of view, whether the gap is small or large, or the coil high resistance or low with transformer. These points only decide the efficiency of the instrument. I hope others will come forward with their views.

Blackheath.

July 27th, 1928.

A. F. B.

IDENTIFICATION OF FOREIGN STATIONS.

Sir,—May I question Mr. Southern's "axiom"? (Letter on "Identification of Foreign Stations," *The Wireless World*, June 27th.) He writes:—"I suppose it may be taken as an axiom that a listener wishes to know what station he is hear-

ing?" But why? Listeners to foreign stations may be divided into two main categories: (a) those who wish for entertainment, (b) those with a scientific or semi-scientific interest in distant reception (range, fading, etc.).

(a) For entertainment purposes, we want to know, for example, that condenser settings of 27½°, 48°, will usually bring in dance music at 8 p.m. on Sunday (when the vaunted "alternatives" offered by the B.B.C. are a choice of religious propaganda). For pure "entertainment," what more is required? It does not matter whether it is "Petit Parisien" or "Voxhaus."

(b) In the case of those interested in distant reception, *per se*, we may assume that some sort of notebook or written record will be kept (without which little more is gained than the ability to boast: "I got Timbuctoo on a crystal"). From notes of the condenser settings for a few (English) stations a rough calibration curve for the receiver can be plotted, from which a fairly accurate estimate of the frequency of the unknown station can be made; a rough estimate of the signal strength, and a reference to a list of stations arranged in order of frequency, giving power and distance from the receiver, will usually leave little doubt of the identity. Without much knowledge of foreign languages, one can usually tell if the announcer's words are in one of the groups French-Italian-Spanish or German-Dutch-Flemish, if confirmation is required. I further suggest that if any serious work is undertaken, or if the listener has more than one receiver, some form of wavemeter is almost a necessity, and can be constructed very cheaply (absorption wavemeter, say, £1, heterodyne £3). Descriptions of many have appeared in *The Wireless World*. This should give readings to within about 1 per cent., in itself sufficient to identify almost any station.

I suggest that category (a) in search of entertainment outnumber (b) (who can, as suggested above, locate their station by its frequency if they have sufficient technical knowledge for their observations to be of much use), and why should the majority suffer interruption of their programme to satisfy the curiosity of a minority?

C. R. COSENS.

Cambridge,

June 28th, 1928.

MUSIC RECEIVER.

Sir,—"W. M. G.'s" enquiry for a receiver that will reproduce music only is, I am afraid, at present, asking for the impossible. If anyone can invent a receiver that will receive music, but which utterly refuses to reproduce the human voice, he will make a colossal fortune; he can market it at an exorbitant price, and even so 90 per cent. of listeners will buy it!

But he can hope for no help in his researches from the B.B.C.

Cambridge,

June 28th, 1928.

C. R. COSENS.

HOSPITAL INSTALLATIONS.

Sir,—As we have close on 30 receivers working entirely and successfully off the mains in hospitals in London and district, we are in full accord with the letter of the Marconiphone Company in your issue of June 27th, when they expressed the view that mains-operated installations are the only satisfactory solution.

We differ, however, from the Marconiphone Company when they suggest that a visit to the set once a week should be necessary. Most emphatically we would say that we have not found it so. On the contrary, every hospital set of ours has operated for a period of at least six months without any attention whatever except the moving of a switch on the wall, the set being locked up, and in most instances we ourselves hold the keys. One has not had to be unlocked for two years. Of another, that has already been in operation two and a quarter years, the door has only once been opened, and that only for a slight detuning to cut down volume.

As regards automatic control, we have found no call for this: but we are all ready to fit time switches should these be required.

W. E. H. HUMPHRYS.

London, W.1. (Managing Director, Read & Morris, Ltd.)
June 28th, 1928.

READERS' PROBLEMS

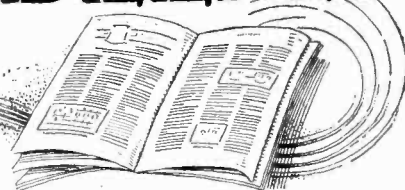
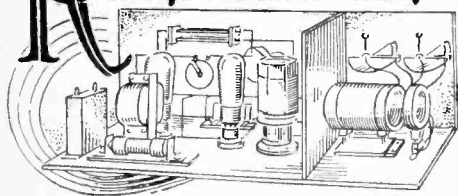

"The Wireless World" Supplies a Free Service of Technical Information.

The Service is subject to the rules of the Department, which are printed below; these must be strictly enforced, in the interest of readers themselves. A selection of queries of general interest is dealt with below, in some cases at greater length than would be possible in a letter.

An Indoor Aerial Tip.

It is necessary for me temporarily to operate my receiver on a short indoor aerial only about 15ft. long. The set comprises H.F. amplifier, detector, and two L.F. stages, and has given exceptionally good results on a full size aerial. Can you offer any suggestions as to how I can get the best out of it under present conditions?

W. F. T.

Your receiver probably includes the usual feature of an "aperiodic" aerial coupling, which will be designed to give a good compromise between selectivity and maximum signal strength on an aerial of normal characteristics. With the short length of wire you are at present using it is more than likely that the coupling to the H.F. grid circuit is exceptionally weak, and we suggest that you should try the effect of joining the aerial directly to the grid of the H.F. valve. In all probability this alteration will give a very considerably increased range.

○ ○ ○ ○

Synonyms.

What is the difference between the expressions "amplification factor," "magnification factor," and "voltage factor" as applied to a valve?

H. L.

There is no difference between these expressions as commonly used. They merely represent different ways of saying the same thing.

○ ○ ○ ○

A Short-wave Attachment.

My receiver is of a composite type, the first H.F. stage having an ordinary three-electrode valve with neutralised transformer coupling, followed by a screened grid valve. If you consider the idea to be practicable, I should like to make up a superheterodyne unit for reception of the short waves, using the present first valve as a signal-frequency detector (anode bend) and the second H.F. stage as an I.F. amplifier. Will you give me a circuit diagram of the attachment?

C. J.

It should be possible to get the arrangement you propose to work quite well, and we give the circuit of a suitable unit in Fig. 1. It might be made in such a way

that it can easily be connected to the set by a connector strip device, or in any other convenient manner.

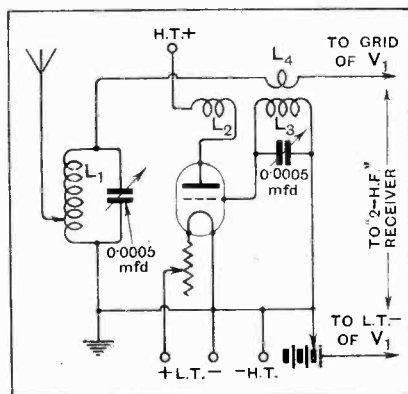

Fig. 1.—An oscillator unit for converting an existing "2 H.F." set into a short-wave superheterodyne.

RULES

(1.) Only one question (which must deal with a single specific point) can be answered. Letters must be concisely worded and headed "Information Department."

(2.) Queries must be written on one side of the paper, and diagrams drawn on a separate sheet. A self-addressed stamped envelope must be enclosed for postal reply.

(3.) Designs or circuit diagrams for complete receivers cannot be given; under present-day conditions justice cannot be done to questions of this kind in the course of a letter.

(4.) Practical wiring plans cannot be supplied or considered.

(5.) Designs for components such as L.F. chokes, power transformers, etc., cannot be supplied.

(6.) Queries arising from the construction or operation of receivers must be confined to constructional sets described in "The Wireless World" or to standard manufacturers' receivers.

Readers desiring information on matters beyond the scope of the Information Department are invited to submit suggestions regarding subjects to be treated in future articles or paragraphs.

The valve functions as an oscillator: L_1 is the aerial-grid coil, and L_2 and L_3 are plate and grid inductances. L_4 is the pick-up coil.

○ ○ ○ ○

Trouble with a Relay.

When a relay is inserted in the anode circuit of a valve, how is it possible to prevent the steady anode current which flows when no signals are coming in from closing its contacts? I find that it is possible to keep the relay contacts open only by over-biasing the grid so heavily that the increased current due to a signal is insufficient for its operation.

V. W.

It seems very probable that you have not made provision for sufficiently fine adjustment of grid voltage, and we recommend that you should use a potentiometer in conjunction with a tapped dry cell battery. Coarse adjustment will be made on the latter, intermediate voltages between the $1\frac{1}{2}$ volt "steps" being obtained by operation of the potentiometer, the slides of which should be set so that the contacts are on the point of closing when no signal is being received.

The most satisfactory arrangement is that of "unbiasing" the relay by a current in opposition to the steady anode current. Alternatively the valve should form one link of a bridge.

○ ○ ○ ○

Lost Emission?

A difficulty has arisen with regard to the first L.F. amplifier of my four-valve receiver, for which a negative bias of $1\frac{1}{2}$ volts is recommended. I find, however, that results are distinctly better if the bias is omitted altogether. Do you think that this indicates that something is wrong, and if so, can you make any suggestions?

R. J. S.

Unless your valve is of the special type in which grid current starts late, you can assume with confidence that the L.F. amplifier is not working properly without negative bias. We think it probable that the valve is actually receiving an anode voltage very much less than is required; assuming other valves in the set to be functioning normally, this is probably due to an extremely high resistance in its anode circuit. Alternatively, the valve may have lost its emission.

The Wireless World

AND
RADIO REVIEW
(16th Year of Publication)

No. 464.

WEDNESDAY, JULY 18TH, 1928.

VOL. XXIII, No. 3.

Editor: HUGH S. POCOCK.

Assistant Editor: F. H. HAYNES.

Editorial Offices: 116-117, FLEET STREET, LONDON, E.C.4.

Advertising Telephone: City 9472 (5 lines).

Advertising and Publishing Offices:

DORSET HOUSE, TUDOR STREET, LONDON, E.C.4.

Telephone: City 2847 (13 lines). Telegrams. "Ethaworld, Fleet, London."

COVENTRY Hertford Street.

Telegrams "Cyclist, Coventry." Telephone 6210 Coventry

BIRMINGHAM: Guildhall Buildings, Navigation Street

Telegrams "Autopress, Birmingham." Telephone 2970 and 2971 Midlan t.

MANCHESTER: 260, Deansgate.

Telegrams "Life, Manchester." Telephone 5970 City 54 lines.

Subscription Rates: Home, 17s. 4d.; Canada, 17s. 4d.;
other countries abroad, 19s. 6d. per annum.

As many of the circuits and apparatus described in these pages are covered by patents, readers are advised, before making use of them, to satisfy themselves that they would not be infringing patents.

CONTENTS OF THIS ISSUE.

	PAGE
EDITORIAL VIEWS	59
D.C.5. BY A. L. M. SOWERBY	60
A NEW AERIAL COUPLING. BY F. M. COLEBROOK	65
BROADCAST RECEIVERS: THE ADVANCE THREE-VALVE PORTABLE	68
CURRENT TOPICS	69
NEW APPARATUS	71
PROGRAMMES FROM ABROAD	73
THE OUTPUT STAGE AND THE PENTODE: PART II. BY N. W. MCLACHLAN	77
ARMCHAIR WIRELESS. BY "RADIOPHARE"	81
USEFUL DATA CHARTS: NO. 2	82
NEWS FROM THE CLUBS	84
BROADCAST BREVITIES	85
LETTERS TO THE EDITOR	86
READERS' PROBLEMS	88

PROGRESS.

LOOKING back on the sequence of receiver designs which have been created since the start of broadcasting, we see how the modern receiver has been developed, and readily observe each of the important steps which have been made and are now accepted as everyday practice. Over this time one remembers those periods of little progress when, while fully appreciating the failings of the apparatus to hand, it appeared that finality had almost been reached. From the point of view of the amateur whose interest lives upon progress, it appeared that, early in the present year, the field of radio development had been exploited to the full. The acceptance of this idea led to the speculation that a thinning in the ranks of the radio enthusiasts would come about, and that the building of apparatus for the hobby interest which is derived would decline. Reception appeared to be tolerably good within the limitations of the apparatus to hand, and no immediate progress could be predicted.

Contrary to this point of view, new and far-reaching developments of considerable interest to the amateur have

been created, and rather than a situation of lack of development coming about, the enthusiast is almost faced with difficulty in keeping up to date owing to far-reaching effects of the developments of the past few months. During this time we have witnessed the arrival of the moving-coil loud speaker, setting an entirely new standard in the quality of reproduction of broadcast reception. As a result of its introduction, a better understanding of the functioning of circuits and apparatus has resulted, so that in the operation of valves the amateur reasons in terms of impedance and grid-voltage swing, a marked advancement from the days when the effects of incorrectly operating a valve caused no observable change in the results. In an endeavour to maintain quality, a careful examination of valve characteristic curves has become essential, and correspondence reveals that a large number of readers have applied themselves to gaining an understanding of the full significance of valve characteristics.

Next, the anode feed scheme for avoiding back-coupling in multi-valve receivers has become a recognised practice. Attention to wiring methods by way of suitably running leads in pairs to avoid stray inductive capacity and resistance coupling is now of importance, and the conditions have been carefully analysed.

Each of these developments as they arose were considered to be of first importance, and investigation work was undertaken so that the reader might be well acquainted with the advantages which they offered.

The Revolutionary Pentode.

The multi-electrode valve, in its first form as the screened grid H.F. valve and more recently as the pentode, will, when it becomes available, result in a drastic modification of our present circuits, and many new receiver designs may be forthcoming of remarkable performance compared with our present-day standard.

In addition to pure radio development, foundations for a new field of experiment have been definitely laid in the direction of picture transmission. Apparatus is now available which has proved itself by demonstration to fulfil the purpose for which it has been designed, and its appearance shortly on the market will add to the pleasure of experimental work. Many promises have been made that television transmissions will be undertaken in the early autumn, and it is commonly thought that apparatus will be available for the reception of moving pictures as an adjunct to the broadcast receiver. A technical explanation of a successful system is not yet available for the enlightenment of readers, and neither can the sparse information to hand afford an opportunity for serious and interesting experiment.



A Batteryless Receiver for D.C. Mains.

By A. L. M. SOWERBY, M.Sc.

DURING the last two years or so there has been a tendency to make more and more use of the public supply mains for providing the energy necessary to drive a wireless receiver. Up till very recently this use of the mains had been restricted almost entirely to the provision of high-tension current, the accumulator still being retained for lighting the filaments of the valves.

Where A.C. mains are available, it is now possible to do away not only with the H.T. battery, but with the accumulator as well by employing valves with indirectly heated cathodes, using a transformer to step down the supply voltage to the four volts or so which the heaters of these valves are designed to take. The valve makers have not yet offered us a similar solution to the problem of filament heating from D.C. mains, so that if we wish to dispense with the filament accumulator and heat our valves from such mains we must perforce make use of valves of the ordinary type.

The D.C. Mains Problem.

In attempting to do this two difficulties at once crop up. To begin with, valve filaments are rated for two, four, or six volts, while the mains generally provide a voltage of from two hundred to two hundred and fifty. It is therefore necessary to pass the filament current through external resistances of some kind in order that, at the current required, the unwanted volts shall be dropped across these resistances. The problem is not difficult, of course, for a knowledge of Ohm's law¹ provides all the necessary information, but we are faced with the fact that we have to draw far more power (in watts, calculated by multiplying mains voltage by current flowing) from the mains than we can make use of in the valve filaments. The excess of power drawn from the mains over the amount actually required is expended in heating these resistances, and we have therefore to provide means for dissipating this heat so that it cannot damage the receiver, and, to add insult to injury, these superfluous watts account for the bulk of the cost of running the set.

The second difficulty is to be found in the fact that the mains do not provide a steady voltage, but one

that is continually and rapidly varying at an audible frequency, with the result that a very loud hum is produced in the loud speaker. Nor is it possible, without employing very large and very expensive chokes, to smooth the filament supply sufficiently to remove this hum, for the comparatively large value of current that is required would result in the saturation of the core of any choke normally used for wireless purposes.

Field Winding as Choke-Resistance.

It occurred to the writer that the necessary monster choke might be found in the field magnet of a moving-coil speaker, and that this might, therefore, be pressed into service for smoothing the filament current. Admittedly, the designer of the loud speaker intended the iron to be somewhere near saturation, in order to make the magnetic flux across the gap as great as possible, but fortunately for our present intentions this aim is not achieved except in field magnets wound for low voltages, as will be seen from an examination of the figures for the ampere turns obtained that have already been published in this journal.² Further, it will be found on reference to the table on page 389 in the article mentioned that the usual dimensions of a loud speaker magnet enable us to provide a winding which will pass a current of 0.1 ampere with a potential difference of 150 volts across its windings; the coil in question is the last but one in the table, and consists of 19,000 turns of 34 S.C.C. copper wire, giving a resistance of 1,500 ohms.

The introduction of this field winding into the filament circuit involves two limitations; the valves we choose must have their filaments connected in series and not in parallel, and they must all be of the 0.1 ampere type. Whether they are designed for two, four, or six volts does not, of course, matter in the least. If we are willing to accept these limitations, we shall find that the field winding not only acts as a choke to reduce ripple, but, in addition, takes the place of the resistances suggested above as necessary to cut down the voltage of the mains to that required by the valves. In serving this dual purpose it is, incidentally, energised, and if provided with the usual moving coil and paper

¹ For a discussion of Ohm's Law, see *The Wireless World*, March 28th, 1928, p. 341.

² *The Wireless World*, September 28th, 1927, p. 386.

D.C. 5.—

cone will still fulfil with undiminished excellence its normal rôle of loud speaker.

The adoption of this device has rendered possible the design of the receiver which is the subject of this article, and in which no concessions whatever have been made in design on account of the use of mains feed to the filaments. It cannot, however, be too strongly emphasised that any attempt to use this receiver without either a loud speaker magnet of somewhere near the correct winding, or else a very heavily built and robust choke of similar characteristics in series with the filaments will inevitably lead to complete failure. Even with this winding in use there is a small residue of hum, audible during the intervals of the programme, though not sufficiently so to be a source of annoyance to any normal listener. Without it the hum rises to a roar which must be heard to be appreciated. Any who may wish to use an "all-mains" set operated by direct current with other types of speaker are referred to the description of

so low that the local station monopolises the entire tuning range. Those who live in the immediate neighbourhood of a powerful transmitter, or who have found by experience that they need three tuned circuits to give them the selectivity that they require, will be well advised to add a loose-coupler as part of the receiver. *The Wireless World* selectivity unit,⁴ for example, might readily be incorporated, and in adding such an extra circuit there need be no fear of enhancing the difficulties inseparable from the "all-mains" construction.

The Screened Grid H.F. Coupling.

The high-frequency stage was designed round the valve. The only available screened valve to operate on a filament current of 0.1 ampere is the Cossor 210-type screened valve, and this was accordingly used. This has an exceedingly high anode impedance, of the order of one to two megohms, so that the tuned anode circuit had to be adopted. In spite of the fact that the amplification factor is also very high, the useful ampli-

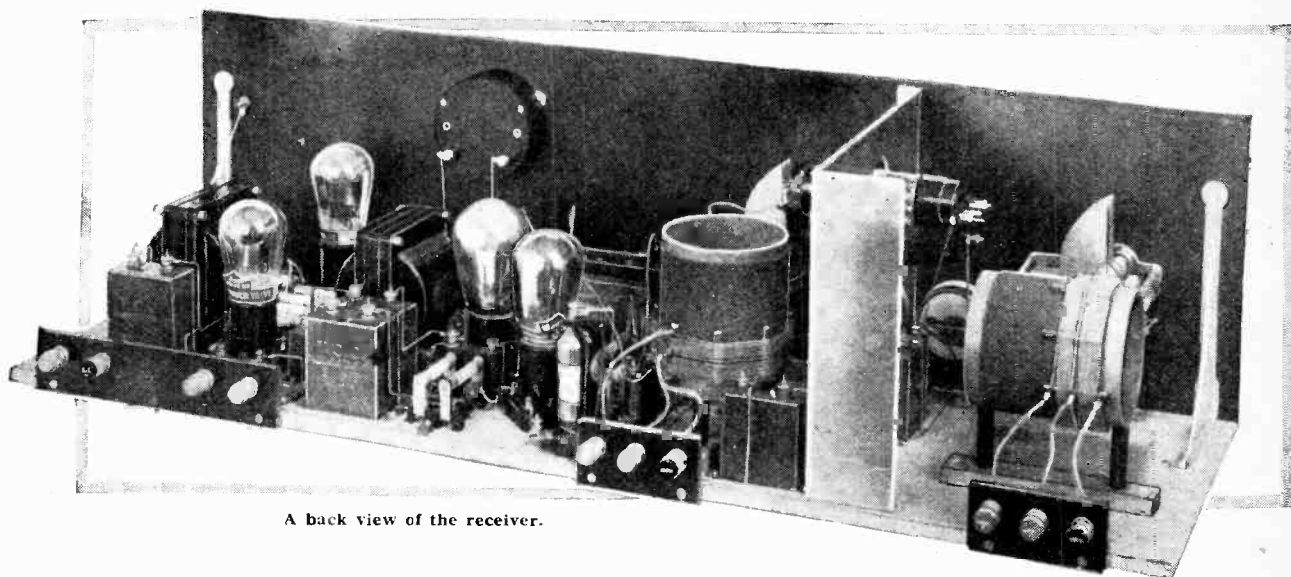

A back view of the receiver.

a receiver using a crystal rectifier which appeared recently in these pages.³

Range and Selectivity.

The receiver which has been evolved in conformity with the limitation as to valves already mentioned is summarised in the circuit diagram which accompanies this article. It will be observed that a single stage of high-frequency amplification, employing a screened-grid valve, has been incorporated, and that this is used in conjunction with an anode-bend rectifier. Such an arrangement, in the absence of reaction, does not give the utmost range; but the receiver is capable, when used with a normal aerial, of picking up at good strength all stations whose programmes are sufficiently free from interference to provide acceptable entertainment.

The selectivity is approximately that normally associated with two tuned circuits, being neither so high that tuning can only be accomplished by an expert, nor

ification attained with such a valve is quite small unless a really efficient coil, of very low high-frequency resistance, is used to couple it to the succeeding stage. In consequence, it was decided to use in this position a coil wound with Litzendraht, even in face of the fact that such a coil tunes sharply enough to introduce some loss of the side bands carrying the high notes. Both this coil and that in the aerial circuit are, therefore, standard "Everyman Four" aerial-grid transformers, the primary on the coil used as intervalve coupling being ignored when the high-frequency stage is in use.

The voltage for the screening grid of the valve is provided in a manner not usually adopted for this purpose. In place of a potential divider to break down the normal 150 volts at which the anode current is supplied to the 80 volts or so which the screening grid requires, a series resistance of the grid leak pattern is employed. This arrangement is perfectly satisfactory when once the right value has been found for this series resistance, but as

³ *The Wireless World*, March 28th, 1928, p. 350.

⁴ *The Wireless World*, April 25th, 1928, p. 434

LIST OF PARTS.

- 1 Baseboard, 30 × 9.
- 1 Ebonite panel, 30 × 8 × 1.
- 2 Parolin tubes, 3in. × 3 1/4in.
- 40 Yards Litz wire (P. Ormiston & Sons) (or 2 standard WIRELESS WORLD aerial circuit H.F. transformers).
- 2 Log. condensers, 0.00033 mfd. (Ormond).
- 2 Friction control dials (Ormond).
- 1 Fixed condenser, 0.1 mfd. (T.C.C.).
- 1 Fixed condenser, 0.0003 mfd. (T.C.C.).
- 1 Fixed condenser, 0.0001 mfd. (T.C.C.).
- 3 Fixed condensers, 0.005 mfd. (T.C.C.).
- 4 Fixed condensers, 2 mfd. (T.C.C.).
- 2 Potentiometers, 400 ohms (Igranic Patent).
- 1 50-ohm Rheostat for conversion to potentiometer (Igranic Patent).
- 3 Vacuum anode resistances, 250,000 ohms (Ediswan).
- 1 Vacuum anode resistance for screen voltage control.

- 1 Vacuum anode resistance, 80,000 ohms (Ediswan).
- 1 Vacuum anode resistance, 150,000 ohms (Ediswan).
- 4 Grid leaks, 5 megohms (Ediswan).
- 1 Transformer, A.F., 3 1/2 : 1 (Ferranti).
- 1 Output transformer, OP3c (Ferranti).
- 1 Anode resistance and holder, 50,000 ohms (R. I. & Varley).
- 1 Milliammeter, 0 to 150 (Ferranti No. 4).
- 4 Valve holders, whitehite (Bonroyer-Lowe).
- 1 Screened valve holder (Colvern).
- 10 Grid leak holders. Aermonic dual mounting (Jas. Christie & Sons, Ltd.).
- 1 Pair Cameo brackets (Carrington).
- 1 9-volt grid bias battery (Ripaults).
- 1 Pair grid bias clips (Bulgin).
- 12 N.P. Terminals (Belling Lee).
- 1 Aluminium screen.

In the "List of Parts" included in the description of THE WIRELESS WORLD receivers are detailed the components actually used by the designer, and illustrated in the photographs of the instrument. Where the designer considers it necessary that particular components should be used in preference to others, these components are mentioned in the article itself. In all other cases the constructor can use his discretion as to the choice of components, provided they are of equal quality to those listed and that he takes into consideration in the dimensions and layout of the set any variations in the size of alternative components he may use.

valves vary in their characteristics it will be necessary for each user to find by experiment the exact value required in his particular case. The figure given for this resistance must therefore be regarded not as a definite part of the design of the receiver, but as a starting point for a few minutes' experimenting.

On account of this series resistance, and of the impracticability owing to the series connection of the filaments of varying the filament current in the H.F. valve in a convenient manner, neither of these two factors is available for volume control. This is, therefore, provided by variation of the potential of the inner grid. When this grid is negative to the extent of half a volt or so, the amplification, provided that the screening-grid voltage is normal, will be a maximum. It is reduced when required by making the grid negative beyond this point, and so raising the impedance of the valve to such high values that the amplification yielded becomes but small.

Optional H.F. Stage.

It is not intended that the volume control shall be used when receiving the local station; instead, the aerial and earth leads are moved to a second pair of terminals connected to the primary wound over the coil immediately preceding the detector. By this means it is possible to use one tuned circuit only for reception of the local station, and so to avoid here, where quality is most important, the loss of side bands that inevitably

accompanies the use of more than one tuned circuit of high efficiency. The one tuned circuit that remains is quite sufficiently damped by the presence of the aerial and of the H.F. valve, which is left running, to take all reasonable care of the side bands.

The detector valve is, as has been mentioned, intended to be used as an anode detector, although the presence of the grid condenser and leak would perhaps suggest otherwise on first glancing at the circuit diagram. There is, however, a sufficient degree of low-frequency amplification to make the use of the valve as a grid detector quite permissible, while the resistance in its plate circuit automatically adjusts the effective high-tension voltage to suit either mode of use without the need for touching any connection.

There are no features of special interest in connection with the L.F. stage, which is of quite conventional design. In view of the fact that the limitation of filament current to 0.1 ampere prevents the use of output valves with which liberties in the way of excessive high-tension voltages can be taken, it has been thought advisable to provide two output valves in order that the temptation to obtain a little extra strength at the cost of overloading may be reduced.

In the circuit diagram, and in the receiver itself, the two valves for the output stage are connected on the push-pull system, and this mode of connection is to be recommended when either the usual high-resistance

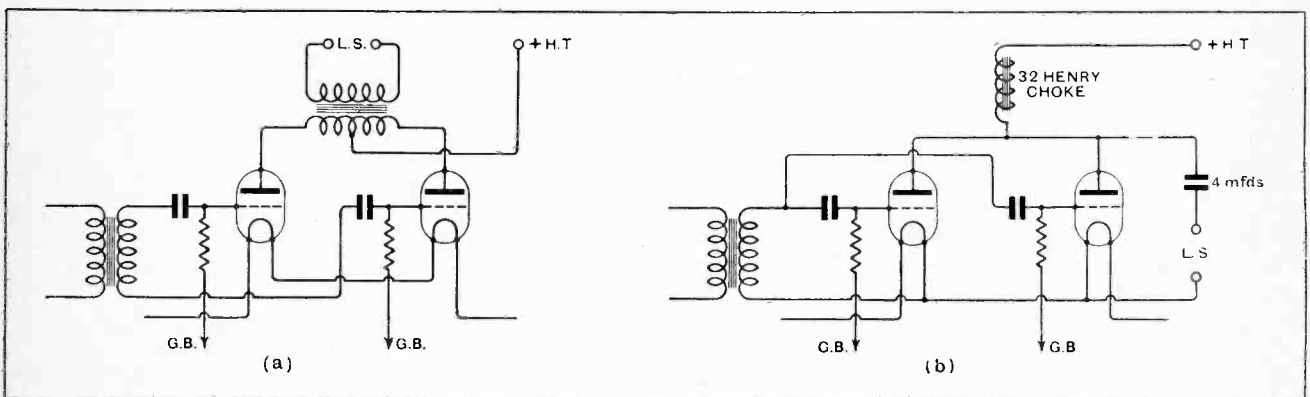

Fig. 1.—Alternative methods of connection of the output stage for either push-pull (a) or parallel connected valves (b).

D.C. 5.—

moving coil, or a standard low-resistance coil with a step-down transformer designed for it, is to be employed in the loud speaker. Since this receiver was designed, however, an article has appeared in these pages⁵ giving the correct coil-windings for use with various combinations of paralleled output valves. If the constructor is willing to wind his own moving coil, there at once arises the alternative possibility of obtaining the required output by connecting the two output valves in parallel. Which of these two alternatives is chosen must be left to the decision of each constructor, but those who contemplate the adoption of push-pull are recommended to study carefully the recent articles on this subject,⁶ in order that they may be completely *au fait* with the methods of dealing with the difficulties that they may possibly encounter.

Push-pull or Parallel Output.

In Fig. 1, (a) and (b) represent the connections of the last stage when using the push-pull and the parallel

from this diagram for the sake of rendering the mode of power supply easier to follow.

It will be observed, first of all, that a high-frequency filter is fitted on the mains side of the circuit. This consists of a special type of low-resistance H.F. choke in each supply main, and a centre earthing device consisting of two condensers in series. Without this arrangement there is considerable danger of the mains acting to some extent as an earth, and so introducing hum into the set through the high-frequency circuits. The chokes and condensers shown effectively put a stop to this particular form of "frightfulness," and so are of material assistance in removing an otherwise obscure source of hum.

Immediately on the receiver side of this filter the positive main branches into two parts. That which runs to the H.T. filter need not be discussed at length; it will suffice to remark that the use of a single filter for all valves makes it necessary to insert a separate resistance capacity filter into each plate-supply lead save the last to prevent "motor boating."

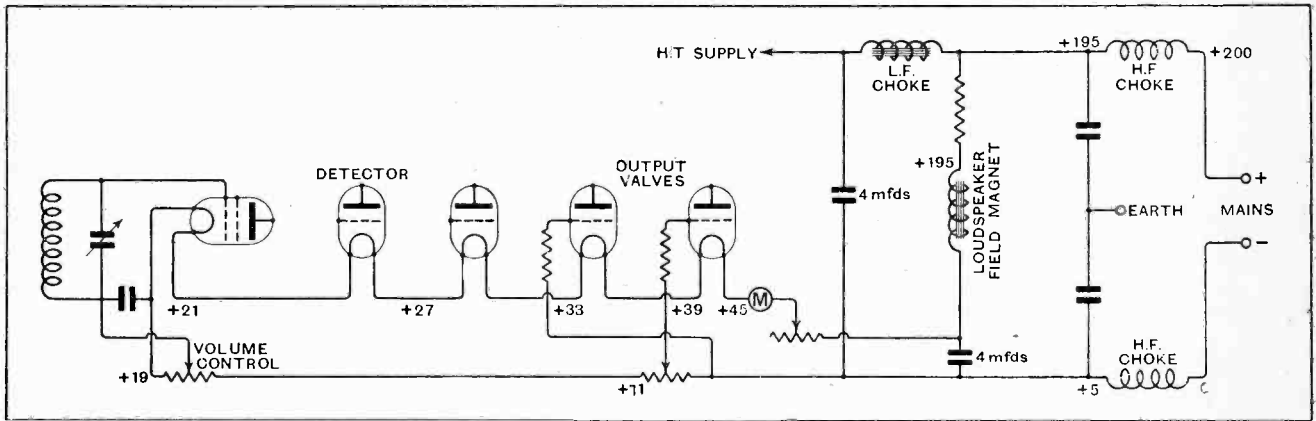

Fig. 2.—How the filament, anode, grid biasing potentials are obtained. Voltage distribution diagram of "all mains" operated receiver.

output respectively; it will be seen that the differences between the two are but small. In the latter case the Ferranti A.F.5 transformer is retained, but instead of connecting one end to each grid, both grids are connected to the same end, the other being earthed on the filament wiring at the junction between the two valves. The special output transformer necessary when using push-pull may be replaced by a choke such as the Pye 32-henry model in conjunction with a 2 mfd. or 4 mfd. feed condenser.

The peculiar use of grid leaks and condensers in the last stage brings us to a consideration of the problems of battery elimination, which, so far, except for the mention of the use of the loud speaker magnet as a filament choke, have been put on one side. Fig. 2 shows the filament and H.T. supply circuits, together with the arrangements for obtaining grid bias from the mains for the high-frequency and output valves; all the purely "wireless" part of the receiver is omitted

The second branch, supplying the filament current, runs first through a small resistance designed to drop the mains voltage to about 200 volts. It should be omitted when the mains have any voltage from 200 to 230, and should have a value of some 250 ohms for 240- or 250-volt mains. About twenty-five yards of 34-gauge Eureka wire, wound on a flat piece of wood, fibre, or slate, and fixed out of the way beneath the eliminator unit, would serve well for this purpose.

Filament Current Control.

After the resistance is connected the loud speaker magnet, followed by a variable resistance of 400 ohms and a meter reading up to 150 milliamps. This variable resistance takes care of temporary variations in the supply voltage and removes the need for providing separately for all the possible voltages from 200 to 250 that lighting mains may possess. The presence of the meter ensures that the filaments shall receive their correct current. The filaments of the five valves in series, and a pair of resistances to provide grid bias, complete the path for direct current. There is also

⁵ *The Wireless World*, June 6th, 1928, p. 601.

⁶ *The Wireless World*, June 6th, 1928, p. 614. and June 13th, 1928, p. 629.

D.C. 5.—

provided a 4 mfd. condenser shunted across the whole filament system with the object of completing the smoothing effect of the loud speaker magnet. This condenser is of material assistance.

Grid Biasing Difficulties.

The voltages assumed in operation by the various points in the filament circuit are given in Fig. 2. The need for the condensers and leaks in the grid circuits of the two output valves arises from the fact, made clear by these figures, that the filaments of the valves are at potentials differing by 6 volts, and must, therefore, also have their grids connected to points 6 volts apart.

The maintenance of the two grids at different D.C. potentials, while supplying them with signal voltage from the same source, can only be achieved in some such manner as that here adopted.

Grid bias for the detector and the L.F. valve may also, thanks to the use of high-value grid leaks, be taken

from the filament circuits without introducing any serious increase of hum, but as these two points, and especially the grid circuit of the detector, are the most critical points in the whole receiver from this point of view, use has been made, as a measure of precaution, of a grid battery.

It is interesting in this connection to note that one of the little points of greatest importance in securing freedom from hum is to keep the detector valve, as far as is practicable, from all other components. Further, it was found absolutely necessary to keep the leads connecting the grid of this valve with the grid condenser and the leak as short as possible; the length of the grid lead *outside* the grid condenser is by comparison of no importance whatever. The substitution of a flat grid condenser, screwed to the baseboard, for the vertical type that has been employed will result in a noticeable increase in the noisiness of the receiver. Attention to these few points is essential if the greatest attainable freedom from hum is required.

(To be concluded.)

AN UNUSUAL FAULT.**Condenser Disconnection that may Merely Impair Efficiency.**

ONE of the most difficult faults to run to earth, though fortunately it is of rare occurrence, is that due to an internal disconnection in a fixed condenser. Should the plates become disconnected from the terminals or soldering tags there is no external indication of the fact, so that the most careful examination of the wiring of the receiver cannot disclose the fault. Though it is easy enough, if proper tests are applied, to detect the short-circuiting of a condenser, there is no possible test that can be made with direct current instruments that can reveal a disconnection of the type described. There are only two ways, in practice, in which such a fault is likely to be detected; one is by reasoning based on the behaviour of the receiver, and the other is by the troublesome process of the substitution of a condenser known to be in good order.

Tracing a Faulty Grid Condenser.

The present writer has encountered this trouble on two occasions; the first was in connection with a portable receiver employing the Hartley circuit. When first built it behaved admirably, but after it had been in use a few weeks it suddenly refused to oscillate or to give any appreciable sign of life. Practically every component in the set was either tested carefully or replaced by one known to be sound, but with no result. After some hours' work in this way the writer drew on paper the circuit of the receiver, and ticked off, one by one, every component that had been shown to be in good working order. At the end of this process the grid condenser alone remained unaccounted for; it had not previously been tested or replaced simply because it was of first-class make and appeared in perfect order, but it was realised that the fault must inevitably lie there. On holding another condenser in parallel with it the receiver made an instant recovery to normal health, so that the presence of the

disconnection was immediately proved. The grid of the valve had been completely isolated from the tuning circuit, so that the absence of signals and of reaction effects was very adequately accounted for.

Similar effects, but of less magnitude, would occur in a receiver employing magnetic reaction by swinging coil if the condenser by-passing the telephones or transformer primary should be similarly faulty. In this case reaction effects would no longer be obtainable, for there would be no path for the high-frequency currents in the plate circuit of the valve, but any station for which reaction was not normally used would be received as usual.

A Difficult Fault if Intermittent.

In the other case referred to above, the condenser in which the disconnection occurred was the shunting condenser across the anode resistance in the plate circuit of an anode rectifier. The effect this time was that signal strength dropped to perhaps one-tenth of its normal value, and the quality deteriorated badly. It is difficult to describe the sound of music under these conditions, but in listening to speech the impression was gathered that the speaker was being throttled, as though he were wearing a collar several sizes too small for him.

Once again a good deal of time was consumed before the fault was located. In both cases the difficulty of diagnosis was enhanced by that fact that the disconnection was intermittent, each of the receivers suddenly recovering once or twice during the process of testing, which gave rise to the belief that the last alteration made had cured the fault.

Results different from those described would follow upon a failure of a fixed condenser in other parts of a set, but enough has been said to draw attention to a form of fault which is both difficult to trace and unlikely to be suspected.

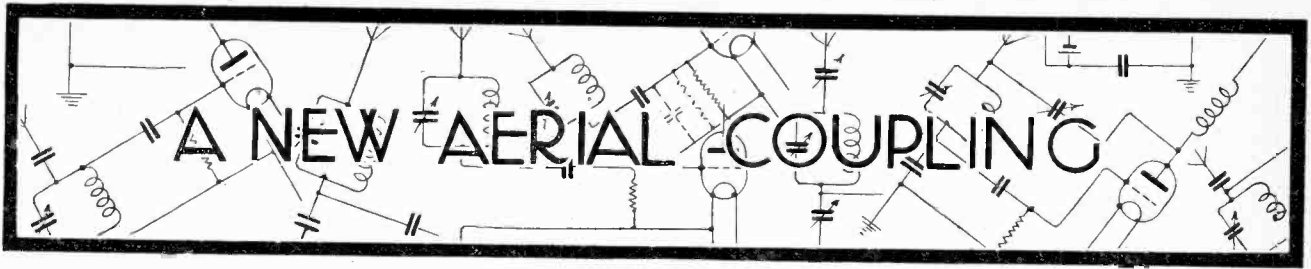

An Explanation of an Interesting Inverted Type of Coupling giving Certain Advantages.

By F. M. COLEBROOK, B.Sc., D.I.C.

IN *The Wireless World* for May 9th there appeared a description of various circuit arrangements for coupling a receiving aerial to the input or grid-filament circuit of a valve. The following is a description of a further arrangement which, though not new in any fundamental sense, is possibly new to many readers of this paper.

The arrangement can be derived, for purposes of explanation, from the very well-known series condenser-coupled system illustrated in Fig. 1 (a).

The diagram shows a condenser and grid leak input connection which is suitable either for rectification or, with a suitable negative potential applied to the end of the grid leak, for high-frequency amplification.

The object of coupling the aerial to the valve through the agency of a tuned inductance-capacity circuit is to convert the comparatively small e.m.f. picked up by the aerial into a relatively large resonant potential difference across the tuned circuit. In the circuit shown in Fig. 1 the resonance condition is established by variation of the parallel tuning condenser C_2 . At

for the operation of the receiver, instead of that across the parallel tuned circuit. The arrangement would then be as shown in Fig. 1 (b).

As a further modification the condenser C_1 can be omitted altogether, giving the arrangement shown in Fig. 1 (c).

It may even be found in some cases (depending on the valve and on the load in its anode circuit) that an increase in signal strength is obtained by omitting the condenser in this way. How can this be explained, for the two circuits of Figs. 1 (b) and 1 (c) appear to be materially different, and one might be excused for thinking that in Fig. 1 (c) a quite new system of tuning and coupling was being used?

The difference is, however, more apparent than real. It must be remembered that at any given frequency of operation the input or grid-filament circuit of a triode valve behaves in effect as though there were a small fixed condenser, in parallel with a fixed resistance connected between the grid and the filament. This fact is now much more generally realised than it used

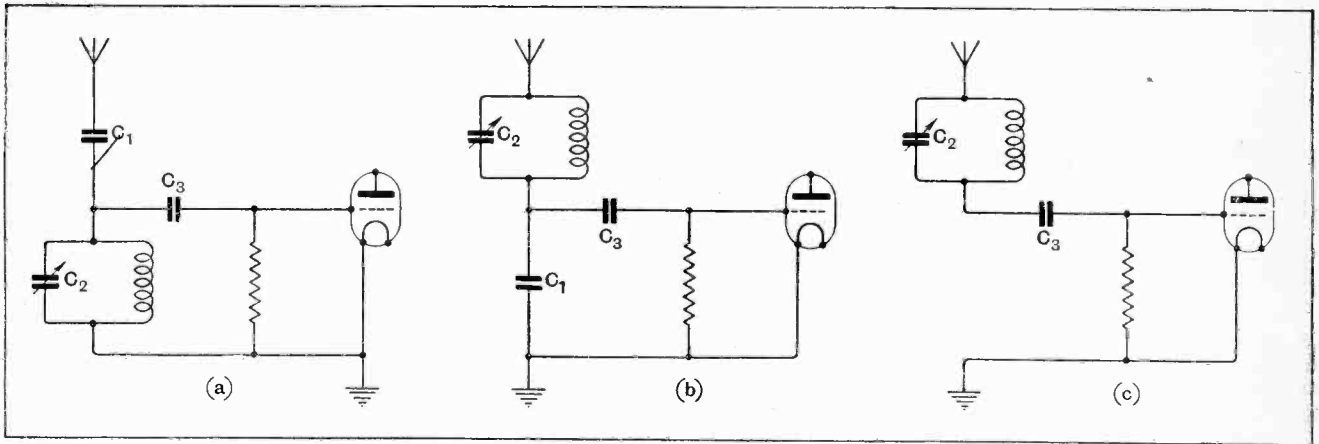

Fig. 1.—(a) Conventional parallel tuned circuit with series aerial condenser. (b) As there is a relatively large potential difference across the condenser C_1 in Fig. 1 (a) at resonance, it is reasonable to suggest transferring the tuned circuit to this point and replacing the original tuned circuit by C_1 . (c) The condenser C_1 of Fig. 1 (b) may be omitted altogether. Under certain conditions the circuit here illustrated may give greater signal strength than that shown in Fig. 1 (b).

resonance there will be a relatively large p.d. across the aerial series condenser C_1 also, comparable in magnitude with that across the tuned circuit, but nearly opposite to it in phase. There is therefore no apparent reason why this latter resonant p.d. should not be utilised

to be, and the important part played by this "input impedance," as it is called, is gradually being appreciated. The actual magnitudes of the shunt capacity and shunt resistance will depend on the valve and on the load in the anode circuit. In general, the shunt

A New Aerial Coupling.—

capacity will be relatively small, say, $30 \mu\mu\text{F}$ or so, but under certain conditions it may be as much as $100 \mu\mu\text{F}$ or more.

If these "effective" elements be included in the picture, shown by dotted lines to distinguish them from the actual elements, the circuit of Fig. 1 (c) becomes as shown in Fig. 2 (a), and in this form it can be seen that the only essential difference between Fig. 1 (c) and Fig. 1 (b) is that in Fig. 1 (c) the condenser C_1 is connected to the grid side of the grid coupling condenser, and since the magnitude of the latter is relatively large this fact makes very little difference.

In actual practice it is preferable not to omit the capacity C_1 , but instead to use in this position a variable condenser of, say, $500 \mu\mu\text{F}$ maximum value. The reason for this is the existence of the shunt resistance component of the input impedance. Even if the anode

increased beyond this point by still further increasing C_1 , and thus reducing in effect the amount of the input shunt resistance which enters into the aerial system. The use of a variable capacity for C_1 thus enables one to control both the sensitivity and selectivity of the system, the most suitable magnitude being found by trial.

Reaction Without Tapped Coil.

The above discussion has left out of account the possibility of employing reaction with this type of coupling, but it is, in fact, very well adapted for the use of that type of reaction control which is now most generally favoured, namely, capacity control. In both the Reinartz and Hartley receiving systems a point of the receiving circuit, of which the alternating potential is comparable in magnitude but opposite in phase to that of the grid, is coupled through a variable

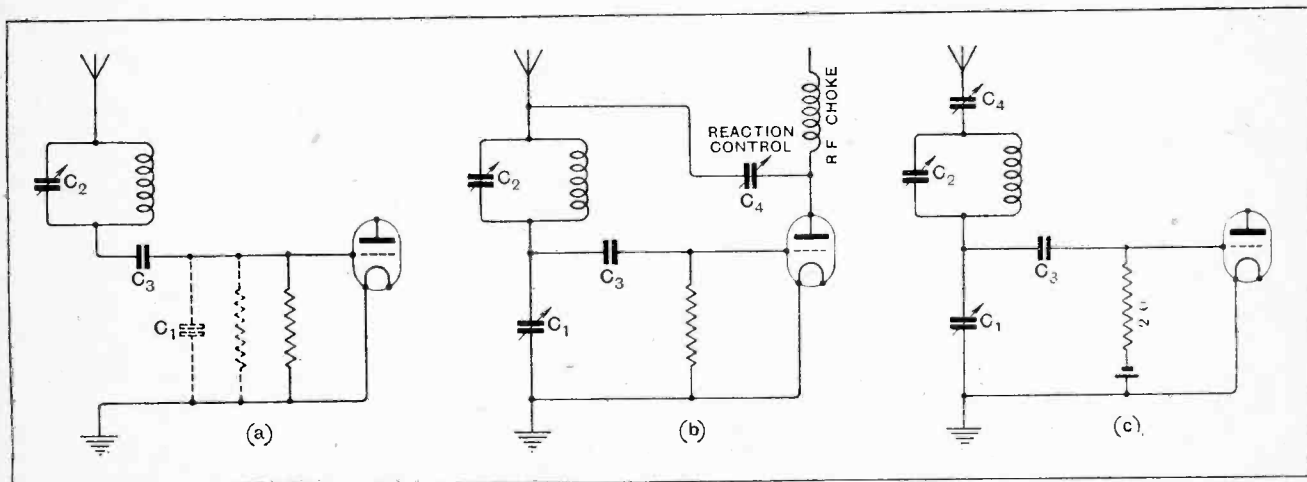

Fig. 2.—(a) The input impedance of a valve may be considered as a condenser shunted by a resistance in parallel with the grid and filament; these are shown in dotted lines. (b) The general type of circuit described in this article is well adapted to capacity control of reaction. (c) The addition of a variable condenser in series with the aerial will give a stability control with relatively large signal intensities.

circuit load is such as to make this large (and correspondingly unimportant, since it is in shunt), it must be remembered that when the valve is being used as a rectifier, with a small positive potential on the grid, there will be an actual grid-filament conductivity due to grid current which is equivalent to a relatively low shunt resistance path (of the order of hundreds of thousands of ohms). Now, whatever type of coupling is used this resistance will tend to increase the effective resistance of the aerial resonant system, reducing both amplitude and selectivity in consequence. But the effective value of this resistance, from the point of view of the aerial resonant system, will depend upon the magnitude of the capacity which is connected across it. As far as amplitude is concerned, an optimum condition can be obtained by variation of C_1 (and of C_2 simultaneously, to restore the tuned condition), and an analysis of the system shows, as might be expected, that in this optimum condition the energy consumed in the input shunt resistance is equal to that consumed in the remainder of the aerial system. The selectivity of the whole system can, however, be

capacity to the anode, with a radio-frequency choke included in the anode circuit. Now, as explained above, the point of connection of the aerial to the parallel tuned circuit fulfils these conditions. Capacity reaction can therefore be obtained as shown in Fig. 2 (b), and will be found to be very effective and smooth in control, both for medium and long wave reception.

The system possesses the advantage that capacity-controlled reaction can be obtained in this way using the simplest type of plug-in coil, without either a centre tapping or any auxiliary winding.

Now, however, one drawback of the system must be pointed out. It is not very suitable for use in a place which is subject to comparatively low frequency interference, e.g., long wave Morse transmission, noise from electric mains, etc. The reason for this is that the grid and filament are connected by a circuit of which the impedance with respect to low-frequency interference is high, whereas an inductive connection between the grid and filament has just the opposite characteristics. This disadvantage applies only to cases in which

A New Aerial Coupling.—

the first valve is a detector, supplying 'phones or a L.F. amplifier. If the first valve is a tuned transformer high-frequency amplifying valve this type of input circuit is quite satisfactory, since low-frequency interference will not get through the H.F. stage.

Stable H.F. Stage.

As the input circuit of a receiver with a tuned H.F. stage, the above system has a further advantage. It is well known that a H.F. stage of this character is inherently unstable, and requires stabilisation by means of a neutrodyne or some similar arrangement. This instability arises from the fact that the input shunt resistance referred to above becomes in effect a negative quantity, introducing "negative damping," i.e., a tendency to oscillate, into the input resonant circuit. Now the shunt capacity C_1 is just as effective in limiting the action of the input shunt resistance whether the latter is positive or negative, and can thus be used to control this tendency to instability. In fact, with this type of input circuit neutroding can be dispensed with if desired, though it is preferable to use C_1 merely as an auxiliary stabilising adjustment, the variation of which becomes in effect a retro-action control.

One further advantage can be claimed in this connection. It is probably a fairly general experience that a

receiver with a H.F. stage gives an altogether excessive response to the local station. Now if C_1 be made large (e.g., all in with a 500 $\mu\mu\text{F}$ variable), the signal strength can be greatly reduced, and at the same time complete stability is assured, even for relatively large signal intensities. If C_1 is made larger, however, practically the full aerial capacity is thrown across the coil, so that for such cases a small fixed condenser (100 $\mu\mu\text{F}$ or less), or, better still, a variable one (500 $\mu\mu\text{F}$), can with advantage be put in series with the aerial, as in Fig. 2 (c).

The fact that additional variable condensers are required for this arrangement is no great drawback, since these are almost the cheapest of wireless components, and the circuit shown is extremely elastic with regard to sensitivity and selectivity.

As to whether this "inverted" type of coupling is better or worse than those customarily employed, the writer hesitates to be dogmatic. He has certainly found it very satisfactory in connection with a receiver with one tuned transformer stage from the point of view of elasticity of manipulation. The fact that plain two terminal coils only are used, without the need for tappings or auxiliary coupling windings, is also a very good feature. It is, in any case, something new for the experimenter to play with, and is described mainly for that reason.

Winding Coil.
(No. 286,047.)

Application date: January 17th, 1927.

The Figure illustrates an unusual method of winding inductances, which is stated to increase their inherent capacity. The formation shown at A is obtained from a single circular loop of wire by twisting it locally at the top and bottom of a diameter. The upper and lower loops are then bent inwards as shown at B, while C is obtained by imposing a figure-of-eight twist on B. The final

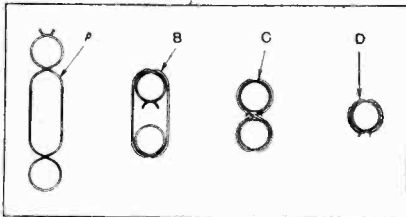

Method of coil winding, composed of folded loops. (No. 286,047.)

shape D is derived by folding the two existing loops of C one over the other. It is claimed that this method of winding ensures an external shielding effect because the external field of the finished coil remains approximately the same as that of the original straight winding.

Patent issued to F. Rogers and E. H. Griffiths.

Four-Electrode Valves.
(No. 285,975.)

Application date: November 23rd, 1926.

A four electrode-valve is constructed so that the portion of the grid G which

SOME RECENT PATENTS.

The following abstracts are prepared, with the permission of the Controller of H.M. Stationery Office, from Specifications obtainable at the Patent Office, 25, Southampton Buildings, London, W.C.2, price 1s. each.

lies between the cathode and the two cylindrical anodes A, A_1 is made of cylindrical mesh than the remainder thereof. The Figure shows such a valve used for introducing reaction with a resistance-coupled circuit, where the magnitude of the coupling-resistance is normally too high to permit of this being done.

The main anode A is connected to the high-tension through a resistance R of 5 megohms, and to the grid of the succeeding valve through a coupling condenser C. The reaction coil L is then inserted in series with the second anode

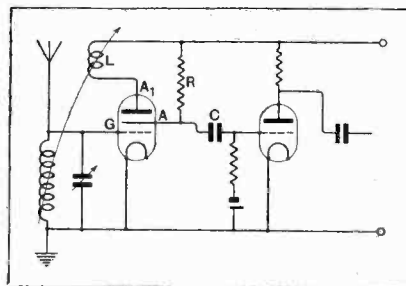

Four electrode valve circuit, including provision for reaction. (No. 285,975.)

A_1 , and back-coupled to the aerial input as shown.

Patent issued to the Edison Swan Electric Co.

Reaction Control.
(No. 286,578.)

Application date: November 15th, 1927.

By using a three-plate condenser, C_1, C_2, C_3 as shown, the value of the high-frequency current flowing in the reaction

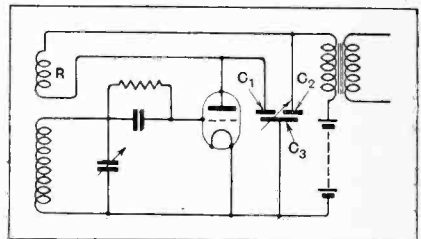

Three-element condenser for reaction control. The parallel shunt capacity across the transformer winding remains constant. (No. 286,578.)

coil R can be controlled without appreciably affecting the tuning of the grid circuit. The vanes C_1, C_2 to which the two ends of the coil R are connected are fixed, whilst the vanes C_3 are movable. Their shape is such that as the capacity coupling between say C_1 and C_2 is increased, that between say C_3 and C_2 is reduced by a corresponding amount, so that the overall shunt capacity of the condenser remains constant for all adjustments. The compound condenser also functions as a constant-capacity path to by-pass high-frequency currents from the low-frequency stages of the set. Patent issued to Igranic Electric Co.

Broadcast Receivers

The
ADVANCE
THREE VALVE
PORTABLE

An Ideal Set
for the
Flat Dweller.

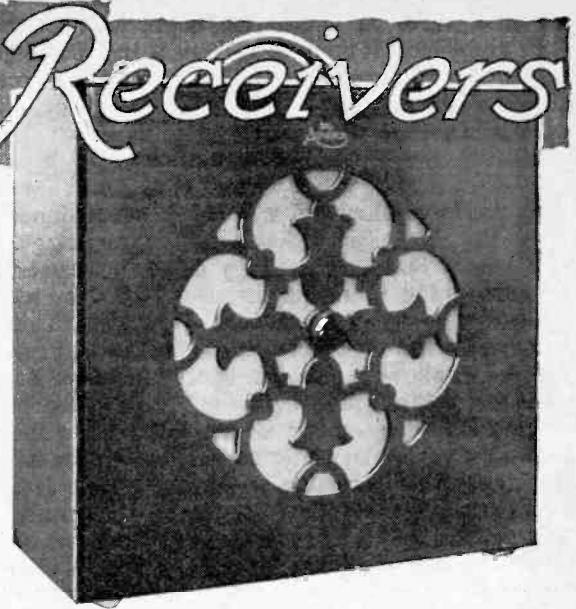

THE self-contained receivers made by Messrs. G. Forster, Carlton House, Lower Regent Street, London, S.W.1, are made in two types—the "Portables," for general use in and out of doors, and the "Transportables," which are more or less restricted to indoor use, but can be easily carried from room to room. The former type is fitted with a leather carrying strap, and the latter with small metal side-handles. There are also minor differences in the cabinet work, but the "works" are essentially the same in both types.

The aim and scope of the series is admirably summed up in the following sentence taken from the illustrated folder issued by the makers: "In designing these 'Advance' 3-valve receivers, we have sought to meet the requirements of those members of the public who require a set which will give pure and undistorted loud-speaker reception from the local station and Daventry 5GB without any trouble, particularly those who do not wish or have not the facilities for erecting an aerial."

The circuit chosen is well calculated to fulfil this purpose. It consists of a frame aerial, covering a waveband of approxi-

mately 250 to 700 metres, feeding into a detector with capacity-controlled reaction and followed by two low-frequency amplifiers. Reaction was a little difficult to control; in the particular set tested there was just about enough "backlash" to prevent that last ounce of sensitivity from being extracted from the use of the reaction coil. When using the set for the purpose for which it is intended, this fault ceases to influence results, for there is no necessity to push reaction to get either 2LO or 5GB within 25 miles of the former station. Selectivity is also sufficient to give complete separation between the two stations in the London area, and even when within a mile or two of Oxford Street, no trouble is experienced on this score if the position permits advantage to be taken of the directive properties of the frame. It is quite obvious from the maker's literature that the set has been designed primarily for the London district, and in particular for flat dwellers in that area. This would account for the lack of provision for the reception of 5XX which usually duplicates the London programme, and is therefore unnecessary to London listeners.

Volume and quality of reproduction are entirely satisfactory, and we were especially impressed with the clear diction of speech. B.T.H. transformers are used to couple the L.F. valves, and the output valve used during the test was a Mullard P.M.2. The loud-speaker is of the cone type with an adjustable movement.

A 108-volt H.T. Grosvenor battery of the A.K.66 type supplies a total current of approximately 8 milliamperes, and should give a service of over 300 working hours. The L.T. supply of 0.35 amp. is drawn from a 2-volt Exide N.S.B. unspillable cell which gives 74 hours' service on a single charge.

The general layout and construction are deserving of special praise. The mahogany cabinet is strongly built and well finished, and yet the weight is not excessive—28lb. complete. The grid bias battery is fitted in an accessible position in a well at the front of the valve compartment. Behind the valves are the main tuning dials, which are actuated from the outside of the set by two small knobs through a slow-motion friction device. It is necessary to open the back and look behind the valves to see the dial settings, but having once familiarised oneself with the "feel" of the controls, reference to the dial settings of the alternative stations is unnecessary.

The price of both the "Portable" and the "Transportable" models is £18 18s., inclusive of royalties, and ready for immediate use. A 6-in. hall-bearing turntable may be fitted as an extra for 8s. 6d., and a waterproof canvas cover for the "Portable" costs 10s. There are two special models, one in figured walnut at 21 guineas, and the other in jap lacquered finish at 23 guineas. Both these models are available in portable or transportable form.



Interior of the "Advance" portable, showing tuning dials and readily accessible grid battery.

CURRENT

TOPICS



HIND

Events of the Week

CHANGES AT EIFFEL TOWER.

FL, the famous Eiffel Tower wireless station, will probably undergo extensive alterations in the near future, including a power increase to 100 kilowatts.

o o o o

MAKE A NOTE OF THE DATE.

Mr. Samuel Izenstark, described as "the pioneer of wireless manufacture in America," prophesied last week that television sets will be installed in 14,000,000 homes in America within the next twelve months.

o o o o

OZONISED MUSIC.

The *Daily Mail* musical yacht *Ceto*, equipped with a loud speaker and broadcast receiver, is now touring the south coast resorts. The B.B.C. programmes are reproduced for the benefit of holiday-makers on the beach.

o o o o

THE BID FOR POWER.

The steady growth in the power of broadcasting stations is not confined to Europe. The General Electric Company of New York has stated that it is hoped to increase the power of WGY, Schenectady, next autumn to 200 kilowatts.

So our next problem will be: "How to cut out America."

o o o o

PLEA FOR WEEK-END WIRELESS FROM 5SW.

A correspondent in British Guiana writes: "I receive 5SW regularly except on Saturdays and Sundays, which is a great pity for, on Saturdays, when the workers are given a half-day off, we have no programme to look forward to except that of station WGY, Schenectady."

Our correspondent's complaint, believed to be the first of its kind from a Britisher overseas, was brought to the notice of the B.B.C. "It is true," said a B.B.C. official, "that 5SW transmits only from Monday to Friday, but it must be remembered that the station is purely experimental; it is not a service station, and, after all, Monday to Friday is a working week."

A 19

in Brief Review.

NEW H.F. UNIT.

Owners of Cossor "Melody Maker" receivers will be interested to learn that Messrs. Peto-Scott have designed and are ready to supply parts for a screened grid H.F. unit specially applicable to that type of receiver.

o o o o

B.B.C. AND TELEVISION.

The B.B.C. made its first official announcement on television on Wednesday last. "In order that listeners may not suffer disappointment by anticipating the possibility of seeing as well as hearing performances," ran the statement, "the B.B.C. announces that it has not so far been approached with apparatus of so practical a nature as, in the opinion of the corporation, to make television possible on a service basis."

The officials at Savoy Hill decline to make further observations on television at the present time.

o o o o

100 STATIONS ON SINGLE WAVELENGTH.

A rather ambitious plan for solving the problem of mutual interference between broadcasting stations has been placed before the U.S. Federal Radio Commission by Mr. Paul M. Titus, of New York, who suggests the simultaneous operation of a large number of stations on a single wavelength. Possibly Mr. Titus is unaware of the comparative failure which has marked similar schemes in Europe, even when carried out on a small scale, for he considers it feasible to place 100 stations on the same frequency. He would control such a system from a centrally located "frequency manufacturing plant," having "perfected a means of controlling the frequencies of a plurality of stations in such a manner that it is now possible to hold any given number of them to their assignment within five or six kilocycles." The writer is naturally reticent at present regarding the means employed.

Mr. Titus is forming an organization to be known as the Continental Broadcasting Corporation with the object of broadcasting commercial programmes for good-will or advertising purposes.

THE LAST WORD.

Among the best people in America the wireless listener is now known as a "dialer."

o o o o

MORE LISTENERS IN SWEDEN.

At the end of May the number of licensed listeners in Sweden was 363,863, as compared with 360,059 on April 30th.

o o o o

A SATISFIED LISTENER

A new form of compliment paid to the B.B.C. was referred to by Miss M. Aspinall, matron of the Stanley Hospital, Liverpool, at a recent conference on broadcasting. A woman patient had said to her: "We do so like the musical programmes. They send us to sleep."

o o o o

HULL STATION DIRECTOR.

Captain C. G. Daley, director of the B.B.C. station at Hull, is leaving this week to take up an appointment at Savoy Hill. Captain Daley succeeded Mr. Leslie Page as station director eighteen months ago, when Mr. Page was appointed director of the Bombay station.

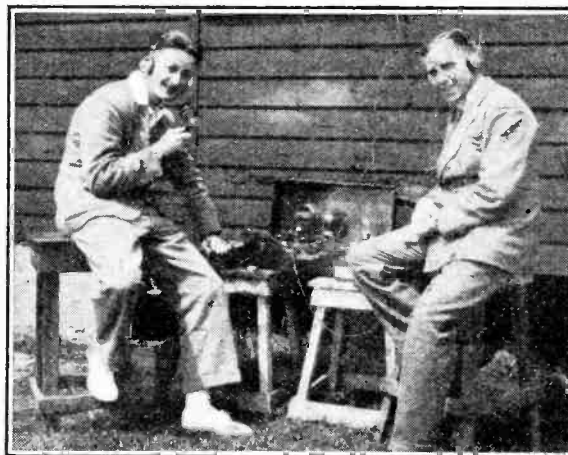

THAT FIELD DAY FEELING. Members of the Southend and District Radio Society with their attaché case transmitter and receiver on a recent field day.

CLOCK SYNCHRONISING BY WIRELESS.

The synchronisation of clocks by wireless is a natural development upon the older and widely used method of synchronisation by land line, but up to the present few attempts appear to have been made to use wireless for this purpose. An interesting device is, however, in use

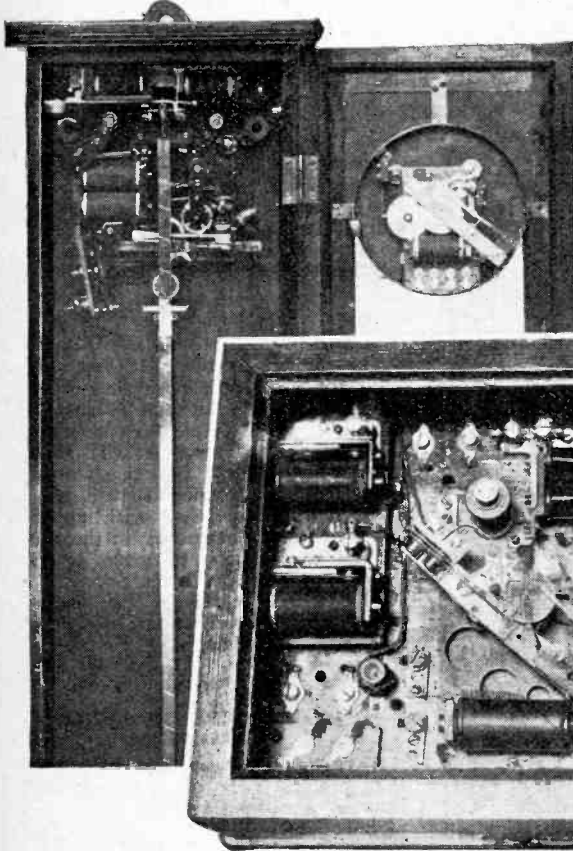

TIME - KEEPING BY WIRELESS. On the left is the Pulsynetic clock, described on this page, which is daily synchronised with the Daventry time signal. The near view shows the "See-Saw" synchroniser which controls the speed of the pendulum.

at the Leicester residence of Mr. Alfred E. Ball, who is head of the electric clock department of Messrs. Gent and Co., Ltd. Mr. Ball has applied his invention to the "Pul-syn-etic" system of electric clocks manufactured by that firm.

Eight electric clocks are at present controlled by the device, which operates on the well-known six-dot Greenwich time signal broadcast from Daventry. A four-valve receiver is employed with a small aerial permanently tuned to 5XX. The set is switched on automatically by one of the impulse clocks some seconds before the 10.30 a.m. time signal. The last dot impulse, in addition to effecting synchronisation, automatically switches off the valves, while an electrical switch automatically earths the aerial except for the brief period when the valves are lit.

The installation has operated without any attention whatever for the last six months, and the maximum error recorded has not exceeded one second fast or slow.

"BROADCASTING" WITH 5 WATTS.

"What is the lowest reasonable power for a broadcasting station?" was a question discussed recently by the Transmitter Section of the American National Electrical Manufacturers' Association Radio Division. It was finally decided that 0.5 kW. represented the limit of practicability.

WIRELESS AT WESTMINSTER.

From Our Parliamentary Correspondent.

P.M.G. on Broadcasting.

Sir William Mitchell-Thomson, the Postmaster-General, in introducing the Post Office Estimates in the House of Commons last week, made an important statement in regard to broadcasting. He said that, on the whole, the institution of the British Broadcasting Corporation, which he had recommended to the House with a little trepidation, had justified itself. In ordinary matters of detail the governors of the corporation were absolute masters in their own house. He did not interfere with their absolute freedom of conducting their business. All he had to say with regard to programme criticism was that any remarks which members had to make on the subject would be faithfully conveyed by him to the governors of the corporation.

o o o o

Regional Scheme of Empire Broadcasting.

As regarded matters of general policy, for which he took responsibility, the most important was the regional scheme. The corporation applied last February for authority to begin this system by working a two-wave high-power station at Brookman's Park, near Potters Bar, in substitution for 2LO. He had authorised them to proceed with the erection of the station. It was expected that it would be completed some time next summer. On June 14th the corporation applied for general permission to proceed with the preliminary steps for twin-wave high-power stations at Manchester, Glasgow, and Cardiff, and for a single-wave high-power station at Belfast. That application was having consideration at the present moment. He anticipated that he would be in a position to give permission almost at once. As regarded Empire broadcasting he had authorised the British Broadcasting Corporation to conduct experiments in short-wave broadcast to the outlying parts of the British Empire, and those experiments were still in progress.

o o o o

Licences.

As to licences, the total number of wireless receiving licences in force on June 30th last was approximately as follows: Paid licences, 2,506,300; free licences for the blind, 12,772; total 2,519,072. The number on the corresponding date last year was 2,307,678. There had thus been an increase of 211,394 during the last 12 months, or over 9 per cent. The receipts from the licences were divisible in the following proportions: Receipts, £1,253,150; to the B.B.C., £898,804; 12½ per cent. to the Post Office for the cost of collection, £156,644; balance retained by the Exchequer, £197,702.

o o o o

Programmes Criticised.

In the debate which followed, the B.B.C. programmes were severely criticised. Mr. Macpherson said that the public found the programmes intolerably didactic and usually highbrow.

▲ 20

That this view is not abundantly shared is evident from a study of the list of so-called broadcasting stations flourishing in the U.S. Numbers of stations are working on 50 watts, while a few manage with 30 and 25 watts. Until recently Mr. William S. Pote, of Chelsea, Mass., spread the good news with only 15 watts, but, from a perusal of the latest lists it seems that he has closed down, possibly due to annoyance at the discovery that he was being outdone by Mr. Peter Prinz, of Jamaica, N.Y., broadcasting on 10 watts. If Mr. Prinz follows his more potent rival, it may be due to the success of the Home Cut Glass and China Co., of Carbondale, Pa., which entertains its public with 5 watts.

o o o o

BURNDIPT RECONSTRUCTION.

We learn that the terms of the reconstruction of Burndipt Wireless, Ltd., have been finally agreed. Satisfactory underwriting arrangements have been made for the new issue.

WIRELESS WORLD

LABORATORY TESTS

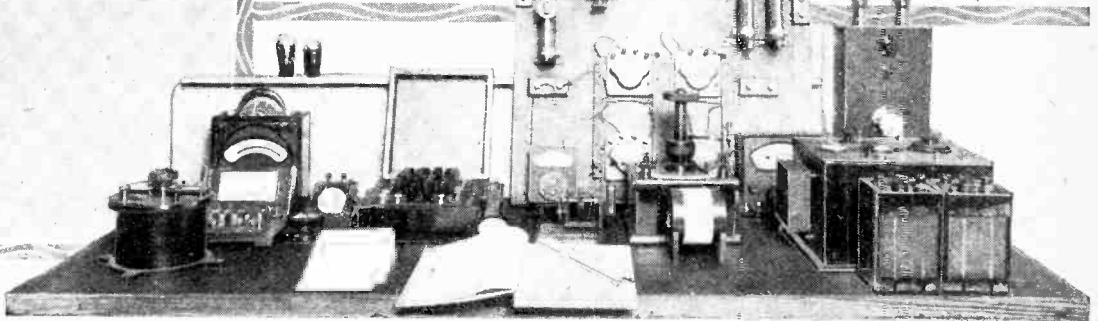

A Review of Manufacturers' Recent Products.

PHILIPS LIGHTNING ARRESTER.

The Philips lightning arrester gives adequate protection to the receiving set without the necessity for switching of any kind. It is fitted outside the house preferably on a bracket attached to the wall, and a direct lead to earth is taken from the lower terminal. The

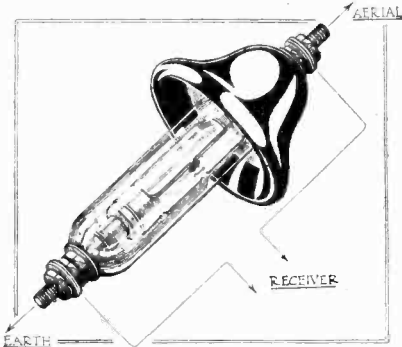

Philips lightning arrester.

aerial and receiver leads are connected as shown in the sketch.

The container consists of a thick glass tube which screws into the underside of a glazed porcelain cowl, an arrangement which gives perfect weather protection with high surface insulation. Inside the container is a double safety gap consisting of a glass tube fitted with inert gas and an adjustable gap with saw-edge copper electrodes. The outer copper gap effectively deals with stray discharges, while the enclosed gap by-passes the smaller E.M.F.s induced by distant lightning flashes. Normally the resistance of the enclosed gas is infinite, but when a certain threshold voltage is reached a discharge takes place through the gas, thus releasing to earth any charge which may have accumulated on the aerial wire.

The price of this component, which is obtainable from Messrs. Philips Lamps, Ltd., 145, Charing Cross Road, London, W.C.2, is 9s. 6d.

A FABRIC-COVERED CABINET.

As a change from the familiar French polish finish, fabric covering is an attractive alternative. Messrs. J. Hyatt and Co., Ltd., have specialised in this type of finish, and now market a wide range of cabinet sizes covered either in black or antique brown leather cloth. The cabinet illustrated is suitable for the Corsor Melody Maker, and costs 15s. The covering lies perfectly flat and is tastefully grained.

o o o o

ORMOND CABINET LOUD SPEAKER.

The four-pole balanced armature movement of this loud speaker is sensitive and will handle considerable volume—more than sufficient for the average room—without chattering. Quality of reproduction is good, and during the time it has been on test has never failed to provoke favourable comments from chance listeners who happened to hear it in passing.

The cabinet is acoustically open on both sides, and there is no detectable difference either in volume or colouring be-

tween the output of each side. The cabinet work is of high quality and

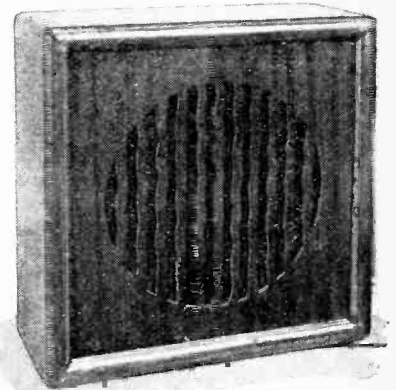

Ormond cabinet loud speaker with balanced armature movement.

finish, and the price is £4 4s. This instrument cannot fail to add to the high reputation of Ormond products.

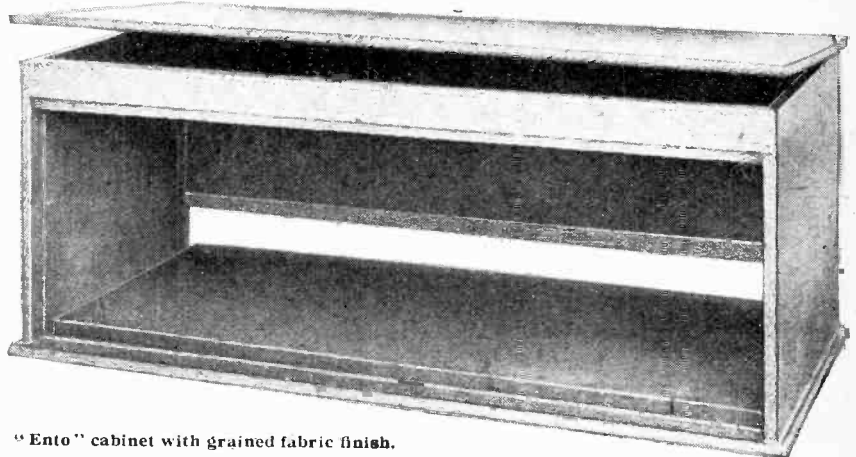

"Ento" cabinet with grained fabric finish.

SURE-A-LITE "SUPRA" BATTERY.

Sure-a-lite batteries are made by The Battery Company, 92, Hurst Street, Birmingham, in three sizes designated respectively "Supra," "Giant" and "Fower." The battery under review is the smallest of the three but even so the cells are larger than is usual in batteries of similar type and price.

The general form of the discharge curve does not differ greatly from normal and a useful life of 300 to 350 working hours is indicated. The curve is, however, remarkably free from minor irregularities



"Supra" type of Sure-a-lite battery.

and it would appear that the battery could be drained right out if fresh cells are added from time to time to keep the voltage normal.

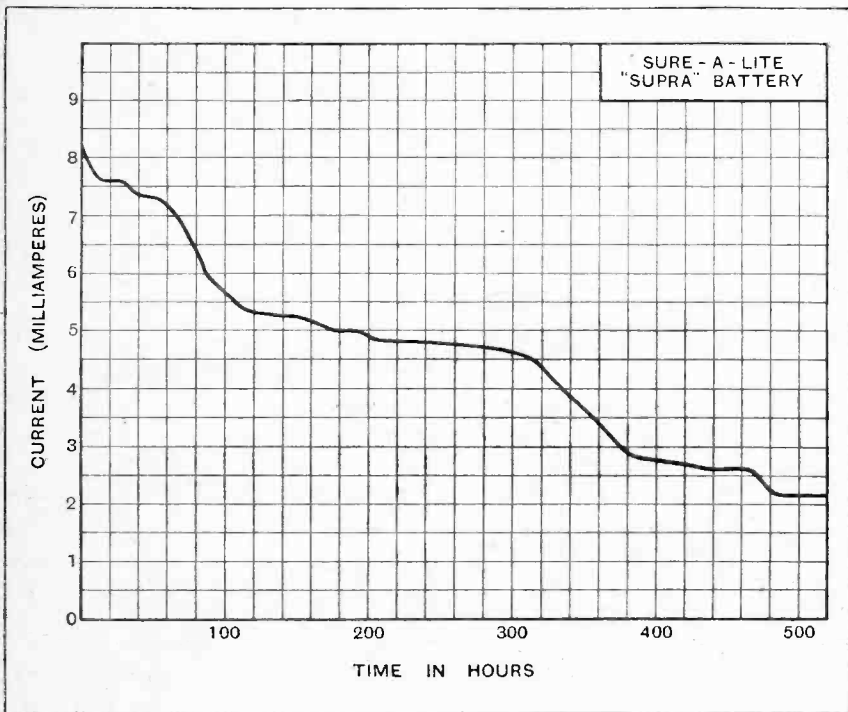

Discharge curve for the 66-volt Sure-a-lite "Supra" battery.

"BERCLIF" ANODE FEED RESISTANCES.

To meet the requirements of those who wish to experiment with anode feed resistances in existing receivers, Messrs.

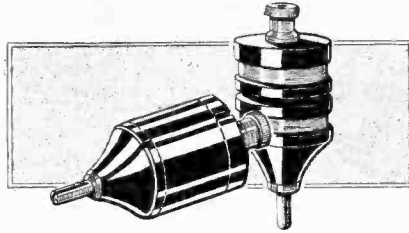

"Berclif" anode feed resistances.

Simmonds Bros., Shireland Road, Smethwick, Staffs, have produced a special type of resistance in the form of a H.T. wander plug. The wire is wound non-inductively in a slotted ebonite former, and the normal value is 20,000 ohms; other values can be supplied to meet individual requirements. In applying this scheme no structural alterations are necessary in the receiver, provided (1) that each valve is supplied independently from a separate H.T.+ terminal, and (2) that each H.T.+ terminal is already by-passed to L.T.— by a large-capacity reservoir condenser. Assuming that the receiver is built on these lines, the "Berclif" resistances can be applied externally, and there is ample scope for experiment in testing out various values of resistance in accordance with the information given in previous articles in this journal. The price of each unit is 5s. 6d.

EDWARDS UNSPILLABLE ACCUMULATOR.

The design of unspillable accumulators for use in attaché-case portables presents a difficult problem in that the set is generally worked in a plane at right angles to that in which it is carried. Unless glass wool is used to hold the electrolyte, the plates will not be always in contact with the acid; but the use of glass wool has disadvantages, otherwise its adoption would be universal.

In the type E.L.2 accumulator made by Messrs. Roland Edwards and Co., Ltd., 317, High Holborn, London, W.C.1, the problem has been successfully solved without resorting to glass wool. By an ingenious arrangement of compartments of carefully adjusted volume, it has been found possible to keep the plates completely covered with acid in two alternative positions at right angles, so that an attaché case set fitted with one of these batteries could be worked equally well either in a horizontal or vertical plane. Further, the battery can be turned completely upside down, or, in fact, in any other position without the slightest trace of leakage. The provision of an unusually large compartment

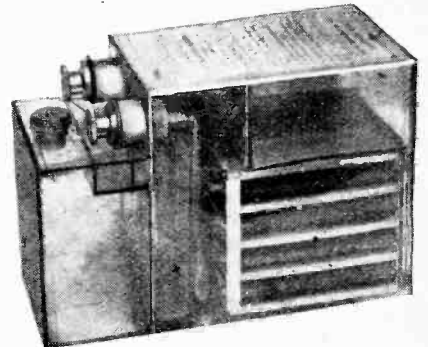

The acid completely covers the plates of the Edwards E.L.2 accumulator when placed horizontally as well as vertically.

on the top of the cell in addition to the normal acid trap is probably responsible for the perfect freedom of acid at the vent hole. The overall dimensions are 4in. x 2 3/4in. x 6in. high.

TRADE NOTE.**Mullard Depot in Newcastle.**

The Mullard Company announce the opening of a new depot at Newcastle-on-Tyne as from July 2nd. The address to which all future communications should be sent is as follows:—The Mullard Wireless Service Co., Ltd., 16, Clayton Street West, Newcastle-on-Tyne. Telephone: City 83. Telegrams: Mullard, Newcastle. Mr. W. J. Maxwell, recently technical representative for the Scottish and Northern Counties area, has been appointed the new depot manager. The depot at Handyside Arcade, Percy Street, Newcastle-on-Tyne, closed on June 30th.

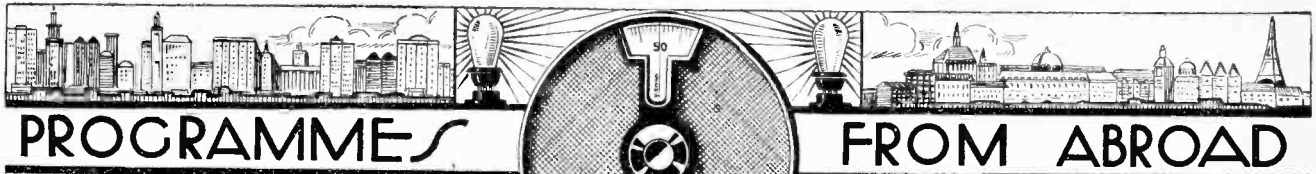

SATURDAY, JULY 21st.

All Times are reduced to British Summer Time and are p.m. except where otherwise stated.

BARCELONA (Radio-Barcelona), Call EAJ1 (344.8 metres); 1.5 kW.—6.0, Exchange Quotations, 6.10, Sextet Selections. 9.0, Exchange Quotations and News. 9.5, Orchestral Selections: March, Jollity (Ganglberger); American Dance, La Desposada (Cotó); Selection from Lysistrata (Lincke); Waltzes from The Waltz Dream (Oscar Straus); Consolation No. 3 (Liszt); Overture to La Sirène (Auber). 10.5, Programme relayed from Madrid, EAJ7.

BERGEN (370.4 metres); 1.5 kW.—11.15 a.m., Foreign Exchanges. 12.15, Weather Report and News. 8.0, Orchestral Concert: Turkish March from The Ruins of Athens (Beethoven); Ave Maria (Bach-Gounod); Fantasia (Delibes); Ritorno (Carosio); Valse Triste (Sibelius); Folk Songs; Selection from The Czardas, Princess (Kalman). 9.0, Miss Tonny Martens, Talk: Japan. 9.30, Piano-forte Recital by Mrs. Sandra Broucker. 10.0, Weather Report, News and Time Signal. 10.15, Concertina Concert. 10.45, Dance Music, relayed from the National Exhibition. 12.0 Midnight (approx.), Close Down.

BERLIN (Königswusterhausen) (1,250 metres); 40 kW.—4.0, Legal Talk. 4.30, Dr. Couvé, Talk: Personal Opinions on the Fundamentals of Psycho-Technology. 5.0, Relay of Concert from Hamburg. 6.0, Ing. Kumbusch, Talk: Safeguarding Against Accidents in the Iron Industry. 6.30, Max Vollmberg, Talk: Between Canada and Panama. 6.55, Dr. Hüne and Joh. Strauss, Talk: The Comic Element in Piano-forte Music. 7.20, Prof. Minde-Pouet, Talk: Goethe and Modern Creative Art. 7.50, Programme from Cologne. 8.30, Programme from Voxhaus.

BERLIN (Voxhaus) (484 metres); 4 kW.—6.0 a.m., Morning Gymnastics. 10.10 a.m., Market Prices. 10.15 a.m., Weather Report, News and Time Signal. 11.0 a.m., Programme of Gramophone Records. 11.30 a.m., Exchange Quotations. 3.0, Exchange Quotations. 3.10, Agricultural Prices and Time Signal. 3.30, Programme of Gramophone Records. 4.30, Medical Hygiene Talk by Dr. Paul Frank. 5.0, Heinz Stroh, Talk: Joachim Ringelnatz; Recitation from his Works by Ilse Davidsohn. 5.30, Concert from the Hotel Kaiserhof, followed by Programme Announcements. 7.0, Helmut Jaro Jarecki, Talk: The Seventieth Birthday of Lovis Corinth. 7.30, Dr. Max Apel, Talk: The Life of the German Philosophers of the Nineteenth Century, Rudolph Hermann Lotze. 8.0, Dr. Kurt Richter, Talk: American Travels. 8.30, Variety Programme, followed by Weather Report, News, Time Signal and Sports Notes. 10.30, Dance Music. 12.30 a.m. (Sunday), Close Down.

BERN (411 metres); 1.5 kW.—8.0, Time Signal and Weather Report. 8.2 (approx.), Orchestral Music. 9.30, Bee-keeping Talk, relayed from Basle (1,000 metres). 9.0, Yodel Songs and Zither Selections. 9.45, News and Weather Report. 10.0, Selections by the Bern Orchestra. 10.35, Dance Music. 12.0 Midnight (approx.), Close Down.

BRESLAU (322.6 metres); 4 kW.—6.15, Esperanto Lesson. 6.30, Talk: Woman in Modern Life, relayed from Gleiwitz (250 metres). 7.25, Art and Literature Review. 7.50, Advanced English Lesson. 8.30, Concert: Orchestral Selections; March, Über den Ozean (Vos); Humorous Selections; Song and Boston, Das Lied der Liebe (Berlin); Tango, Sirocco (Stolz); Fox-Trot (Kollo); Tango, Casanova (Stranck); Bassoon Selection from Im tiefen Keller (Kröpsch); Humorous Selections; Serenade (Arnold); Song (Egen); Three Bostons (Kalman and Ralton); Intermezzo (Schreiner); Comic Polka (Fueki); Humorous Selections; Spieldöschen (Portnoff); Tango (Alfonso). 10.0, News and Announcements. 10.30, Programme relayed from Gleiwitz, Concert and Dance Music from the Hindenburg Café. 12.0 Midnight (approx.), Close Down.

BRÜNN (441.2 metres); 3 kW.—6.0, Time Signal and German Transmission. 6.25, Programme of Talks. 7.0, Variety Item Programme. 8.25, Comedy (Sylak). 9.0, Exhibition Programme. 10.0, Programme from Prague. 10.20, Exhibition Programme.

BRSSELS (508.5 metres); 1.5 kW.—5.0, Dance Music from the St. Sauveur Palais de Danse. 6.0, Talk: Belgium. 6.30, Orchestral Concert: Aphrodite

HAMBURG, Call HA (in Morse) (394.7 metres); 4 kW.—5.0, Mozart Concert. 6.0, Request Orchestral Concert. 7.0, Dora Mohlehnke, Talk: Old Hamburg. 7.25, Dr. Dirksen, Talk: Lovis Corinth—on the Occasion of his 70th Birthday. 8.0, Concert of German Marches, relayed from Hanover (297 metres): First Battalion Army March No. 7; Army March No. 9, The Duke of Brunswick; Army March No. 240, Prussia's Glory (Piefke); The Old Berne March (1852); Frisch voran (Keckling); Des grossen Kurfürsten Reitermarch (Moltke); Kavallerie-Präsentier Marsch (Fischer); Badonville March (Fürst); Wedding March from "The Pied Piper of Hamelin" (Nessler); Hoch und Deutschmeister-Marsch (Ertl); Quick March on themes by Johann Strauss; Military March 126; Ein Manneswort (Pollak). 9.15, Programme relayed from Bremen (272.7 metres)—Cabaret Concert, followed by Weather Report, News, Sport Notes and Concert from the Winterhuder Café.

HILVERSUM (1,071 metres); 5 kW.—11.40 a.m., News. 12.10, Concert of Trio Music. 1.40, Programme relayed from the Tuschinski Theatre, Amsterdam. 3.10, Dance Music from the Kurhaus, Scheveningen. 5.40, Time, followed by Concert: Overture to Sunshine and Moonlight (Swart); Waltz, The Wedding of the Winds (Hall); Serenade à Lisette (Caludi); Love (Massenet); Ritter's Abschied (Kinkel); Selection from The Tales of Hoffmann (Offenbach); Serenade from "Les Millions d'Arlequin" (Drigo); Die Vesper (Beethoven); Kerstlied (Diamant); Wiener Zugvögel (Translater); Selection from The Circus Princess (Kalman). 7.25, News. 7.40, Programme arranged by the Workers' Radio Society. 11.10 (approx.), Close Down.

HUIZEN (340.9 metres); 4 kW.—Transmits from 5.40 p.m. on 1,870 metres. 12.10, Concert of Trio Music. 5.10, Gramophone Selections. 7.25, Song Selections with Lute Accompaniment. 7.55, Concert by Male Voice Choir and Humorous Selections.

JUAN-LES-PINS (Radio L.L.) (244.5 metres); 1.5 kW.—1.0, Orchestral Concert. 9.0, News and Weather. 9.5, Concert: Programme of Dance Music of 1910. 10.0, Dance Music. 10.30 (approx.), Close Down.

KALUNDBORG (1,153 metres); 7 kW.—Programme also for Copenhagen (337 metres)—7.30 a.m., Morning Gymnastics. 11.0 a.m., Weather Report (Kalundborg only). 3.0, Concert: Moment Musical (Schubert); Allegretto from Symphony No. 8 (Beethoven); Minuet from Symphony in E Flat Major (Mozart); Allegro from Piano-forte Trio in E Flat Major, Op. 1, No. 1 (Beethoven); Wiegeliend (Brahms); Hungarian Dance in G Minor, No. 6 (Brahms); Recitations by Emma Wiehe; Suite, Le Tombeau de Couperin (Ravel); Selections from Samson and Delilah (Saint-Saëns); Vision (Gounod); Meditation (Gounod); Marche Militaire in D Major (Schubert). 6.29, Talk, by Poul Pedersen. 6.50, Weather Report (Kalundborg only). 7.0, News and Exchange Quotations. 7.15, Time Signal. 7.20, Programme Announcements. 7.30, F. Meyer Frederiksen, Talk: Christian Erlund. 8.0, Chimes from the Town Hall. 8.2, Radio Summer Ball, followed by News. 9.15, Modern Dance Music. 10.45, Dance Music by the Arena Establishment Orchestra. 12 Midnight, Chimes from the Town Hall, Copenhagen. 12.15 a.m. (Sunday), Modern Dance Music. 1.0 a.m. (approx.), Close Down.

KAUNAS (2,000 metres); 7 kW.—12.0 Noon, Carillon. 7.0, Gramophone Selections. 9.15, Popular Concert and Dance Music.

LAHTI (1,522.8 metres); 35 kW.—5.57, Time Signal and Weather Report. 6.15, Concert: Overture to Flotte Bursche (Suppé); Waltz, Weaner Mäd'l (Ziehrer); Chanson et Conte (Konizak); Xylophone Solos; Vale (Waldteufel); Klar zum Gefecht (Blankenburg); Selection from Tannhäuser (Wagner); Cradle Song (Strauss); Achtung! New York! (Bochert); Musical Selections and Songs; Selection from Eva (Lehár); Selection from Countess Mariza (Kalman). 8.45, News in Finnish and Swedish, followed by Concert relayed from a Restaurant. 10.0 (approx.), Close Down.

(Jongen), Heeft het roosje milde geuren (Benoit); Milenka (Blockx); Song (Vreuls); Flemish Sketches (Brusselmanns); Rumanian Song (Jongen); Minuet (Gilson); Melody (de Boeck); Two Piano-forte Selections (Frankk); Melody (Blockx); Breton Scenes (Sarly). 7.30, "Radio-Chronique." 8.15, Gramophone Selections. 8.30, Literary Programme. 9.0, Concert, relayed from the Ostend Kursaal; News. 10.30 (approx.), Close Down.

BUDAPEST (555.6 metres); 35 kW.—5.50, Concert of Operetta Airs. 7.0, Two One Act Plays (Szini and Klara Zemleni). 8.0, Concert by the Orchestra of the Royal Hungarian Opera House: Programme from the Works of Grieg, Autumn Overture, Lyric Suite, Norwegian Dances, Suite from Peer Gynt, Suite No. 2 from Peer Gynt, Suite (Sigurd Jorsalfar); in the Interval, Time Signal and News. 11.0, Programme of Tzigane Music. 12.0 Midnight (approx.), Close Down.

COLOGNE (283 metres); 4 kW.—10.40 a.m., Market Prices. 1.5, Concert: March, Ordre de bataille (Lehnhardt); Tragische Overture (Brahms); Souvenirs of Beethoven (Urbach); Pavane pour une Infante défunte (Ravel); Jougou and Waldnixon (Ertl); Bass Solos (R. Strauss), (a) Nichts, (b) Die Zeitlose, (c) Ach weh, mir unglückhaften Mann; Selections from The Mastersingers (Wagner); Waltz, Estudiantina (Waldteufel). 2.30, See Langenberg. 3.40, See Langenberg. 4.0, Reading. 4.30, See Königswusterhausen. 5.0, Sports Talk for Women. 5.30 to 6.55, See Langenberg. 7.20, Talk for Workers. 7.45, See Langenberg. 8.10, Talk, The German Athletic Festival. 8.15, Popular Programme—"On the Telephone" (from the French by Wilhelm Mejo), followed by News, Sports Notes, Orchestral Selections and Dance Music. 1.0 a.m. (approx.) (Sunday), Close Down.

CRACOW (566 metres); 1.5 kW.—6.0, Programme for Children. 7.0, Miscellaneous Items. 7.30, Dr. Regula, Talk: Foreign Affairs of the past week. 7.55, Market Prices and News. 8.15, Programme from Warsaw. 10.30, Restaurant Concert. 11.30 (approx.), Close Down.

DUBLIN, Call 2RN (319.1 metres); 1.5 kW.—1.30, Weather Report and Concert of Gramophone Selections. 7.20, News. 7.30, Talk, by Frank Fay. 7.45, Irish Talk, by Seamus O'Duirinne. 8.0, S. MacAonghusa (Uileann Pipes). 8.15, Gaelic Selections by the Station Orchestra. 8.30, Baritone Solos, by Leslie Bennett. 8.40, Anhrain Gaedhíge, by M. Ni Annagan. 8.50, Baritone Solos by Leslie Bennett. 9.0, "Aerial Revellers" by H. O'Donovan and Company. 10.0, Banjo Solos by Jack MacGarvey. 10.15, Selections by the Station Orchestra. 10.30, News, Weather Report and Close Down.

FRANKFURT (428.6 metres); 4 kW.—6.30, Answers to Correspondents. 7.0, Talk, The Swiss Poet Conrad Ferdinand Meyer. 7.30, Concert by the Holle'schen Madrigal Society of Stuttgart: Two Songs (Lemacher); Selections (Brückner), (a) Motet No. 1, (b) Ave Maria, (c) Motet No. 4; Choral Selections (Hass); Two Songs (Wolf); Three Songs, Op. 138 (Max Reger). 8.30, Variety Concert and Programme relayed from Voxhaus.

Saturday, July 21st.

All Times are reduced to British
Summer Time and are p.m. except
where otherwise stated.

Programmes from Abroad.—

LANGENBERG (468.8 metres) ; 20 kW.—Programme also for Aix-la-Chapelle (100 metres), Cologne (283 metres) and Münster (250 metres).—10.40 a.m., See Cologne. 1.5, See Cologne. 2.30, Household Hints. 3.40, Talk: Wireless Technique, from Elberfeld. 4.0, See Cologne. 4.30, See Königswusterhausen. 5.0, See Cologne. 5.30, Elementary English Lesson from Münster. 6.0, Instrumental Concert from Düsseldorf: Trio for Viola, Flute and Harp (Debussy); String Quartet in D Major, Op. 11 (Tchaikovsky). 7.20, See Cologne. 7.45, Talk: Old Miner's Tales, from Münster. 8.10 to 1.0 a.m. (Sunday), See Cologne.

LEIPZIG (365.8 metres) ; 4 kW.—7.0, Talk: Plant Life under the Sea and Rivers. 7.30, Talk: Wandering in the South Hartz Mountains. 8.0, Weather Report and Time Signal. 8.15, Concert from Rudolf Delinger's Operettas: March from Don Cesar, Songs from Jadviga, Song from Don Cesar, Song from Die Wunderblume, Waltz from Saint Eyr, Songs from Don Cesar, Siciliana from Die Chansonette, Songs from Lorraine, Song and Duet from Comtesse Rita, Song from Saint Eyr, March from Capitan Fracassa. 9.15, Cabaret Programme, News in the Interval. 12.0 Midnight (approx.), Close Down.

LILLE, Call PTT (264 metres) ; 0.5 kW.—12.30, Concert: Overture to La Fille de Madame Angot (Lecocq); Summer Days (Coates); Violin Solo, Réverie (Vieuxtemps); Gigue (Wormser); Rondo (Nerini); The Nuremberg Doll (Adam). 1.35, Agricultural Report and Harbour Notes. 3.0, Hygiene Talk by Mme. de Surgère, followed by "Le Baiser," Play (de Banville). 7.0, Market Prices. 7.10, Concert, arranged by the "Journal l'Echo du Nord." 8.20, Wireless Talk, by Toto le Galenueux. 8.30, Concert, arranged by the Wireless Association of North France; News.

MADRID (Union Radio), Call EAJ7 (375 metres) ; 5 kW.—7.0, Organ Recital: Prelude No. 8 (Bach); Impromptu in A Flat Major (Schubert); Moment Musical (Schubert); Minuet in E Major (Bach); En la Montaña (Almagro); Interlude, by Luis Medina. 8.0, Dance Music. 9.45, Market Prices Report. 10.0, Chimes, followed by Symphony Concert: Overture (Beethoven); Pavane (Faure); Selections from Le Coq d'Or (Rimsky-Korsakoff); Symphony No. 1 (Schumann); Castilla Suite (Cantos); Overture to The Mastersingers (Wagner). 11.50 (approx.), News. 12.0 Midnight, Dance Music. 12.30 a.m. (Sunday), Close Down.

MILAN, Call LMI (526.3 metres) ; 7 kW.—8.35, Time Signal and Talk: History and Ethics of Music. 8.45, News and Variety Concert: Symphony from Nabucco (Verdi); Selection from Così Fan Tutte (Mozart); Soprano Solo, Porgi Amor (Giovanni); Reading; Trio (Beethoven); Gigue (Limental); Sonata in D Major (Paganini); Carillon (Ranzato); Variations on Moses' Prayer (Rossini); Air with Violin Obligato (Mozart); Soprano Air from Domeneo (Mozart). 10.55, News, followed by Dance Music from the Cova Restaurant. 11.30 (approx.), Close Down.

MOTALA (1,380 metres) ; 30 kW.—Programme also for Stockholm (154.5 metres), Boden (1,190 metres), Göteborg (416.5 metres), Malmö (260.9 metres), Östersund (720 metres), Sundsvall (545.6 metres).—5.30, Programme for Children. 6.15, Cabaret Show Concert. 7.30, Concert from the Tradsgårdsföreningen, Göteborg. 8.30, "The Bear," Play (Tchekov). 9.0, Talk: Professions and Professionals. 9.15, News and Weather Report. 9.45, Talk on Topical Events. 10.0, Dance Music. 12.0 Midnight (approx.), Close Down.

NAPLES, Call INA (333.3 metres) ; 1.5 kW.—2.0, Exchange Quotations and News. 4.45, Weather Report and News. 4.50, Variety Selections. 4.58, Exchange Quotations. 5.0, Concert of Variety Music: Orchestral Selections, (a) Minuet (Romano), (b) Notte d'Incanto (Cerrì); Soprano Solo, La Danse des Libellules (Lelhr); Orchestral Selections, (a) Castellammare (Brunetti), (b) Danse Burlesque (Criscuolo); Soprano Solo from La Bayadère (Kalmán); Orchestral Selections, (a) Fantasia on La Donna Perduta (Pietri), (b) Tango, Natakima (Marchetti); Soprano Solo, Romance from Addio Giovinetta (Pietri); Orchestral Selection, One-Step, Hello Zanzibar. 5.30, Time Signal. 5.35, Talk by R. Lotto. 8.20, Wireless Notes. 8.30, Government Report. 8.40, Time Signal. 8.48, Harbour Notes. 8.50, Selections of Light Music for Orchestra: La Regina del Fox-Trot (Sacconi); Gondola d'Amor (Mercuri); Visione Veneziana (Broggi); Il Ragno Azzurro (Randegger). 9.30, Programme relayed from the Eldorado Theatre; in the Interval, Dance Music. 10.55, Calendar and Announcements. 11.0 (approx.), Close Down.

OSLO (461.5 metres) ; 1.5 kW.—Programme relayed by Hamar (555.6 metres), Fredrikstad (434.8 metres),

Notodden (411 metres), Porsgrund (500 metres) and Rjukan (148 metres).—7.45, Weather Report and News, followed by Topical Talk. 8.0, Time Signal, followed by Gramophone Selections. 8.30, Talk: Trout-Fishing, followed by Concert. 9.30, Weather Report, News and Topical Events Talk. 10.0, Dance Music. 12.0 Midnight (approx.), Close Down.

PARIS (Ecole Supérieure), Call FPTT (458 metres) ; 0.5 kW.—Programme relayed at intervals by the following stations: Bordeaux PTT (275 metres), Eiffel Tower (2,650 metres), Grenoble (416 metres), Lille PTT (264 metres), Limoges (285 metres), Lyon PTT (476 metres), Marseilles (303 metres), Rennes (280 metres) and Toulouse PTT (260 metres).—8.15, Sports Talk and Notes. 8.45, Talk on Legal Affairs. 9.0, Concert by the Association Générale des Auditeurs de T.S.F., followed by Dance Music from the Coliseum de Paris.

PARIS (Eiffel Tower), Call FL (2,650 metres) ; 5 kW.—8.45, Le Journal Parlé. 8.10, Weather Report. 8.30, Concert: Bucoliques (Dulaurens); Three Popular Russian Songs, (a) Song of the Volga Boatmen, (b) Le Bouleau, (c) Nuit d'automne; La mort de Tintagiles (Cools); Appassionato (Filippucci); Three Popular Russian Songs, (a) Le joyeux marchand, (b) Près du pont, (c) Simple Histoire; Feuilles d'album (Levadé). 9.30, Educational Programme. 10.0, Close Down.

PARIS (Petit Parisien) (340.9 metres) ; 0.5 kW.—8.45, Gramophone Selections, Talks, News and Announcements. 9.0, Concert: Overture to Stradella (Flotow); Selection from Le Cœur et la Main (Lecocq); Symphony Orchestra, (a) 2nd Movement from the First Symphony in B Major (Schumann), (b) Danse macabre (Saint-Saëns); Ballet from Hérodiade (Massenet); Selection from La Montagne (Filippucci); Finale from The Ballet Egyptian (Luigini). News in the Interval.

PARIS (Radio-Paris) Call CFR (1,750 metres) ; 6 kW.—12.30, "Columbia" Gramophone Concert: The First Symphony in C Major; The Toreador's Air from "Carmen" (Bizet); Spanish Dances for Cello (Granados); Is She my Girl Friend? The Debroy Somers Band; Waltz, The Song is Ended; Guitar Solo, Meadow Lark; The Singing Sophomores, Hello Aloha How Are You?; La visite à la Dame (Dalroze); Le Beau Bébé (Dalroze). News. 1.50, Exchange Quotations and Religious News. 3.45, Dance Music, News. 8.0, Agricultural Report. 8.15, Talk and News. 8.30, Variety Concert: Songs, (a) Chant de la pluie (Lancel), (b) Derrière les volets (Lardi), (c) Fernons nos rideaux (Delmet); English Melodies; Conte de la Linousine (Nigond); Melodies by Mlle. Guellier; The Jos Ghisley Symphonians, News.

PITTSBURGH, Call KDKA (63 and 27 metres) ; 25 kW.—11.0, Time Signal and Baseball Scores. 11.25, KDKA Theatrical Calendar and Cambria Fair News. 11.30, The Westinghouse Band from the William Penn Hotel. 11.55, Baseball Announcements. 12.0 Midnight, Time Signal and The Westinghouse Band continued. 12.15 a.m. (Sunday), Isaak Walton League: History and Theory of Fly-casting. 12.30 a.m., Home Radio Club. 12.45 a.m., American Literary Gems. 1.0 to 4.0 a.m., New York relay. 1.0 a.m., Ryker and Mack. 1.15 a.m., Julius Klein, Talk: A Week of the World's Business. 1.30 a.m., Goldman Band Concert. 4.0 a.m., Weather Report, Telechron Time and Baseball Announcements. 4.20 a.m. (approx.), Close Down.

POSEN (344.8 metres) ; 1.5 kW.—6.0, Programme from Cracow. 7.0, Programme of Talks. 8.5, Bulletin of Finance. 8.30, Programme from Warsaw. 10.0, Time Signal, Weather Report and News. 10.20, Miscellaneous Items. 10.40, Dance Music from the Carlton Restaurant. 12.0 Midnight, Experimental Concert. 2.0 a.m. (approx.) (Sunday), Close Down.

PRAGUE (348.9 metres) ; 5 kW.—6.0, German Transmission. 6.25, Talk for Workers. 7.0, Variety Item Programme. 8.30, Dramatic Selections. 9.0, Programme from Brünn. 10.0, Time Signal, News, and Orchestral Selections from the Stranota Café, Prague.

ROME, Call IRO (450 metres) ; 3 kW.—1.30, Opening Signal. 1.32, Trio Concert. 2.30, News. 4.50, Wire-

less Talk. 5.15, Agricultural Report. 5.29, Time Signal. 5.30, Vocal and Instrumental Concert: Trio Op. 9 for Pianoforte, Violin and Cello (Mendelssohn); Soprano Solos, (a) Abendtraum (Strauss), (b) Air from Falstaff (Verdi); Tenor Solos, (a) Quel Ruscelletto (Paradies); (b) Nel plenitium (Breschi); Trio Selection, Larghetto e Scherzo (Ferrari); Tenor Solos, (a) Two English Ballads, (b) Air from Manon (Massenet); Soprano Solos, (a) Air from Piccolo Marat (Mascagni), (b) Air from La Bohème (Leoncavallo). 8.10, Time Signal and Government Report. 8.30, Sports Notes, News and Weather Report. 8.47, Topical Talk. 8.59, Time Signal. 9.0, "La Falce," Oriental Eclogue (Catalani), followed by "Fedora," Opera (Giordano). In the Interval—Review of Art and Literature, and Talk. 11.5, News. 11.15, Close Down.

SCHENECTADY, Call 2XAD and 2XAF (21.96 and 31.4 metres) ; 30 kW.—11.25, Baseball Announcements. 11.30, Orchestral Selections. 12.25 a.m. (Sunday), Baseball Scores. 12.30 a.m., "Statter's Pennsylvanians" relayed from New York. 1.0 a.m., "Bonnie Ladies," Programme relayed from New York. 1.30 a.m., Selections by Philharmonic Orchestra. 3.20 a.m., Organ Recital by Robert Berentsen (Rochester). 4.0 a.m., Dance Music from the Hotel de Witt Clinton, Albany. 5.0 a.m. (approx.), Close Down.

STAMBOUL (1,200 metres) ; 5 kW.—4.30, Orchestral Concert. 5.30, Market Prices Report. 6.15, Concert of Turkish Music. 8.30, Orchestral Concert: Overture to Tannhäuser (Wagner); Selection from Tannhäuser (Wagner); Shepherd Song (Wagner); Song, March from The Twilight of the Gods (Wagner) 10.0, News and Close Down.

STUTTGART (379.7 metres) ; 4 kW.—6.0, Time Signal and Weather Report. 6.15, Talk: Catholic Poetry of the Present Day, relayed from Freiburg (377 metres). 6.45, Legal Talk. 7.15, Dr. Bröner, Talk: A Journey to the East. 7.50, Time Signal, Weather Report and Sports Notes. 8.15, Chamber Music: Quartet in C Major (Mozart); Quartet in A Minor Op. 29 (Schubert). 9.0, Cabaret Concert followed by News.

TOULOUSE (Radiophonie du Midi) (391 metres) ; 3 kW.—12.30, Orchestral Concert. 8.0, Time Signal, News and Exchange Quotations. 8.30, Recital of Spanish Airs. 9.0, Concert: Part I—Programme of Overtures; Les Saltimbanques (Ganne); Les Cloches de Corneville (Planquette); Les Dragons de Villars (Maillart); Manon (Massenet); The Magic Flute (Mozart); The Merry Wives of Windsor (Nicolaï); The Barber of Seville (Rossini); The Italian in Algiers (Rossini); Poet and Peasant (Suppé); Light Cavalry (Suppé); Part II—Military Music Programme; Altekamaraden (Teike); Frederick the Great (Grobe); Défilé des Gladiateurs (Blankenburg); Marche du Comte Albert (Komzak); La Vie Heureuse (Schrannell); Le Fidèle Compagnon (Schermerich); Chant d'Enfant (Ziehrer); Triumphant March of the Gladiators (Fucik); Dans la Czarda (Geza); Olympiade March (Bohlander). 10.15, North African News.

VIENNA (577 and 517.2 metres) ; 1.5 and 5 kW.—6.15, Vocal and Instrumental Concert: Der Schwan (Grieg); Air from The Pearl Fishers (Bizet); Cäcilie (Strauss); Violin Solos, (a) Polonaise in A Major (Wieniawsky), (b) Volga Song (Kreisler), (c) Caprice (Paganini-Kreisler); An Die Leier (Schubert); Oh, Star of Eve from Tannhäuser (Wagner); Liebesfeier (Weingartner); Selection from The Kreidekreisliedern (Wladigerov); Der Letzte Tanz (Mittler); Schlaf Ein, Mein Lied (Pamer); Ballad in G Minor (Chopin); Pastorale and Caprice (Scarlatti-Taussig); Paraphrase on a Mazurka (Liszt-Chopin). 7.45, "Die Landstreicher" Operetta (Ziehrer), followed by Dance Music.

VILNA (435 metres) ; 1.5 kW.—7.5, Gramophone Selections. 7.30, Talk: The Coming Season in the Cinema World. 7.55, News and Announcements. 8.15, Programme from Warsaw. 11.30 (approx.), Close Down.

WARSAW (1,111 metres) ; 10 kW.—7.0, Miscellaneous Items. 7.30, Talk: Discoveries. 7.55, Agricultural Report and News. 8.15, Orchestral and Soloist Concert: March, Wienerblut (Komzak); Waltz (Helmesberger); Spring Song (Sibelius); Selection from Eugen Onegin (Tchaikovsky); Overture to The Bartered Bride (Smetana); Song; Violin Solo; Selection from The Mastersingers (Wagner); Italian Caprice (Tchaikovsky); Overture to Verbum Nobile (Moniuszko); Recitations; Mazurka from The Haunted Castle (Moniuszko); News in French in the Interval. 10.0, Time Signal, Aviation Notes, Weather Report, News and Sports Notes. 10.30, Dance Music from the Oaza Restaurant. 11.30 (approx.), Close Down.

SUNDAY, JULY 22nd.

All Times are reduced to British
Summer Time and are p.m. except
where otherwise stated.

Programmes from Abroad.—

BARCELONA (Radio-Barcelona), Call EAJ1 (344.8 metres); 1.5 kW.—12.0 Noon, Chimes from the Barcelona Cathedral, Regional Weather Report and General Weather Forecast. 1.30, Concert by the Iberia Instrumental Trio. In the Intervals Gramophone Record Selections. 2.45 to 9.0, Interval. 9.0, Opening Signal followed by Sports Notes, Market Prices. 9.15, Selections by the Station Orchestra. In the Intervals Talks. 10.0, Chimes from the Barcelona Cathedral, followed by Vocal and Instrumental Concert. 11.0 (approx.), Close Down.

BERGEN (370.4 metres); 1.5 kW.—10.30 a.m., Church Service and Religious Address. 12.30, Weather Forecast and News Bulletin. 8.0 (approx.), Orchestral Concert followed by Talk, Weather Forecast, News Bulletin, Time Signal and Dance Music. 12.0 Midnight, Close Down.

BERLIN (Königswusterhausen) (1,250 metres); 40 kW.—6.30 a.m., Early Morning Concert relayed from Voxhaus. 9.0 a.m., Sacred Recital relayed from Voxhaus followed by Cathedral Chimes. 11.30 a.m., Concert relayed from Voxhaus. 2.0, Children's Musical Programme relayed from Voxhaus. 3.0, Practical Talk for amateur photographers by Jens Lützen. 3.30, Agricultural Programme relayed from Voxhaus. 6.30, Programme of Talks, followed by Programme relayed from Voxhaus.

BERLIN (Voxhaus) (484 metres); 4 kW.—6.30 to 8.0 a.m., Orchestral Concert. 9.0 a.m., Vocal and Instrumental Concert followed by Chimes from the Berlin Cathedral. 11.30 a.m. to 12.50, Orchestral Concert. 2.0, Funkheinzelmann's Entertainment for Children. 3.0, Lesson in Shorthand arranged by the Hans Bredow School. 3.30, Programme of Agricultural Talks, followed by Musical Selections. 7.0, Programme of Talks followed by Musical Programme. 10.30, Dance Music Programme. 12.30 a.m. (approx.), (Monday), Close Down.

BERN (411 metres); 1.5 kW.—10.30 a.m. (approx.), Divine Service, and Sermon. 1.0, Time Signal and Weather Forecast. 1.5, Orchestral Selections. 3.30, Concert of Orchestral Music. 5.35 to 8.0, Interval. 8.0, Time Signal and Weather Forecast followed by Pianoforte Recital by Willi Girsberger. The Works of Franz Liszt. 9.45, Sports Notes, News Bulletin, and Weather Report. 10.0, Orchestral Concert. 10.35, (approx.), Close Down.

BREMEN (272.7 metres); 0.7 kW.—6.30 a.m., Concert relayed from Voxhaus. 8.25 a.m., Time Signal, Weather Forecast, News Bulletin and Commerce Notes from Hamburg. 9.15 a.m., Morning Recital from Hamburg. 11.0 a.m., Talk relayed from Hamburg. 12.55, Nauen Time Signal. 1.0, Instrumental Concert. 2.0, Children's Programme relayed from Voxhaus, followed by Programme of Talks and Music. 8.0, Musical Programme followed by Weather Report, News Bulletin and Concert relayed from the Georgpalast. 11.0 (approx.), Close Down.

BRESLAU (322.6 metres); 4 kW.—8.45 a.m., Chimes relayed from Christ Church, Breslau. 11.0 a.m., Catholic Morning Recital. 12.0 Noon, Orchestral Concert. 2.0, Short Talk for Gardeners. 2.10, Agricultural Talk. 2.35, Chess Talk by Adolf Kramer. 3.0, Fairy Tales for Children. 3.30, English Reading by Douglas Yates from John M. Synge's "The Aran Islands." 4.30, Orchestral Concert, followed by Programme of Talks. 8.30 (approx.), Musical Programme. 10.0, Last News Bulletin. 10.30, Dance Music Programme relayed from Voxhaus. 12.0 Midnight (approx.), Close Down.

BRÜNN (441.2 metres); 3 kW.—9.30 a.m., Agricultural Report. 10.0 a.m., Musical Programme. 12.0 Noon, Orchestral Concert. 4.0, Popular Concert. 6.0, German Transmission. 7.0, Orchestral Concert. 10.20, Musical Selections. 11.0 (approx.), Close Down.

BRUSSELS (508.5 metres); 1.5 kW.—5.0, Relay of Dance Music from the Kursaal in Ostend. 6.0, Programme for Children. 6.30, Instrumental Concert. 7.30, Le Radio-Chronique, Journal Parlé of Radio-Belgique. 8.15, Instrumental Concert of Chamber Music—Mme. Grandage and MM. André and Voordecker. 10.15, (approx.), News Bulletin. 10.30 (approx.), Close Down.

BUDAPEST (555.6 metres); 35 kW.—9.0 a.m., News Bulletin and Beauty Hints. 10.0 a.m., Divine Service. 12.0 Noon, Chimes, Weather Forecast and Musical Programme. 3.30, Agricultural Talk, followed by Programme of Talks and Music. 6.30 (approx.), Talk and Sports Notes, followed by Popular Programme. Sports Notes in the Interval; Tzigane Music at Close of Programme. 12.0 Midnight (approx.), Close Down.

COLOGNE (283 metres); 4 kW.—Programme also for Aix-la-Chapelle (400 metres), Langenberg (468.8 metres) and Münster (250 metres).—9.0 a.m., Evangelical Morning Recital. 11.0 a.m. to 9.0, Programme of Talks and Music. 9.0, Open Air Programme, followed by News Bulletin, Sports Notes and Orchestral Selections. 12.0 Midnight (approx.), Close Down.

CORK, Call 6CK (400 metres); 1.5 kW.—8.30, Concert by the Station Quintet with Mezzo-Soprano, Tenor and Baritone Solos. 11.0, National Anthem. 11.5 (approx.), Close Down.

CRACOW (566 metres); 1.5 kW.—10.15 a.m., Divine Service, relayed from a Polish Cathedral. 12.0 Noon, Fanfare from the Church of Notre Dame in Cracow, followed by Time Signal and Weather Forecast. 4.0, Programme of Agricultural Talks, followed by Dr. St. Wasniewski's Weekly Agricultural Report. 5.0, Programme relayed from Warsaw. 6.30, Variety Programme, followed by Talks. 8.0, Fanfare from Notre Dame, followed by Sports Notes. 8.30, Instrumental and Vocal Concert of Polish Music; Recital of Songs by Paderewski and Moniuszko by Mr. Roman Wraga. 10.0, Programme relayed from Warsaw. 10.30, Relay of an Orchestral Concert from a Restaurant. 11.30 (approx.), Close Down.

DUBLIN, Call 2RN (319.1 metres); 1.5 kW.—8.30, Concert of Instrumental, Solo and Vocal Music, relayed from Cork; Mme. K. McCaffery (Mezzo-Soprano). 11.0, National Anthem, relayed from Cork, followed by Close Down.

FRANKFURT (428.6 metres); 4 kW.—8.0 a.m., Sacred Morning Recital. 11.0 a.m., Talk for Parents on the Upbringing of Children. 11.30 a.m. to 6.0, Programme of Talks and Music. 6.0, Programme of the Rhein-Main Association for Popular Education, Talk. 8.0 (approx.), Musical Programme, followed by Dance Music relayed from Berlin. 12.30 a.m. (approx.) (Monday), Close Down.

HAMBURG, Call HA (in Morse) (394.7 metres); 4 kW.—Programme relayed by Bremen (272.7 metres), Hanover (297 metres) and Kiel (254.2 metres).—6.30 a.m., Early Morning Concert, relayed from Voxhaus. 8.25 a.m., Time Signal, Weather Report, News Bulletin and Commerce Notes. 9.15 a.m., Morning Recital. 11.0 a.m. (for Hamburg only), Talk, A Stroll through the Hamburg Museums. 12.55, Nauen International Time Signal. 1.0 (for Hamburg and Kiel only), Sunday Concert. 2.0, Musical Programme for Children, relayed from Voxhaus. 3.0 to 7.40, Programme of Talks and Music. 7.40, Sports Notes and Weather Report. 8.0, Musical Programme, followed by Weather Report, News Bulletin and Concert from the Café Wallhof (for Hamburg and Kiel only). 11.0 (approx.), Close Down.

HANOVER (297 metres); 0.7 kW.—6.30 a.m., Concert, relayed from Voxhaus. 8.25 a.m., Time Signal, Weather Forecast, News Bulletin and Commerce Notes from Hamburg. 9.15 a.m., Morning Recital from Hamburg. 11.0 a.m., Talk from Hamburg. 12.55, Nauen Time Signal. 1.0, Gramophone Record Selections, followed by Programme of Talks and Music. 8.0, Musical Programme, followed by Weather Report, News Bulletin and Concert relayed from the Georgpalast. 11.0 (approx.), Close Down.

HILVERSUM (1,071 metres); 5 kW.—10.10 a.m., Programme organised by the Workers' Radio Society. 12.40, Lunctime Music by a Trio. 2.40, Orchestral and Soloist Concert, relayed from the Kurhaus in Scheveningen; The Residence Orchestra, conducted by Ignaz Neumark. 4.25, Concert by the Wireless Orchestra, conducted by Nico Treep: Soprano Solos by Sophie Haase Pieneman. 7.40, Weather Report, News Bulletin and Sports Notes. 7.55, Concert by the Residence Orchestra from the Kurhaus in Scheveningen, conducted by Professor Georg Schneevogt.

HUIZEN (340.9 metres); 4 kW.—Transmits from 5.40 p.m. on 1,870 metres. 8.10 a.m., Religious Address and Sacred Music. 9.30 a.m. (approx.), Divine Service from a Church. 12.10, Concert by the Winkels Trio. 1.40, Instrumental Concert, followed by Programme for Hospitals and Divine Service. 7.30 (approx.), Musical Programme. 10.25, Choral Epilogue. 10.45 (approx.), Close Down.

JUAN-LES-PINS (Radio L.L.) (244.5 metres); 1.6 kW.—1.0 to 2.0, Concert by the Izar Orchestra of the Juan-les-Pins Casino. Talk for Children by Radiolo. Selections from "The Valkyrie" (Wagner). 9.0, News Bulletin, Weather Forecast and Musical Selections. 10.0, Dance Music by the Casino Orchestra. 10.30, Close Down.

KALUNDBORG (1,153 metres); 7 kW.—Programme also for Copenhagen (337 metres). 10.0 a.m., Divine Service relayed from a Church. 11.30 a.m. (for Kalundborg only), Weather Forecast. 2.0, Divine Service relayed from a Church. 6.50 (for Kalundborg only), Weather Forecast. 7.0, News Bulletin. 7.15, Time Signal. 7.30, Talk. 8.0, Time Signal, Chimes from the Copenhagen Town Hall. 8.5, Concert of Opera and Operetta Music; Part I, Selections from Modern Operettas; Part II, Selections from Italian Opera. 11.0 (approx.), Dance Music Programme. In the interval at 12.0 Midnight, Chimes from the Copenhagen Town Hall. 12.30 a.m., (approx.) (Monday), Close Down.

KATOWITZ (422 metres); 10 kW.—10.15 a.m., Divine Service. 12.0 Noon, Time Signal and News Bulletin. 4.0, Programme of Talks and Music. 8.15, Relay from one of the Polish Stations. 10.0, Time Signal and News Bulletin. 10.30, Programme of Dance Music. 11.30 (approx.), Close Down.

KAUNAS (2,000 metres), 7 kW.—12.0 Noon, Chimes and Weather Report. 12.10, Concert of Sacred Music. 5.0, Radio Journal for Agricultural Workers. 6.0, Variety Items. 7.30, Health Talk by Dr. Jurgelionis. 8.0, Talk. 8.30, Loving of the Flag on the Kaunas War Museum. 8.40, Time Signal, Weather Report and Political Review. 9.0, Orchestral Concert directed by Herr Schubert. Including Selections from "La Muette de Portici" (Aubert). 10.30 (approx.), Close Down.

KIEL (254.2 metres); 0.7 kW.—6.30 a.m., Concert relayed from Berlin. 8.25 a.m., Time Signal, Weather Report, News Bulletin and Commerce Notes relayed from Hamburg. 9.15 a.m., Morning Recital from Hamburg. 10.55 a.m., Divine Service relayed from the University Church in Kiel. 12.55, Nauen Time Signal. 1.0, Concert relayed from Hamburg. 2.0, Children's Programme relayed from Voxhaus, followed by Programme of Talks and Music. 8.0, Musical Programme, followed by Weather Report, News Bulletin and Concert from the Café Wallhof in Hamburg. 11.0 (approx.), Close Down.

KÖNIGSBERG (329.7 metres); 4 kW.—Programme relayed by Danzig on 272.7 metres. 9.0 a.m., Religious Address with Sacred Songs and Organ Music. 11.0 a.m. (for Königsberg only), Weather Report. 11.15 a.m. (approx.), Orchestral Concert. 12.55, International Time Signal from Nauen, followed by Weather Report. 3.0 (approx.) to 8.0, Programme of Talks and Music. 8.0, Concert of Classical Operetta Selections (Artistes: Arthur Preuss and Ruth Norden-Brenke); Selections from "Die Sieben Schwaben" (Müllöcker), (a) Otmar's Recitative and Air, (b) O Tag der Freude, (c) Mein Prinzipal ist Alchymist—Duet by Hannele and Spätzle, (d) Was zu einer Jungfer geh'ort—Duet by Hannele and Spätzle, (e) Du sagst... followed by Weather Report, News Bulletin and Sports Notes, followed by Dance Music Programme. 12.0 Midnight (approx.), Close Down.

LAHTI (1522.8 metres); 35 kW.—Programme also for Helsingfors (375 metres).—8.0 a.m., Relay of a Divine Service in Finnish. 10.50 a.m., Instrumental Concert. 11.50 a.m., Weather Forecast and Time Signal, followed by Talks and Music. 6.10, Orchestral Concert. In the Interval: Recital of "Cello Music by Tauno Korhonen. 8.45, Last News Bulletin in Finnish and Swedish. 9.15, Concert relayed from a restaurant. 10.0 (approx.), Close Down.

LANGENBERG (468.8 metres); 20 kW.—Programme also for Aix-la-Chapelle (400 metres), Cologne (283 metres), Münster (250 metres).—9.0 to 10.0 a.m., Evangelical Morning Recital relayed from Cologne. 11.0 a.m. to 9.15, Programme of Talks and Music. 9.0, Concert with the Hollersch Madrigal Choir relayed from Cologne, followed by News Bulletin, Sports Notes and Orchestral Selections. 12.0 Midnight (approx.), Close Down.

LAUSANNE (680 metres); 1.5 kW.—8.30, Sports Notes. 8.40, Relay of Protestant Service.

LEIPZIG (365.8 metres); 4 kW.—8.30 a.m., Organ Recital, relayed from a Church. 9.0 a.m., Vocal and Instrumental Morning Recital. 11.0 a.m., Outside Relay of a Concert. 12.0 Noon, Programme of Talks and Music. 9.0, "Blüten aus Indien," Poems by Alois Essigmann, read by Josef Krahé, (a) Indiens ewige Jugend, (b) Abendrot. 10.0, Sports Notes. 10.30, Dance Music Programme, relayed from Voxhaus. 12.30 a.m. (approx.) (Monday), Close Down.

Sunday, July 22nd.

All Times are reduced to British
Summer Time and are p.m. except
where otherwise stated.

Programmes from Abroad.—

LILLE, Call PTT (264 metres); 0.5 kW.—12.30, Concert of Orchestral Music organised by the Association de Radiophonie du Nord de la France, under the Auspices of the Radio-Club de Lille. 1.35, Market Prices of Motor Oils. 9.0 (approx.), Musical Programme.

LYONS (Radio-Lyon) (291 metres); 1.5 kW.—11.0 a.m., Orchestral Concert. 11.30 a.m., Sacred Music. 7.30, "Le Journal Paris," Weather Report, News Bulletin and Topical Talks, followed by Sports Notes and Agricultural Talk. 8.15, Concert: Part I, French and Italian Music; Part II, Ancient and Modern Dances. 10.30 (approx.), Close Down.

MADRID (Union Radio), Call EAJ7 (375 metres); 3 kW.—2.0, Concert by the Artys Orchestra. 7.0, Children's Corner, Kiki and his Friends; Selections by Luis Medina and Music by the Artys Orchestra. 8.0 to 8.30, Dance Music Programme. 10.0, Chimes and Time Signal, followed by Instrumental Concert. 12.0 Midnight, Dance Music Programme. 12.30 a.m. (approx.) (Monday), Close Down.

MILAN, Call IMI (526.3 metres); 7 kW.—10.30 a.m., Concert of Vocal and Instrumental Religious Music. 12.30, Concert by the E.I.A.R. Quartet. 4.0 (approx.), Quintet and Vocal Concert. 5.30 (approx.), Dance Music Programme. 8.15 to 8.25, Interval. 8.25, Opening Signal, followed by Programme of Talks. 8.35, Time Signal, followed by Talk, on the Margins of History, by A. Blanche. 9.0, "I Quattro Rusteghi," Opera, by E. Wolf Ferrari; during the Intervals, Sports Notes and News Bulletin. 11.45 (approx.), Close Down.

MOTALA (1,380 metres); 30 kW.—Programme also for Stockholm (154.5 metres), Boden (1,190 metres), Göteborg (416.5 metres), Malmö (260.9 metres), Östersund (720 metres), Sundsvall (545.6 metres).—11.0 a.m., Divine Service and Sermon, relayed from a Church. 12.45, Weather Forecast. 12.55, Time Signal. 5.55, Relay of Chimes from the Stockholm Town Hall. 7.45, Programme of Talks and Military Music in Honour of the Swedish Olympic Team, followed by Musical Selections; in the Interval at 9.15, News Bulletin and Weather Report. 11.0 (approx.), Close Down.

MUNICH (535.7 metres); 4 kW.—Programme relayed by Augsburg (566 metres), Kaiserlautern (204.1 metres) and Nuremberg (241.9 metres).—11.0 a.m., Chimes relayed from the Munich Town Hall. 11.15 a.m., Weather Forecast. 12.0 Noon, Instrumental Concert. 1.0 (approx.), Weather Report, Programme Announcements. 3.0 to 6.0 (approx.), Programme of Talks and Music. 8.0, Pianoforte Recital by Professor Georg Schumann, of Berlin. 8.0, Musical Programme, followed by News Bulletin and Relay of Dance Music. 11.30 (approx.), Close Down.

NAPLES, Call INA (333.3 metres); 1.5 kW.—10.0 a.m., Concert of Sacred Music. 4.45, Programme for Children. 5.0, Vocal and Instrumental Concert. 5.30, Time Signal. 8.20, Programme of Talks. 8.40, Time Signal. 8.45, Report of the Naples Harbour Authorities. 8.50, Concert of Opera Selections; Mezzo-Soprano Solos by Ada Testa, Tenor Solos by Renato Oriano, Soprano Solos by Hina Hisor, with Orchestral Accompaniment. 10.55, Calendar and Programme Announcements. 11.0 (approx.), Close Down.

OSLO (461.5 metres); 1.5 kW.—Programme relayed by Fredrikstad (434.8 metres), Hamar (555.6 metres), Notodden (411 metres), Forsgrund (500 metres) and Bjakan (418 metres).—10.20 a.m. (approx.), Chimes, followed by Divine Service. 7.45, Weather Forecast and News Bulletin. 8.0, Time Signal and Musical Programme. 9.30 (approx.), Weather Forecast, News Bulletin and Topical Talk. 10.30 (approx.), Dance Music, relayed from the Hotel Bristol, Oslo. 12.0 Midnight (approx.), Close Down.

PARIS (Ecole Supérieure), Call FPTT (458 metres); 0.5 kW.—Programme relayed at intervals by the following stations: Bordeaux PTT (275 metres), Eiffel Tower (2,650 metres), Grenoble (411 metres), Lille PTT (264 metres), Limoges (285 metres), Lyons PTT (478 metres), Marseilles (303 metres), Rennes (280 metres) and Toulouse PTT (260 metres).—8.0 a.m., News Bulletin and Time Signal. 10.25 a.m., International Time Signal and Weather Forecast. 1.30, Orchestral Concert, arranged by the Association Générale des Auditeurs de T.S.F.: Selection from La Belle au Bois Dormant (Tchaikovsky). 6.0, Le Radio-Journal de France. 8.30, Sports Results. 9.0, Instrumental Concert, followed by Dance Music Programme, relayed from the Coliseum de Paris. 12.0 Midnight (approx.), Close Down.

PARIS (Eiffel Tower), Call FL (2,650 metres); 5 kW.—8.56 a.m., Time Signal on 32.5 metres. 10.26 a.m., Time Signal on 2,650 metres. 6.45, Le Journal Parlé par T.S.F. Talks on Health, Police Anecdotes, Race Notes, etc., by Dr. Pierre Vachet, Detective Ashelbé, and other regular contributors. 8.10, Weather Forecast. 8.30, Concert by Mario Cazes and his Orchestra. 8.56, Time Signal on 32.5 metres. 11.26, Time Signal on 2,650 metres.

PARIS (Radio L.L.) (370 and 60 metres); 1 kW.—3.0, Orchestral Programme of Dance Music. 9.0, Gala Concert of Popular Russian and Tzigane Songs organised by La Compagnie de Radiodiffusion and conducted by M. le Général de Gorlenko. Chansons Tziganes by M. Apollon Lidine (Baritone) and Mme. Lydie Larina (Mezzo-Soprano).

PARIS (Petit Parisien) (340.9 metres); 0.5 kW.—8.45, Selections of Gramophone Music, followed by Talk and Press Review. 9.0, Orchestral Selections. 9.25, News Bulletin. 9.30, Half an Hour of Symphony Music conducted by Monsieur Estyle. 10.0, News Bulletin, followed by Orchestral Concert: Selections from the Ballet Music of "Véronique" (Massenet). 11.0 (approx.), Close Down.

PARIS (Radio-Paris), Call CFR (1,750 metres); 6 kW.—8.0 a.m., News Bulletin followed by Press Review. 12.0 Noon, Religious Talk followed by Concert of Sacred Music by a Choir, organised by "La Vie Catholique," News Bulletin. 12.45, Concert by the Albert Locatelli Orchestra. 4.30, Programme of Dance Music with News Bulletin in the Interval. 7.45, Programme for Children organised by Le Théâtre du Petit Monde. 8.15 (approx.), Agricultural Report followed by News Bulletin. 8.30, Concert with News Bulletin in the interval.

PITTSBURGH, Call KDKA (62 and 27 metres); 25 kW.—3.45, Time Signal. 4.0, Church Service. 7.0, Romy's Stroll Programme, relayed from WJZ, New York. 9.0, Time Signal followed by Dr. Sockman's Question Hour from WJZ. 10.0, Twilight Réveries from WJZ. 11.0, Telechron Time Signal. 11.25, Baseball Scores. 11.30, Orchestral Concert by the KDKA Ensemble, relayed from the Palm Room of the William Penn Hotel. Time Signal at 12.0 Midnight (in the interval). 1.0 a.m. (Monday), High Spots of Melody relayed from WJZ. 1.45 a.m., Programme by the Whittall Anglo-Persians from WJZ New York. Longtime. 3.15 a.m., Baseball Scores, followed by Telechron Time Signal. 3.30 a.m. (approx.), Close Down.

POSEN (344.8 metres); 1.5 kW.—10.15 a.m., Divine Service relayed from a Polish Cathedral. 12.0 Noon, Agricultural Talk. 12.50, Bulletin of the Polish League of Youth. 5.0, Symphony Concert relayed from Warsaw. 6.30, Programme of Talks. 8.15, Military Music with interludes by Mlle. Irene Felicka (Soprano) and M. Adam Raczkowski (Tenor). 10.0, Time Signal, News Bulletin, Weather Report and Sports Notes. 10.20 (approx.), Variety Items, followed by Dance Music Programme. 11.30 (approx.), Close Down.

PRAGUE (348.9 metres); 5 kW.—9.0 a.m. (approx.), Agricultural Report and Instrumental Music. 12.0 Noon, Orchestral Concert. 1.5, Commerce Notes, followed by Announcements and Musical Programme. 5.30, Programme for Workers. 6.0, German Transmission. 7.0 (approx.), Musical Items. 10.0, Time Signal and News Bulletin, followed by Variety Programme from Brunn. 11.0 (approx.), Close Down.

ROME, Call IRO (450 metres); 3 kW.—10.15 a.m., Opening Signal. 10.17 a.m., Concert of Vocal and Instrumental Sacred Music. 11.0 a.m. to 1.15 (approx.), Interval. 1.15 (approx.), Concert by the Station Trio. 5.0, Opening Signal. 5.2, Concert from the Studio. 6.0 to 6.30, Dance Music Programme relayed from the Casinetta, Rome. 8.20, Opening Signal. 8.22, Programme of Talks. 8.30, Sports Notes and News Bulletin. 9.0, Instrumental Concert, including Bach's Concerto in E Major played by Giulio Bignami (Violinist), (a) Allegro, (b) Adagio, (c) Allegro assai. 11.5, Last News Bulletin. 11.15 (approx.), Close Down.

SCHENECTADY, Call 2XAD and 2XAF (21.96 and 31.4 metres); 30 kW.—4.0, Divine Service relayed

from the First Presbyterian Church in Schenectady, with a Sermon by the Rev. Robert W. Anthony, Pastor. 10.30, Concert by the Ballad Singers relayed from New York. 11.0, The Stetson Parade—American Legion Band, Boston, Mass. 12.0 Midnight, Recital by Hans Barth (Pianist) relayed from New York. 12.25 a.m. (Monday), Baseball Scores relayed from New York. 12.30 a.m., Capitol Theatre Programme relayed from New York. 2.0 a.m., Talk on the Government of the United States by the Editor of The "United States Daily," relayed from Washington D.C. 2.15 a.m., Atwater Kent Programme from New York. 2.45 a.m., Correct Time. 2.47, Biblical Drama. 3.15 a.m., Experimental Transmission of Television Signals on 379.5 metres. 3.30 a.m. (approx.), Close Down.

STAMBOUL (1,200 metres); 5 kW.—4.30, Orchestral Selections. 5.30, Market Prices of Cereals. 6.15, Turkish Music. 8.30 (approx.), Weather Forecast. 8.40, Instrumental Concert. 10.0, News Bulletin by the Agence Anatolie. 10.30 (approx.), Close Down.

STETTIN (236 metres); 0.75 kW.—6.30 to 9.0 a.m., Instrumental and Vocal Music, relayed from Voxhaus. 11.30 a.m. to 12.0 Midnight, Programme of Talks, Concerts and Dance Music, relayed at intervals from Voxhaus.

STUTTGART (379.7 metres); 4 kW.—11.15 a.m. (approx.), Morning Recital, followed by Open-air Concert, relayed from the Castle Square in Stuttgart, and Gramophone Record Selections. 2.0, Musical Programme for Children, relayed from Voxhaus, followed by Talks and Concert. 6.0, Time Signal and Sports Notes, followed by Dramatic and Musical Programme; News Bulletin.

TOULOUSE (Radiophonie du Midi) (391 metres); 3 kW.—12.30, Instrumental Concert. 1.0, Chimes. 1.45, News Bulletins by the Papers, "Le Télégramme," "L'Express" and "Le Midi Socialiste." 8.0, News Bulletins by "La Dépêche" and "Le Petit Parisien." 8.30, Instrumental Concert. 9.0, Concert, arranged by the Association des Commerçants Radio-Électriciens, Toulouse: Selections from Pelléas et Mélisande (Debussy), (a) Interlude from Act I, (b) C'est au Bord de la Fontaine, (c) Interlude between Scenes 2 and 3 of Act II, (d) Vous ne rêvez pas, (e) Ah! ah! tout va bien, (f) Interlude between Scenes 2 and 3 of Act III, (g) Il fait beau cette nuit, (h) Je le tiens dans les mains, (i) Ah! je respire enfin, (j) Interlude from the Fourth Act, (k) Maintenant que le père (l) Une grande innocence, (m) Nous sommes venus (n) Quel est ce bruit? 10.15, North African News. 10.30 (approx.), Close Down.

VIENNA (577 and 517.2 metres); 1.5 and 5 kW.—Programme relayed by Innsbruck (291.1 metres), Klagenfurt (272.7 metres) and Linz (251.2 metres). 11.0 a.m., Concert by the Vienna Symphony Orchestra. 4.0, Instrumental Concert, followed by Programme of Talks and Music. 8.5, "Der Grosse Name," Comedy in Three Acts by Victor Léon and Leo Feld, Music by Robert Stolz.

VILNA (435 metres); 1.5 kW.—10.15 a.m., Divine Service, relayed from a Church. 12.0 Noon, Programme relayed from Warsaw. 4.0, Programme relayed from Warsaw, followed by Talks, Concert and Dance Music. 11.30 (approx.), Close Down.

WARSAW (1,111 metres); 10 kW.—10.15 a.m., Divine Service, relayed from a Polish Cathedral. 12.0 Noon, Time Signal, Fanfare from the Church of Notre Dame in Cracow, Aviation Report and Weather Forecast. 12.10 to 3.55, Interval. 3.55, Weather Forecast. 4.0, Three Agricultural Talks. 5.0, Concert by the Philharmonie de Varsovic. 6.30, Variety Selections. 7.50, Talk by Professor L. Kulczycki: The History of the Revolutionary Movements in Russia. 7.45, Ethnographical Talk by Professor St. Pomiatowski. 8.15, Popular Concert by the Philharmonie de Varsovic: Soprano Solos by S. Pinińska. 10.0, Time Signal, Aviation Report and Weather Forecast. 10.55, News Bulletin, Police Information and Sports Notes. 10.30, Dance Music relayed from the Oaza Restaurant, Orchestra directed by W. Roszkowski and I. Karbowski. 11.30 (approx.), Close Down.

ZAGREB (310 metres); 0.35 kW.—8.30, Wireless Propaganda, followed by Musical Programme and News Bulletin.

ZURICH (588 metres); 1 kW.—11.15 a.m., Concert of Orchestral Music by the Station Orchestra. 12.29, Weather Forecast. 12.30, Concert by the Station Quintet. 4.0, Orchestral Concert. 7.30, Protestant Address. 8.0, Request Concert by the Station Orchestra; in the Interval, Recital of Songs and Arias by Hely Menotti (Contralto). 10.0, Weather Forecast, News Bulletin. 10.15 (approx.), Close Down.

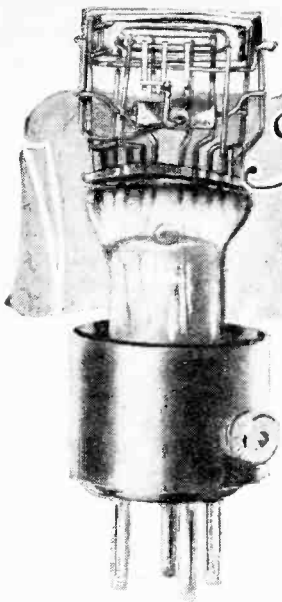

The OUTPUT STAGE and the PENTODE



A Comparison of the Quality of
Reproduction with Various Types
of Loud Speaker.

PART II.

(Continued from page 33 of previous issue.)

By N. W. McLACHLAN, D.Sc., M.I.E.E.

THE next point for discussion is the effect of the high internal resistance. So far as coil-drive loud speakers are concerned, it is ideal provided a high resistance coil or a well-designed transformer of high primary inductance and small leakage inductance is used. The object to be attained is uniform current at all frequencies—this fashionable object may change one of these days! Since the coil impedance is relatively negligible over the working band of audio frequencies, the current is substantially constant. To point a comparison between triode and pentode Fig. 8 has been added. The power triode of the order of 2,700 ohms resistance fails at the higher and at the lower frequencies (owing to its low internal resistance).

So far as reed-drive loud speakers of 2,000 ohms nominal resistance are concerned, it is doubtful whether the pentode will be found an agreeable companion. In present-day reed-drives using low resistance triodes, the current gradually decreases as the frequency increases, owing to the increased resistance and reactance of the winding. The decrease in current partially offsets the increase in response of the reed as its resonance frequency is approached. A valve of high internal resistance will clearly tend to make the current variation from low to high frequency much less than that with a valve of low internal resistance. Thus with the pentode the low and the middle frequencies will be reduced relative to the higher frequencies, unless, of

course, the loud speaker is specifically designed to fit the valve.

To illustrate this point concretely, some actual measurements on a reed-drive type of loud speaker have been given in Figs. 9 and 10. From Fig. 9 it will be seen that the effective resistance increases more rapidly than the frequency. This is due to the combined influence of hysteresis and eddy currents in the iron. The inductance falls with rise in frequency again owing to the eddy currents. Thus the top end of the curve of Fig. 10 droops slightly.

The impedance of the loud speaker at any frequency is the vector sum of the resistance and reactance as shown in Fig. 11. To get the total circuit impedance of the power valve the internal valve resistance is added as shown in Fig. 12. Two cases have been cited (a) for a power triode, (b) for a pentode. Clearly the pentode increases the circuit impedance to a much greater extent than the triode. Thus as the frequency rises the current with the triode decreases more rapidly than with the pentode, owing to the

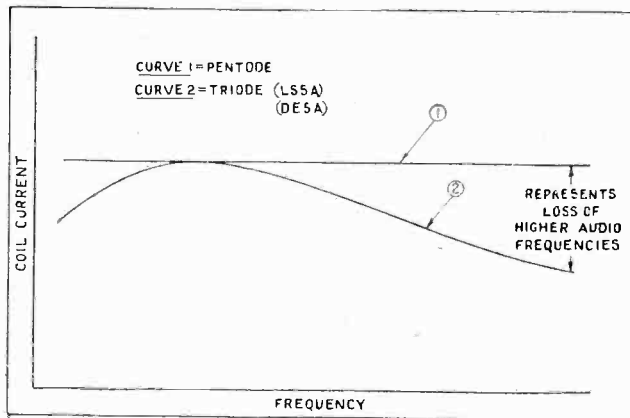

Fig. 8.—Diagram illustrating current through coil of loud speaker (1,000 turns) plotted against frequency. The curve extends to 8,000 cycles.

higher internal resistance of the latter. The curves of Fig. 13 indicate roughly the current variations with a triode of 3,000 ohms and a pentode of 33,000 ohms used in conjunction with a reed-drive loud speaker of 2,000 ohms nominal resistance. It is of interest to state that the amplification of the pentode at $f = 3,000 \sim$ is 40, an unusually large value for a power valve.

The performance of two reed-drive loud speakers and

The Output Stage and the Pentode.—

a coil-drive loud speaker have been tested on 2LO, 5GB, and 5XX. The receiver, when used with a power triode, had a uniform frequency characteristic, and the pentode in question was that reported on in the last issue of this journal. The three instruments tested were as follows: (1) "Kone"; (2) the author's cloth cone; (3) coil-drive with coil of

punishment simply did not fit the crime, and that is all there is to it. Using an LS5A valve there was a distinct difference. Both speakers exhibited more bass, whilst the musical instruments assumed their customary individuality. Moral! The loud speaker must fit the valve.

Input Impedance an Important Factor.

These experiments with reed-drive loud speakers can be viewed from another standpoint, namely, the effect of the pentode on preceding stages. Owing to the grid to anode capacity the pentode has what is commonly known as an "input impedance."² The input impedance is in parallel with the grid leak or transformer secondary, whichever coupling precedes the pentode. The grid to anode capacity includes that of the internal leads, also that in the valve holder and its leads. In our case the load in the anode circuit of the pentode is an inductance in series with a resistance, this being approximately representative of the loud speaker. The inductance causes the input impedance to be a negative resistance, which is in series with a condenser whose magnitude depends upon the degree of amplification exercised by the valve, and upon the grid to anode capacity. The negative resistance means that energy is being fed back from the pentode to previous stages. This, however, does not cause oscillation if precautions are taken. The con-

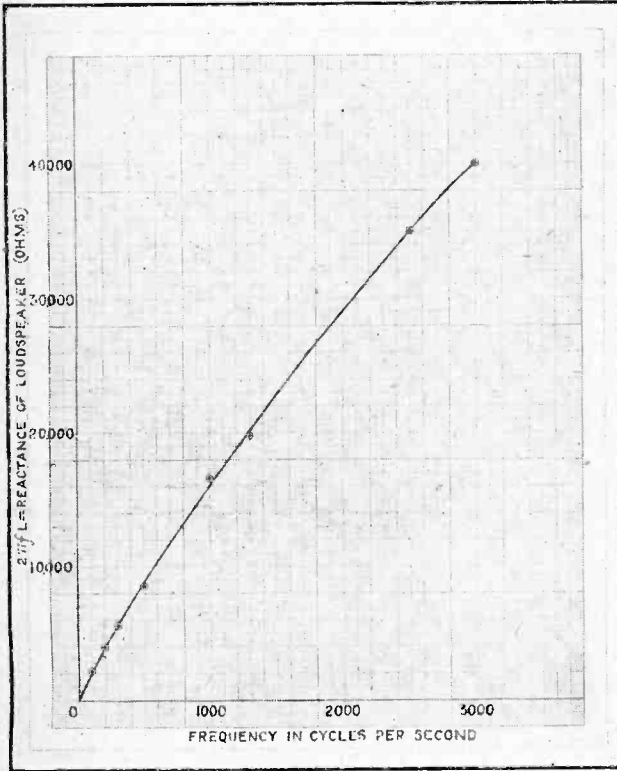

Fig. 9.—Experimental curve showing effective resistance of reed-drive loud speaker of 2,000 ohms nominal D.C. resistance.

1,500 turns and a magnetic field of 9,300 lines per square cm. The latter instrument was used as a standard of comparison. The results can be divided broadly into two categories (a) Loudness; (b) Quality. Tests were conducted with a pentode on the grand organ, orchestra, and speech. The cloth cone was decidedly the loudest, because its impedance (2,000 ohms nominal resistance) matched the valve most closely. The "Kone" came next, whilst the coil drive just lagged behind. Similar tests with an LS5A valve altered the order to coil-drive, cloth cone, "Kone."

Quality tests with the pentode confirmed the preceding comments, and were disappointing with the "Kone" and the cloth cone. In both cases the music seemed to play round a certain quarter of the frequency register, and there was a lack of definition. Individual instruments did not stand out. Throughout the tests the reproduction from the coil-drive was up to its usual high standard. *This must not be regarded as a criticism of either the reed-drive loud speakers or the valves.* The

¹ British specification 257,317. See Loud Speakers, p. 80, Fig. 46.

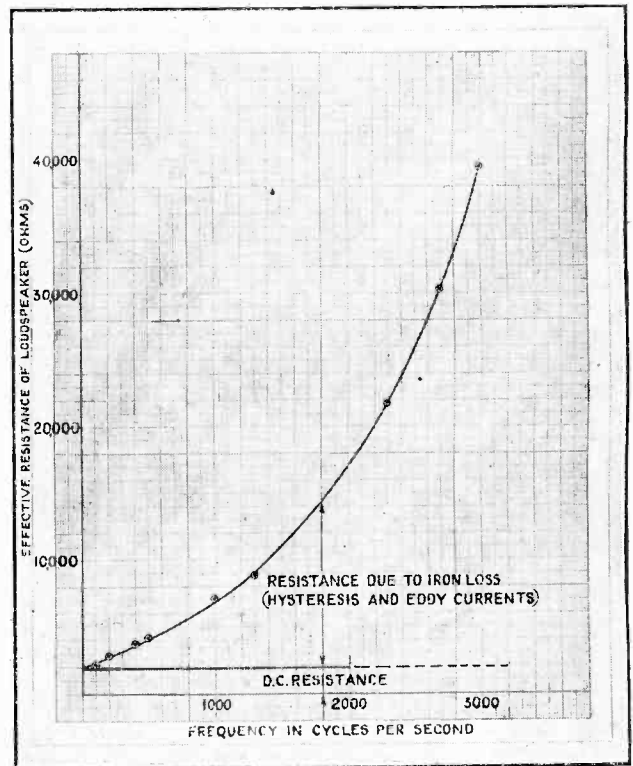

Fig. 10.—Experimental curve showing reactance of loud speaker of 2,000 ohms nominal D.C. resistance. Due to eddy currents in the iron the inductance decreases from 3.6 henries at 100 cycles to 2.2 henries at 3,000 cycles.

² See article in *The Wireless World*, January 5th, 1927.

The Output Stage and the Pentode.—

denser being across the grid and filament will attenuate the higher frequencies. The complete action due to combination of negative resistance and condenser is complex and varies with the frequency.

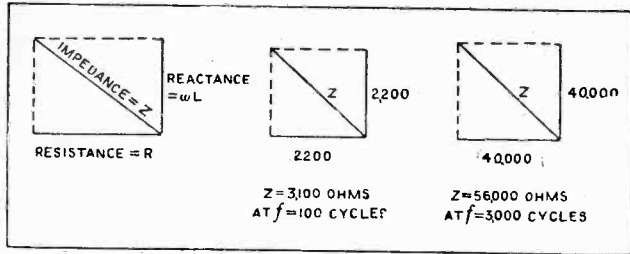

Fig. 11.—Loud speaker impedance is obtained by adding vectorially the resistance and reactance. The data apply to a reed drive.

In the present case the valve capacity is unknown,³ but some comparative tests throw light upon the point under consideration. Using a coil drive of 2,000 turns

ting 0.5 or 1 megohm in series with the grid and then adding the condenser.

Thus in using loud speakers of high impedance—this applies to a coil drive with 3,000 or 4,000 turns and valves of comparatively large capacity—the attenuation of the higher frequencies due to the input impedance of the pentode must not be overlooked. Of course if the pentode and its external connections have a capacity less than 1 $\mu\mu\text{F}$, the input impedance will be almost negligible for a coil of, say, 2,000 turns. To reduce the external capacity to a minimum an anti-capacity valve holder and careful wiring should be adopted.

Moving Coil Windings.

Generally speaking, it is policy to treat valves of high “m” value with caution. Just as input impedance prevents a gain of more than $\frac{1}{4}$ or $\frac{1}{3}$ the “m” value being obtained with an S625 valve, it limits our exploiting the pentode to its full extent where high quality and preservation of the upper frequencies are the main desiderata.

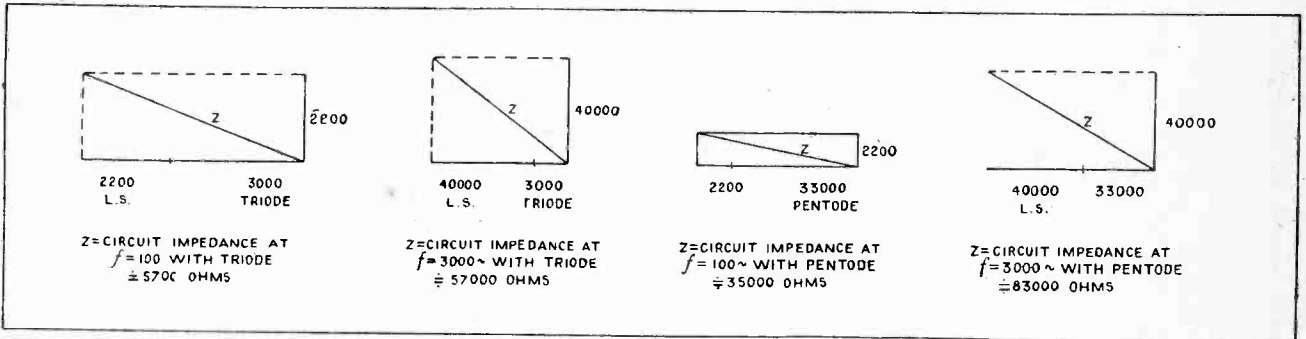

Fig. 12.—Circuit impedance at 100 and at 3,000 cycles with a triode of $\rho=3,000$ ohms and a pentode of $\rho=3,000$ ohms. Observe that the variation in impedance with the triode is 10/1, whilst with the pentode it is only 2.4/1.

with a pentode of $m=60$, $\rho=33,000$ ohms fitted in an ordinary valve holder, a condenser of 20 $\mu\mu\text{F}$ was connected between grid and anode. There was a decided loss in the upper frequencies, and the pedal organ lost its upper partials.⁴ Another test was made, using two pentodes in parallel, the wiring being rather extensive and adding capacity. Here again the upper frequencies were reduced appreciably.⁵

Input Impedance and High Note Loss.

Now in the above case the magnification due to the pentode would be from 15 to 20 at 4,000 cycles, whereas with a reed drive it would be between 40 and 50, i.e., 2.5 times as great. Moreover, the grid to anode capacity would be 2.5 times as important, so that a capacity of $\frac{2.0}{3.5} = 8$ cm. would be of considerable importance, i.e., it would attenuate the higher frequencies. In practice, however, with the “Kone” it was not found that the effect was as marked as these figures suggest. With both types of speaker the input impedance effect can be readily demonstrated by put-

So far as coil-drives are concerned, there is no reason to limit the number of turns to 1,000 as one must do when using triodes in order to retain the upper frequencies (large coil reactance). The high ρ value of the pentode makes it permissible to increase both the resistance and the reactance of the coil. By using

³ It is not suggested that the valve under test had an unduly large capacity.

⁴ See article in *The Wireless World*, Jan 5, 1927.

⁵ It is important to note that battery filters were used. Disconnection of the pentode screen filter resulted in blasting and bad quality due to L.F. reaction.

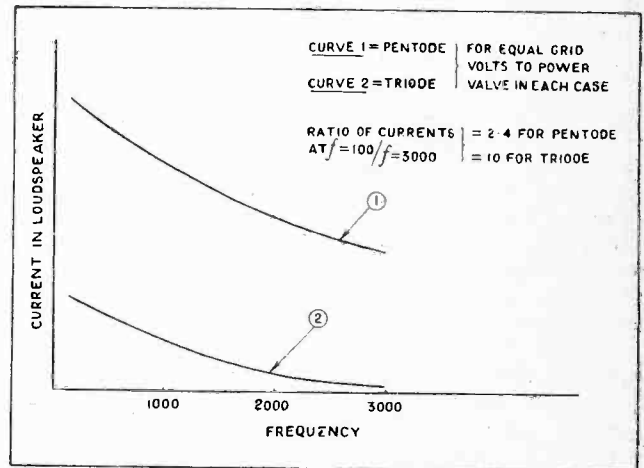

Fig. 13.—Diagram showing relative values of current in reed-drive loud speaker using pentode and triode. Observe the much greater variation in current with the latter valve.

The Output Stage and the Pentode.—

48 S.W.G. enamelled wire the numbers of turns can be increased appreciably. With 3,000 turns (if they can be accommodated comfortably in the air gap) the coil reactance at 5,000 cycles would be approximately equal to the internal resistance of the pentode. Provided the input impedance were negligible, the reproduction would be kindred in quality to that obtained to-day with 1,000 turn coils and LS5A valves, but the power out-

the permissible grid swing decreases with increase in the number of turns. Moreover, apart from coil and input⁷ impedance, there is an output limit due to the valve characteristic, i.e., when the non-linear portions are reached. This limit is also present with triodes, but can be raised for both classes of valve by augmenting the H.T. At the moment the H.T. limit for the pentode is 150 volts. As this is likely to be raised it would be premature to compare the maximum permissible output for triode and pentode (unlimited signal voltage).

As the reader may still be wondering how these large output currents are obtained with a valve of high internal resistance, a few additional remarks on the subject may be of interest. From Fig. 14 we see that the anode current for any given value of grid bias and H.T. is much greater than the corresponding current for a triode of similar internal resistance and amplification factor. This is purely a physical effect due to the design of the pentode. Moreover, since the triode and pentode are different in design and in their physical properties and behaviour, we must scrap our old ideas about high magnification factor and high internal resistance being incompatible for power purposes.

(To be concluded.)

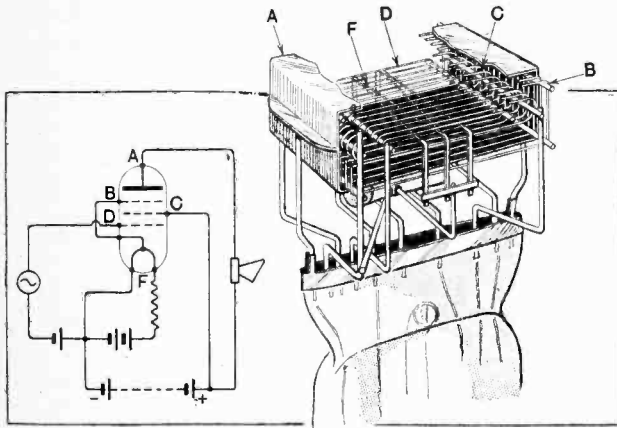

Diagrams showing the internal disposition of the electrodes in a typical pentode. A is the anode, B the auxiliary screened grid substantially at cathode potential. C the screened grid at same potential as +H.T. D the control grid.

put for a given signal voltage on the grid would be nine times as great. For better quality it is advisable to limit the number of turns to 2,000 or 2,500⁶ since the coil current will then be fairly constant throughout the audio-frequency range. With a coil of 3,000 turns the permissible grid swing would be less than that for a coil of 1,000 turns. This is due to the appreciable variation in anode voltage in the former case. Moreover, the anode voltage change must be kept within limits, so that only the linear portion of the pentode characteristics are employed. For example, in Fig. 4 (see page 32 of previous issue) the characteristic becomes curved at a smaller value of grid bias the lower the anode voltage (see curve 4 where the anode voltage is 60). Also the pentode magnification increases with the number of turns on the coil. Suppose the effective magnification were 30, the grid swing 5 volts and the H.T. 150 volts. Then since the change in anode volts = 5×30 the positive anode swing would be from 150 to 300 volts, and the negative swing from 150 volts to 0 volts. A swing of this magnitude would probably introduce distortion, whilst a greater swing would be inadmissible because the anode voltage cannot be reduced below zero. In order to determine the permissible swing with 3,000 turns, it would be essential to take a further series of characteristics for anode voltages well above and well below 150 volts and plot a valve-coil impedance diagram. At any rate, although 3,000 turns enhances the sensitivity enormously, the maximum possible output is limited, and

⁶ A valve resistance of 33,000 ohms is assumed. With a lower valve resistance the number of turns would have to be reduced accordingly.

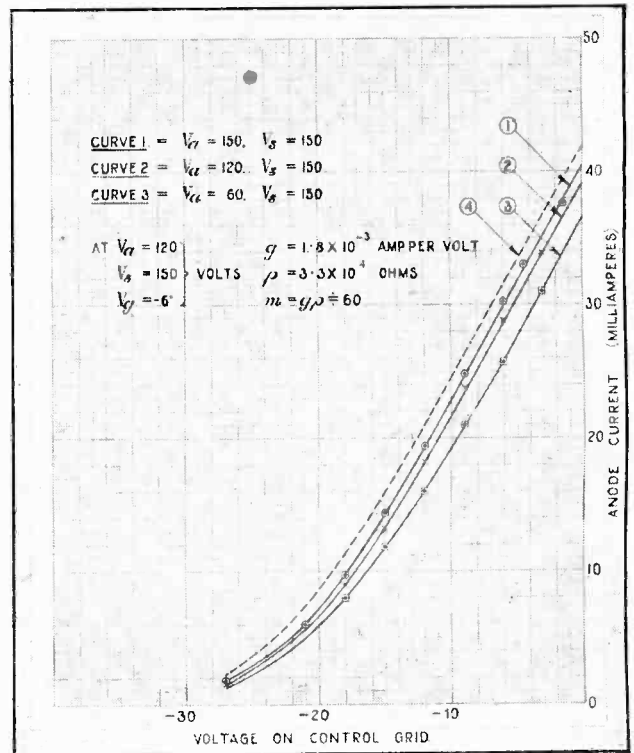

Fig. 14.—Grid volts-anode current curves or "conductance" curves of a two-volt pentode (P.M.22). The dotted curve (4) represents the characteristic when the anode voltage is higher than the screened grid voltage.

⁷ The input impedance depends, of course, on the character of the apparatus preceding the pentode. The above data relate to an average case. By alteration in design the effect could have been reduced considerably.

Armchair Wireless.—

the lead shown as being joined to the slider may sometimes be connected to L.T. negative.

If the resistance of the remote rheostat R_2 is increased, volume will be reduced, both by virtue of the fact that the voltage drop across it (and consequently the detector negative grid bias) is increased over and above that required for most sensitive detection, and also because the internal A.C. resistance of the valve is increased, due to dimming of its filament.

When making initial adjustments, it will be convenient to set R_2 at minimum resistance, and then, with the help of a voltmeter connected across the detector valve filament terminals, to fix its L.T. voltage at the full rated value by adjusting R_1 . Finally, the potentiometer slider should be moved to the position giving loudest signals—generally quite near the negative end of its winding.

The volume control must not be expected to deal with altogether excessive signal voltages from the aerial; where such conditions exist it is necessary to reduce the

input (by detuning or otherwise) to a reasonable level before putting it into operation.

In other words, the alteration of sensitivity, while sufficient to vary signal strength (in a detector-L.F. set as shown in the diagram) between the limits of full output from a super-power valve and an unintelligible whisper, is insufficient when, say, an H.F. voltage of 5 or 6 volts is developed across the grid-filament circuit. It is recommended that the input from the aerial should be so adjusted that volume on average modulation is slightly excessive when the distant control rheostat is "all out."

Although the control of volume is continuous, it is not in direct proportion to the setting of the rheostat dial; as it is rotated from zero there is at first little change in intensity, as the emission of the modern valve filament is generally so liberal that there is no appreciable reduction in amplification until its heating current falls off very considerably. As the resistance is further increased, however, a point is reached where both decreased emission and increased negative bias come into play.

USEFUL DATA CHARTS. (No. II.)

Inductance, Capacity, and Frequency: Short-wave Band.

The wavelength to which a tuned system comprising a coil and a condenser responds is given as follows: microhenries \times micro-microfarads = metres² \times 0.281. This is of the form $a \times b = 0.281 \times c^2$, so that three equal logarithmic scales are required. The middle scale is fixed by cutting off a length extending from 10 to 100 metres, which is generally recognised as comprising the short-wave region. The capacity range required is about 7 to 100 micro-microfarads, and so the right-hand scale is fixed. It now remains to put the left-hand scale in position. A line is drawn joining $40\mu\text{F}$ to 30 metres: then microhenries $\times 40 = 0.281 \times 30^2$, which gives 6.32 microhenries as the point where the line should intersect the left-hand scale.

The L/C Ratio.

In considering the values of inductance and capacity to be adopted in short-wave receiving circuits, we must be sure that our choice leads to a really efficient circuit since we are limited in the use of H.F. amplification. For the grid input circuit the use of large L and small C will increase signal strength provided that a loosely-coupled aerial is used and that the detector does not load the circuit unduly. If these two conditions are not fulfilled then better results will be obtained by designing the circuit to give the greatest output under a definite load.

When working above, say, 5 megacycles, it is desirable that the variable part of C should be fairly small and become smaller as the frequency is increased, since the band traversed by the condenser becomes greater as the frequency increases.

It is convenient to use a variable condenser of maximum capacity $0.00075\mu\text{F}$ with a parallel fixed condenser so as to bring the total maximum capacity of the circuit up to $0.001\mu\text{F}$; this will give, in conjunction with a suitable coil, a tuning range of approximately 5 to 7.5 megacycles. The abac shows that at 5 megacycles with

the condenser all in $10\mu\text{H}$ will be required, and that at 7.5 megacycles the capacity must be reduced to $0.00045\mu\text{F}$.

Short Wave Tuning Ranges.

This is as much as we should attempt to cover at this point, and it is preferable to decrease the range of the condenser as the frequency gets higher, as stated above. A short table of a suggested series of convenient ranges is given, and it should be pointed out here that the ranges mentioned are covered in rather less than the swing of the dial so as to give a certain amount of overlap at the ends.

Range in Megacycles.	Range in Metres.
5.0-7.5	60-40
7.5-10.0	40-30
10.0-12.0	30-25
12.0-13.5	25-22.2
13.5-15.0	22.2-20
15.0-16.0	20-18.75

If the maximum value of the variable condenser is decreased as the frequency is increased, it will result in a shortened range as desired, since its ratio to the fixed capacity is decreased. There are several methods of achieving this end, one being to use two similar variable condensers in tandem, connecting them first in parallel, then singly, and finally in series. The calculation of the effective value of two condensers in series can be avoided by the use of an abac which will appear later in this series.

Another method is to put a fixed condenser of suitable value in series with the variable part. It should be borne in mind that the addition of a fixed condenser will alter the law of the tuning scale, and if it was originally "straight-line wavelength" it will approximate to "straight-line capacity" with the series condenser.

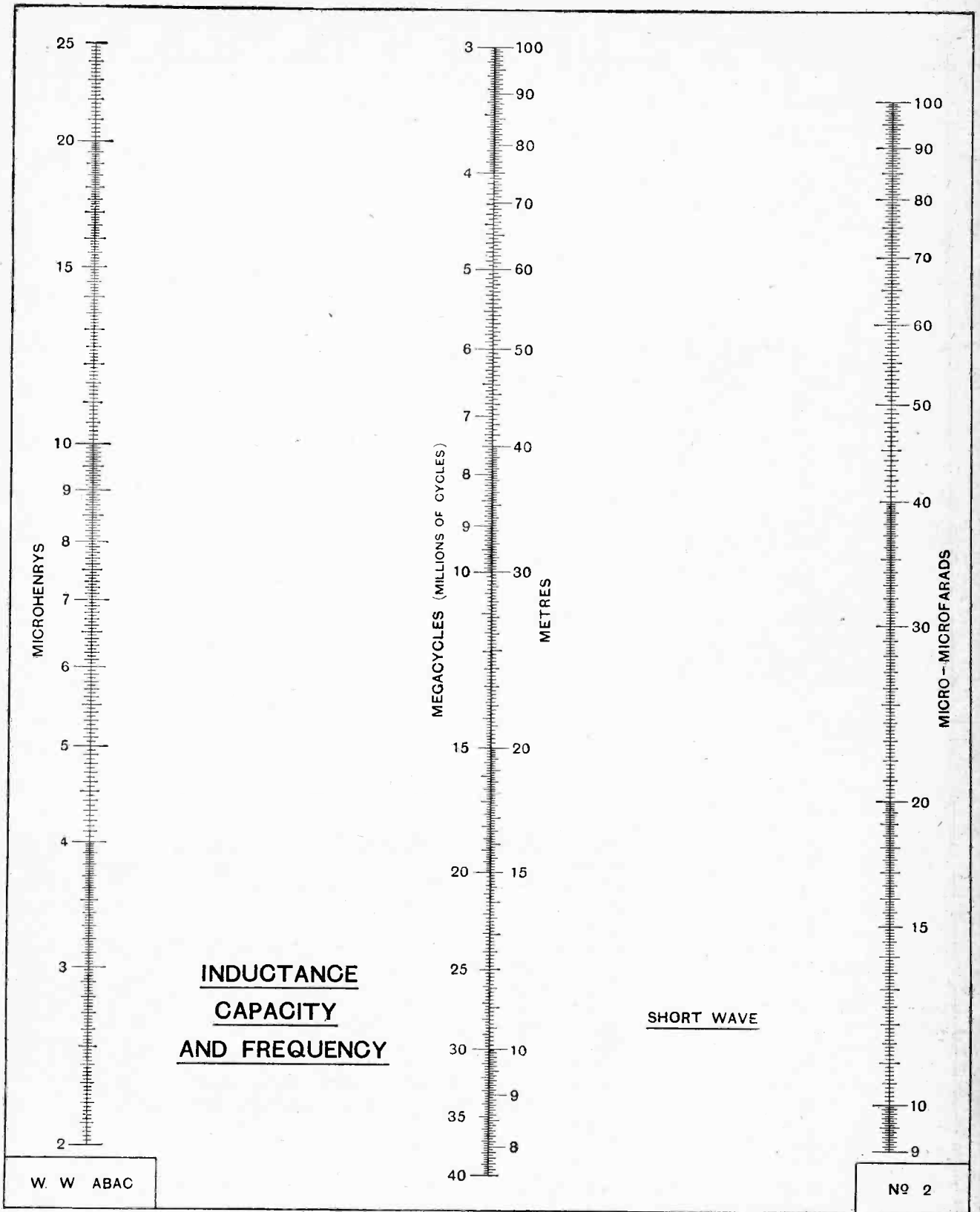



CLUB REPORTS AND TOPICS

Making the Most of Summer.

The "cussedness" of British weather has taught us to partake thankfully and plentifully of anything which resembles sunshine: thus the majority of wireless clubs are now holding their meetings in the open-air. One of the most exciting and instructive games ever invented—the D.F. hunt with portable receivers—is now being played in various parts of the country, and among the societies which have already carried out field days of this kind are the Golders Green and Hendon Radio Society (in collaboration with other London societies), Southend and District Radio Society, North Middlesex Radio Society, Slade Radio (Birmingham), Bradford and District Radio Society, and the Sheffield and District Wireless Society.

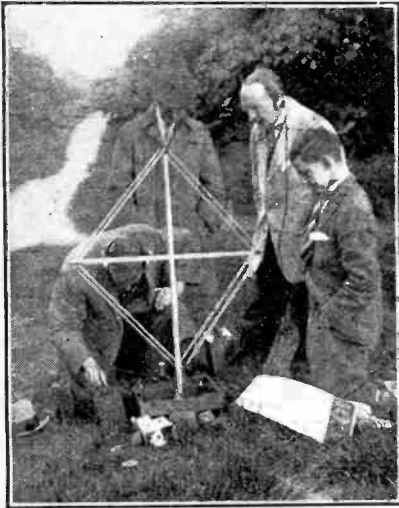

ON THE SCENT. One of the parties which took part in the recent concealed transmitter hunt organised by the Sheffield Wireless Society.

Wireless Golf?

The D.F. hunt contains all the elements of competition present in other games with many peculiar qualities possessed by no other pastime. The boundaries of play are only limited by the travelling capacity of the players, and if time did not enter into the question, the whole of the United Kingdom could be brought into the game. A number of hidden transmitters scattered up and down the country could be tracked in turn, and the game would then develop into a sort of wireless golf, the players representing different radio societies in competition. And even if time does not permit of play on such a large scale, there seems to be no reason why several transmitters could not be used on one field day, especially if each tracking party is provided with a car. ○○○○

Tracking a Moving Transmitter.

Whether the game would benefit by the introduction of complications is a moot question. Tracking a mobile transmitter in the manner attempted by the Golders Green and Hendon Society on Sunday last (July 15th) may involve many exciting situations, but there remains the danger that the hunt for a moving object may develop into a simple chase at speeds considerably above the legal limit. ○○○○

Concealed Transmitter in Peak District.

Members of the Sheffield and District Wireless Society recently spent an exciting day in tracking a concealed transmitter in the Peak district. Four parties, each provided with a portable receiver and frame aerial, proceeded to four points of the compass relative to the concealed transmitter, each being unaware of

course, of the locality of the other three parties. The transmitter worked on a wavelength of 200 metres, and started transmissions at 11 a.m., working with intervals of five minutes till 11.25. Transmission was resumed at 12.15 p.m., the same signals being transmitted in the same sequence until 12.40 p.m. The concluding transmission was begun at 2 p.m. the same schedule being observed.

The winning party under the direction of Mr. Raynor had instructions to proceed to Moscar Lodge, a wild moorland spot, situated approximately eight miles north of the transmitter. Their receiver was a two-valve Hartley with a split aerial wound round the frame. At Moscar Lodge signals were faint but clear, and a complete cut-out was obtained with the frame at minimum. Bearings having been plotted and a line drawn on the map, the party proceeded to the village of Windmill. Here signals were very much stronger and the bearing so definite that a line was quickly plotted on the map, and the party rushed off to Poolow, a village a few miles east where a further set of signals came in strongly. ○○○○

Caught in the Act.

During the lunch interval it was discovered that the three lines drawn did not give a true intersection but formed a small triangle roughly half a mile square. The party, therefore, proceeded to a point in the centre of this triangle and here, during the final transmission, signals were deafening and difficulty was experienced in detecting the exact minimum position of the frame. In a few minutes the transmitting party was caught in the act of sending out the last series of signals from an old farmyard concealed behind a coppice. At the conclusion of the transmission all parties proceeded to "Woodville," Hope, the home of Mr. Jake-man. Here, during refreshments, the adventures of each of the parties were discussed. No other party succeeded in locating the transmitter. One party showed a better set of bearings on their map than the winning party, but transmissions ended before they could again check and reach the point of transmission. Another party could not get down to the wavelength of the transmitter owing, it was discovered, to the capacity effect of a band of American cloth used to simplify handling the receiver.

The transmitter was a loose-coupled Hartley single valve at 500 volts 30 milliamperes, i.e., 15 watts with a 0.3 amp radiation. The aerial was 20 feet high, and the counterpoise consisted of a single wire 4 feet above the ground.

Hon. secretary, Mr. T. A. W. Blower, Cannonfields, Hathersage, Sheffield.

○○○○

"Hare and Hounds" in North Middlesex.

A radio "hare and hounds" scheme carried out by the North Middlesex Radio Society on June 23rd was a great success. The "hare"—a hidden transmitter—employed the familiar loose-coupled Hartley circuit working on a wavelength of 190 metres. An LS5 valve with 188 volts on the plate took 18.5 milliamperes and an aerial current of .2 amps was obtained. In the circumstances a somewhat impromptu aerial was used. This and the counterpoise each consisted of 75ft. single wire.

At 3.15 p.m. three parties of "hounds" set off with maps to prearranged spots, and took their first bearings at 3.20 p.m. The portable receivers were all 2-valve sets (Hartley circuits), two of them with built-in frame aerials. The winning party located the transmitter after the sixth transmission at 5 p.m., the leader of this party being Mr. Tagent. The hidden transmitter was located in a field behind an inn in a very inaccessible spot. A further transmission brought the second party to the spot, and at the conclusion of the proceedings the third party was found only a few hundred yards distant from the "hare."

From the experience gained several important points were elicited. These could be summarised as follows:—

1. Use a frame built in the portable receiver.
2. Use a compass.
3. Avoid telegraph wires or masses of metal such as the chassis of a car.
4. Where possible, take bearings near crossroads.
5. Don't mistake the chirping of birds for the transmitter!

The transmitter was in the charge of Mr. L. C. Holton (2S1), assisted by Messrs. Chapple, Kirlaw, and Crowh.

Hon. secretary, Mr. E. H. Laister, "Endcliffe," Station Road, N.21.

○○○○

Short Waves and the Moon.

At the meeting to-morrow (Thursday) of Slade Radio, Birmingham, Mr. Derek Shannon will read a paper on the effect of the moon on short-wave reception.

Hon. secretary, Mr. H. Clews, 52, St. Thomas Road, Erdington, Birmingham.



THE END OF A PERFECT DAY. Members of the Sheffield Wireless Society photographed at the conclusion of the recent transmitter hunt, in which only one party was successful. On the left is the transmitter—a loose-coupled single-valve Hartley. The portable used by the winning party can also be seen.

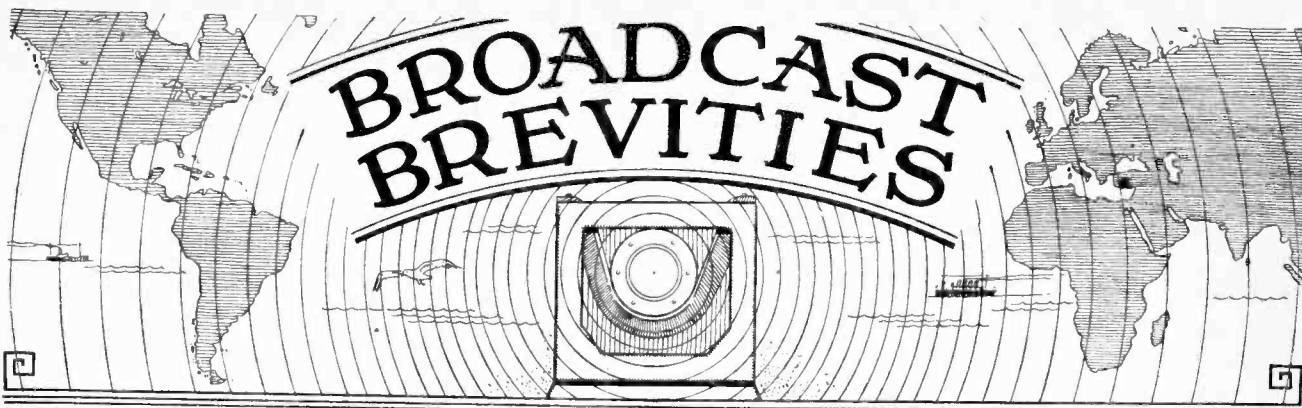

By Our Special Correspondent.

Closing Down the Relays.—A Plea for “Maniacs.”—School Wireless: The Carnegie Report.—The Promenade Concerts.

The Relay Stations.

Speculation has been busy recently regarding the future of the relay stations. There can be little doubt that the autumn and winter will see some surprising changes in programme distribution, as a prelude to the regional scheme. I hear that it is very unlikely that the Corporation will wait until the completion of the regional stations before reducing the number of stations now in operation.

Savoy Hill is already making plans for the distribution of the staff of one relay station which will certainly have finished its existence before the end of the year.

The Ideal: Studios Everywhere.

All the present relays will cease to function as wireless stations with the introduction of the regional scheme. In most cases, however, the studio will be retained and there is a probability that new studios will be erected in towns which have never boasted a broadcasting station, either main or relay.

The ideal would be for each city to have its broadcast studio connected to the nearest exchange point. There would then be no complaints that Glasgow had an unfair advantage over Edinburgh or that Blackpool could shout its charms more easily than Brighton.

A Plea for the “Maniacs.”

If the B.B.C. refuses, in spite of the lifting of the ban on controversy, to place the microphone at the disposal of vegetarians, spiritualists, anti-vaccinationists, anti-vivisectionists, and other ardent propagandists, care should be taken to avoid hurting their susceptibilities. If they could “answer back” it would be a different matter, but the microphone is banned to them.

Yet the Corporation’s official organ, commenting on a cookery talk on July 11th, says: “Most of us have known, and suffered from, the diet maniacs—vegetarians, fruitarians, enthusiasts for vegetable marrows and nut outlets and artificial simulations of meat . . .”

“Maniac” is sometimes a useful word,

but its use in the passage referred to has given offence to the vegetarian community. I think that the least Savoy Hill can do now is to allow them a talk in self-defence.

o o o o

School Wireless Investigated.

There are now two distinct spheres of educational broadcasting, one of which

from the pages (there are 124 of them) in a report on “Educational Broadcasting” published by the Carnegie United Kingdom Trustees. The report deals with a special investigation carried out in schools of the county of Kent during 1927, and—a point of paramount importance—gives the opinions of teachers themselves on the value of broadcast lessons.

o o o o

The Teachers’ Verdict.

School teachers are nearly unanimous (I judge by the report) as to the benefits which broadcasting can confer under favourable conditions. Their opinions, canvassed by a diligently-prepared set of questionnaires upon each individual course, may be summarised as follows:—The broadcast lessons in 1927 (a) imparted a knowledge of facts; (b) stimulated interest in ways which could be definitely observed; (c) created impressions as durable as those produced by their ordinary lessons; (d) did not encourage inattention; (e) were particularly stimulating to clever children; (f) supplied views and information which the teachers could not have supplied, and (g) gave them fresh ideas for lessons.

o o o o

Another Report Wanted.

An additional blessing seems to have been the added interest which many parents have displayed in their children’s lessons. In some cases Dad has been able to listen to the same lesson that Tommy has heard while in school, and poor Tommy has come home to an unexpected parental catechism.

I should like to hear what Tommy thinks about it. When shall we have the children’s report?

o o o o

The “Prom” Season.

All music lovers will welcome the extension of the B.B.C. Promenade Concert season to eight weeks this year as compared with six weeks in 1927. The season will open at the Queen’s Hall on Saturday, August 11th, under the conductorship of Sir Henry Wood.

FUTURE FEATURES.

London and Daventry.
 JULY 22ND.—Bach Cantata relayed from St. Ann’s Church, Manchester.
 JULY 23RD.—An All-Welsh Concert relayed from the New Theatre, Cardiff.
 JULY 25TH.—“Improvisations in June,” by Max Mohr.
Daventry Experimental (5GB).
 JULY 23RD.—A Norman O’Neill Concert.
 JULY 24TH.—“Improvisations in June,” by Max Mohr.
 JULY 27TH.—Surprise Feature.
Cardiff.
 JULY 27TH.—“Superstition,” a play in one act by Martin Lane.
Manchester.
 JULY 24TH.—“Marjory,” a comedy with music in three acts.
 JULY 26TH.—“Peter Calling,” a wireless mystery in three scenes by West Thorpe.
Newcastle.
 JULY 24TH.—Concert by the Municipal Orchestra directed by Frank Gomez.
Aberdeen.
 JULY 25TH.—Scottish Concert.

comes in for a good deal more criticism than the other. Most of the brickbats are aimed at the “adult” education schemes of the B.B.C., but there is little evidence of any pronounced antagonism to the efforts which are being made to extend broadcast lessons in schools.

If encouragement were needed in this direction, Savoy Hill can take its fill

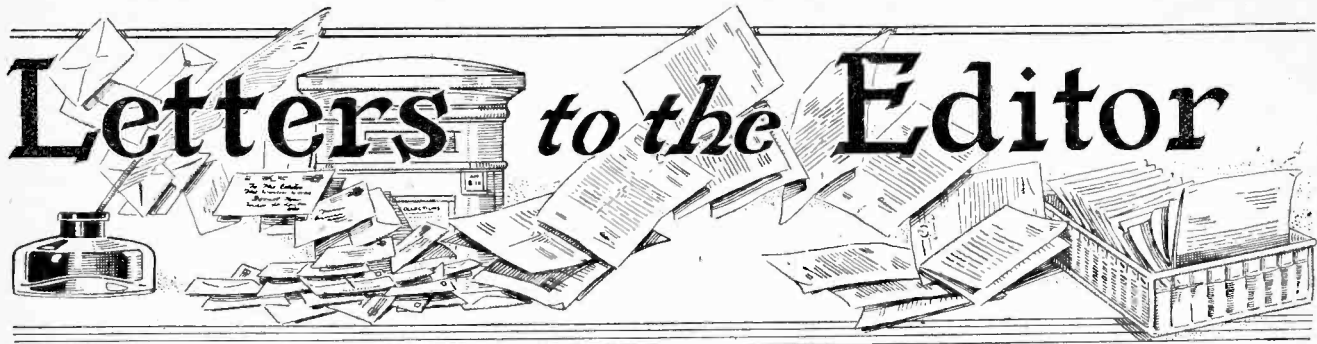

The Editor does not hold himself responsible for the opinions of his correspondents.

Correspondence should be addressed to the Editor, "The Wireless World," Dorset House, Tudor Street, E.C.4, and must be accompanied by the writer's name and address.

MOVING-COIL REPRODUCTION.

Sir,—I have read with great interest the letters recently published on moving-coil reproduction, especially the letter of Mr. L. C. Hill.

There seems to be a great difference of opinion as to whether a moving-coil speaker will operate from a single output valve of the 256 type.

Perhaps my experience will be of assistance to your readers. Following *The Wireless World* design—it is essential to employ the large pot—for those using a 6- or 8-volt accumulator, a high-resistance winding can be easily accommodated in the narrow gap (5/64). I wound 1,400 turns of 47 wire. This gives excellent results, and seems invariably better than matching the low-resistance coil and transformer.

With regard to the set. For those who can receive intelligible speech on a crystal, they will find that a three-valve set (bottom bend detector, no reaction, resistance and transformer coupled, with 256 output valve) will give ample volume for an average sized room. It is essential to use 160 volts on the last valve, as below this voltage "chattering" is experienced. In this respect one cannot do better than follow Mr. Hill's suggestions. The above combination will give results which, I think, would satisfy the most critical listener.

Malvern.

F. W. SANTLER.

July 4th, 1928.

ALTERNATIVE PROGRAMMES.

Sir,—The pronouncement by the Postmaster-General that he has no idea of the final details of the Regional Scheme gives opportunity for suggestions.

The British broadcasting station having the greatest range, suffering the least interference, and listened to by the largest number is very easily 5XX, the long-wave Daventry station. That this station should broadcast almost precisely the same programme as 2LO, over the area where this latter is effective, is highly ridiculous, as it should very obviously supply the alternative, and any different programme for the Midlands, even though it be the same as for London, could come from the "alternative" station, 5GB, which ought to be effective in satisfying even Continental listeners if their requirements are to be considered. As it is, 5XX is not of much use to Northern listeners, as their own stations mostly give out London programmes, and such items as they would conceivably like more than others (as, e.g., the local news from London) Daventry does not supply. No doubt a plea for the crystal user will be brought forth in excuse, but many crystal users are able to obtain both 2LO and 5XX, and, in any case, provided the crystal user can get one station, surely the man with sufficient enthusiasm to get or make a valve set (British valves can now be got from 3s. 6d. up) deserves some extra consideration.

Give, therefore, a distinctive programme (with an Empire favour if you like) to 5XX, and since only one long wavelength is available for the British Isles, erect a precisely

similar station in Scotland for that area, giving precisely the same programme as 5XX on exactly the same frequency. Lest a howl on the subject of heterodyning go up, let us point out that such synchronising has been tried in America with most excellent results, and to do this here might avoid the expense of aerial shorter wave stations as alternatives.

Manchester.

EX-LONDONER.

"GIFT HORSES."

Sir,—Reading through the copies of *The Wireless World* that have accumulated during a sojourn in the St. John's Hospital, Lewisham, the above-headed topic has appealed to me, as I have experienced disappointment at the inefficiency of the wireless installation.

As inscribed on the headphone bands, the *Daily News* in 1925 installed the apparatus. It was tuned in permanently to 2LO. The trouble, in my ward, was due to faulty 'phone leads, and, in some cases, in the telephones. In one or two cases, by the aid of a penknife, I was able to effect temporary repairs.

If something can be done to bring these faulty installations up to the mark again I can assure you that the sick people in hospitals will be very grateful.

One needs to be bedridden to appreciate broadcasting to the full.

Catford, S.E.6.

F. JAMES.

June 12th, 1928

A STRAIGHT-LINE INTERVALVE COUPLING.

Sir,—I have read with interest the letters of Messrs. Sowerby and Turner on the moot question of rectification, and find myself in agreement with the former gentleman. The all-important factor in all these questions (and one that is almost invariably overlooked) is the time-constant and its effect on grid saturation. The less of this the better chance we have of realising our ideal, viz., faithful reproduction. The one great barrier to this realisation is the non-inductive grid leak, which, as everyone knows, is a fruitful source of saturation both in the high- and the low-frequency side of a receiving circuit. The diminution of the time-constant caused by working the detector valve off its bottom bend is a factor by the side of which all others pale into insignificance. It is mainly for this reason that people endowed by nature with ultra-sensitive ears prefer anode to grid rectification. From the standpoint of efficiency in dealing with weak signals anode rectification needs only to be backed by efficient high-frequency amplification to hold its own with any leaky grid arrangement. The latter method is only of service in cases where it is desired to secure the maximum of efficiency from a "detector-Reinartz" circuit which depends on reaction for the amplification of weak signals. But to quality seekers anode bend is a *sine qua non* unless diode rectification is tried. The latter method is in reality a somewhat "hair-splitting" proposition, as the tym-

panic membrane of the human ear is asymmetrically loaded, and, therefore, does not possess a straight-line characteristic.

But the matter does not end here. However perfect your rectifier, it is equally important to reduce the time-constant to a negligible factor in the audio-frequency amplifier. So far the only serious attempt at solving this problem has been made by Professor Donle. He substituted chokes for grid leaks. This was a step in the right direction, but when it was discovered that a serious low-note loss resulted unless the chokes were made so large that self-capacity was introduced, people reverted to the old grid leak. It is the same with transformer coupling. Either you get too much capacity, or else you lose your low tones. A transformer in the last stage preceded by some form of resistance-condenser coupling is an

excellent thing, but saturation is very marked in loud passages. If the push-pull system is used, we obtain really splendid results provided the overall amplification is kept down to a datum point. Beyond that point a middle hump develops which destroys all the advantages claimed for the system. The problem of problems is how to preserve a uniform amplification of all audio-frequencies with a really good soaring efficiency curve and free from saturation trouble. Is there no form of coupling that solves the problem? Experiments I am now carrying out show considerable promise of success, and I have already applied for provisional protection for a new coupler which, for the reasons above enumerated and explained, marks a distinct advance on all previous systems.

Hampstead, N.W.6. NOEL BONAVIA-HUNT, M.A.

MAINS CONNECTED RECEIVING SETS.

New I.E.E. Regulations.

The following new sections concerning the use of radio apparatus connected to the supply mains have now been added to the Regulations governing the electrical equipment of buildings.

129. Protection of Live Parts.—All parts (including the terminals and connections of batteries) which are alive or are intended to become alive from the supply mains shall be so guarded as to prevent accidental contact with such parts under normal conditions of use.

130. Construction of Cases.

(A) Where the apparatus is enclosed the containing case shall be substantially constructed and shall be of (a) metal or non-ignitable material, (b) mahogany, teak, oak (English) or walnut, or (c) other material if a non-ignitable and non-hygroscopic lining is used. All holes for the passage of cables shall be so made as to avoid abrasion of the cables.

(B) Any containing case made of conducting material shall be earthed in accordance with Regulations 101 and 102, and shall be provided with a suitable terminal for that purpose.

(C) The apparatus shall be so proportioned and installed that under normal working conditions no part of it can rise to such a local temperature as will impair its durability, and that the general temperature of the air inside the main containing case does not exceed 120° F.

131. Protection against Excess Current.—The apparatus shall be adequately protected by fuses on both poles of the circuit supplying it. The size of such fuses shall be based on the normal working current of the apparatus, provided that where the working current is less than 2 amperes no fuse smaller than No. 25 S.W.G. lead-tin alloy need be used.

132. External Cable Connections to Radio Apparatus.—Where the conductor of any cable connected to a radio apparatus is in direct connection with the supply mains, such cable shall be of one of the types specified in Regulations 76 to 81 and shall be installed in accordance with Regulation 87.

133. Isolation from Supply Mains.

(A) *Earthing Lead.*—There shall be no connection, except through a condenser, between any conductor directly connected to the supply mains and the earthing lead of the radio apparatus which is connected to the earth plate, waterpipe or other earthing system. The above condenser should preferably be incorporated in the radio apparatus or should be placed as close as possible to it.

(B) *Aerial.*—Where radio apparatus is connected to *direct-current* supply mains the aerial shall only be connected to the apparatus through a double-wound high-frequency coupling transformer adequately insulated for a test pressure of 600 volts, or through a condenser inserted in series with the aerial circuit and immediately adjacent to the aerial terminal. The above transformer or condenser should preferably be incorporated in the apparatus or should be placed as close as possible to it.

Where radio apparatus is connected to *alternating-current* supply mains without the use of a double-wound "mains" transformer, the aerial shall be connected as described above, but the condenser referred to shall have a capacity not greater than 0.001 microfarad.

For either *direct-current* or *alternating-current* supply, the insulation-resistance test specified in Regulation 136 A shall be applied to the high-frequency coupling transformer or to the condenser, whichever be employed.

(C) *Head Telephones and Loud Speakers.*—These shall be connected to the radio apparatus either through a double-wound transformer or, alternatively, through a circuit which includes a condenser in series with each of the outgoing conductors.

NOTE.—The field circuit of a moving-coil loud speaker having a separately excited field system may be independently connected to the supply mains in accordance with the Regulations which are applicable.

134. Condensers.—The condensers referred to in clauses (A), (B) and (C) of Regulation 133 above shall conform in all respects to British Standard Specification No. 271—1926 and shall be of either the mica-dielectric or the paper-dielectric type mentioned in that Specification for use in circuits in which the pressure does not exceed 300 volts (600 volts direct-current test pressure).

135. "Mains" Transformers.—Every "mains" transformer shall have its core earthed, and shall be of the double-wound type in which the winding that is in direct connection with the supply mains is effectively separated from all other windings either by an earthed metallic screen or by adequate insulation capable of withstanding a test pressure of 1,000 volts (alternating current). The insulation resistance between the above winding and all other windings, when measured after the above pressure test, shall be not less than 20 megohms when tested with a pressure of 500 volts (direct current) or twice the supply pressure, whichever be the greater.

136. Insulation Resistance.

(A) The terminals or points at which the aerial, earth, and telephone or loud speaker connections are made to the radio apparatus, or to the transformers or condensers referred to in Regulation 133 where these are external to the apparatus, shall have an insulation resistance from the "mains" input terminals of the apparatus of not less than 2 megohms when tested with a pressure of 500 volts (direct current) or twice the supply pressure, whichever be the greater.

(B) Every battery connected to the radio apparatus and intended to be in metallic connection with the supply mains shall be adequately insulated so as to have an insulated resistance from earth of not less than 2 megohms, when tested as specified in (A) above.

READERS' PROBLEMS

"The Wireless World" Supplies a Free Service of Technical Information.

The Service is subject to the rules of the Department, which are printed below; these must be strictly enforced, in the interests of readers themselves. A selection of queries of general interest is dealt with below, in some cases at greater length than would be possible in a letter.

Milliamps on an Ammeter.

Is it possible to convert my moving coil ammeter to read milliamperes by the insertion of resistances in series, or if this is not practicable, by any other means?

T. C.

You are in error in supposing that an ammeter can be modified to read currents in the order of milliamperes by inserting series resistance. In any case, without full particulars of your instrument it is not possible to give any definite advice, but in all probability its sensitivity may be increased by either removing the existing shunt resistance entirely, or if necessary, by replacing it by one of a higher value. You could experiment on these lines.

○○○○

Not According to Plan.

I have added a separate rheostat for the H.F. amplifier of my receiver with the idea of using it as a volume control. Unfortunately, however, this does not work as it should, but in exact opposition to the manner I had expected. On putting in circuit a few ohms of resistance signals become louder instead of weaker; a slight further increase puts the set into oscillation. Can you suggest a reason?

L. T. D.

The effect you describe is unusual, but we think it might be accounted for by the fact that the added resistance is connected in circuit in such a way that it is common to two or more circuits, and it is thus acting as an interstage coupling. Again, it may be that your filament and grid return circuits are so arranged that the insertion of resistance decreases the normal positive bias (possibly applied inadvertently) to the H.F. grid (or grids). If you care to send us a circuit diagram of your set we will endeavour to offer a more definite opinion.

○○○○

Throttle Control of Reaction.

Will you please give me a circuit diagram showing how I can modify my present "Hartley" detector circuit for throttle control, of which I hear good accounts? I am told that an H.F. choke is not essential; if this applies to my receiver, in which the detector is coupled by a resistance to the first L.F. amplifier, I should prefer to dispense with it.

A. M. S.

The circuit you require is given in Fig. 1, in which C_1 is the reaction feed con-

denser and C_2 the throttle control. C_3 and C_4 are the usual grid condensers for detector and L.F. valves. C_2 may be of from 0.0003 or 0.0005 mfd., while a capacity of 0.0001 will be ample for C_1 ; if

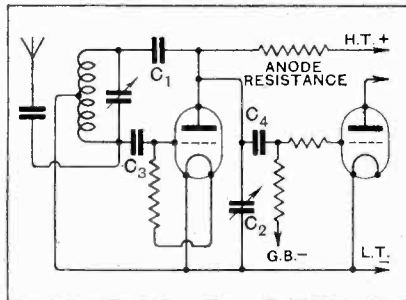

Fig. 1.—A throttle controlled reaction circuit in which the anode resistance acts as an H.F. choke.

the valve tends to oscillate too freely, this should be reduced. A fairly low value of anode resistance (not more than 100,000 ohms) is recommended for a circuit of this type.

RULES.

- (1.) Only one question (which must deal with a single specific point) can be answered. Letters must be concisely worded and headed "Information Department."
- (2.) Queries must be written on one side of the paper, and diagrams drawn on a separate sheet. A self-addressed stamped envelope must be enclosed for postal reply.
- (3.) Designs or circuit diagrams for complete receivers cannot be given; under present-day conditions justice cannot be done to questions of this kind in the course of a letter.
- (4.) Practical wiring plans cannot be supplied or considered.
- (5.) Designs for components such as L.F. chokes, power transformers, etc., cannot be supplied.
- (6.) Queries arising from the construction or operation of receivers must be confined to constructional sets described in "The Wireless World" or to standard manufacturers' receivers.

Readers desiring information on matters beyond the scope of the Information Department are invited to submit suggestions regarding subjects to be treated in future articles or paragraphs.

A Substitute for Litz.

In order to reduce cost I wish to wind my H.F. coils (on the lines of those described in connection with several "Wireless World" receivers) with solid D.C.C. wire instead of Litz. Which gauge do you recommend for best possible results on the normal broadcast wavelengths? N. L. C.

The gauge of wire for lowest H.F. resistance depends on the diameter of the coil; assuming that you are going to use the usual formers of 3in. diameter, we suggest from 65 to 70 turns of No. 26 D.C.C. solid wire.

○○○○

Overrunning a Valve.

As I should like to obtain a greater undistorted output from my last valve (a D.E.5a) I am thinking of increasing the H.T. voltage from 120 to 160. Is it necessary to observe any special precautions?

G. L.

In the first place we ought to tell you the proposed voltage is above the maximum specified by the manufacturers, and consequently you should pay attention to several points. The grid circuit must never be broken while the filament is glowing; in other words, the valve should not be operated without a very considerable negative voltage (amounting to at least 30 volts) on its grid. Furthermore, we recommend you to run the filament at the full 6 volts provided by the L.T. battery, and not at the slightly lower voltage customarily recommended for this type of valve.

○○○○

Short-circuited Grid Bias.

The tuning condensers of my four-valve set (one H.F. stage) are fitted with circular metallic discs for screening purposes. At present they are left unconnected, as they were not shown in the design which I followed. Would it be desirable to connect them to earth?

A. J. B.

It is quite possible that you would obtain greater freedom from hand-capacity effects by earthing the shields, but before doing so you should assure yourself that the extra connection will not have the effect of short-circuiting any grid bias batteries which may be used for the H.F. and detector valves.

Consideration of the circuit diagram of a typical receiver will show you that a short-circuit of this kind will be introduced if the discs happen to be in metallic connection with the condenser vanes.

The Wireless World

AND
RADIO REVIEW
(16th Year of Publication)

No. 465.

WEDNESDAY, JULY 25TH, 1928.

VOL. XXIII, No. 4.

Editor: HUGH S. POCOCK.
 Assistant Editor: F. H. HAYNES.
 Editorial Offices: 116-117, FLEET STREET, LONDON, E.C. 4.
 Editorial Telephone: City 9472 (5 lines).
 Advertising and Publishing Offices:
 DORSET HOUSE, TUDOR STREET, LONDON, E.C. 4.
 Telephone: City 2847 (13 lines). Telegrams: "Ethaworld, Fleet, London."
 COVENTRY Hertford Street.
 Telegrams: "Cyclist, Coventry." Telephone: 5210 Coventry.
 BIRMINGHAM: Guildhall Buildings, Navigation Street.
 Telegrams: "Autopress, Birmingham." Telephone: 1970 and 2971 Midland.
 MANCHESTER: 260, Deansgate.
 Telegrams: "Hiffe, Manchester." Telephone: 8970 City (4 lines).
 Subscription Rates: Home, 17s. 4d.; Canada, 17s. 4d.;
 other countries abroad, 19s. 6d. per annum.
As many of the circuits and apparatus described in these pages are covered by patents, readers are advised, before making use of them, to satisfy themselves that they would not be infringing patents.

CONTENTS OF THIS ISSUE.

	PAGE
EDITORIAL VIEWS	89
COMPROMISE IN RECEIVER DESIGN: PART I	91
VALVES WE HAVE TESTED: MULLARD P.M. 4D.	96
D.C.S (CONCLUDED). BY A. L. M. SOWERBY	97
TESTING A STANDARD FOUR	103
PROGRAMMES FROM ABROAD	105
CURRENT TOPICS	109
USEFUL DATA CHARTS: NO. 3	110
NEW APPARATUS	112
THE OUTPUT STAGE AND THE PENTODE: PART III. BY N. W. MCLACHLAN	113
BROADCAST BREVITIES	117
LETTERS TO THE EDITOR	119
READERS' PROBLEMS	120

PICTURE BROADCASTING SOON.

BEING such a fruitful field of remarkable achievement, wireless has long been the subject of exaggerated claims, so that each advancement must necessarily be viewed from an angle which will reveal its technical soundness. From this aspect one claim may be set aside, ignored, or adversely commented upon in the pages of this journal, while another is hailed as a mark of progress and its technicality described. This precautionary observation is, perhaps, not out of place when making the statement that picture broadcasting, as well as reaching the stage of successful demonstration in the hands of the experimenter, has recently been so perfected as to take its place as a parallel service to the broadcasting of speech and music.

Readers will remember the publication of articles describing in detail each of the picture transmitting systems of to-day, some particularly suited for newspaper work while others have been especially directed towards the perfecting of apparatus for home picture reception. Time has proved that of the many methods of picture sending which have been worked upon, that devised by

Mr. Thorne-Baker has ultimately been found most suitable as the basis for developing for wireless broadcasting. The perfected apparatus of to-day is fundamentally similar to his early apparatus, in that the image to be transmitted is carried on a cylinder, is traversed by means of a guide screw, and recording is produced by a chemical stain created by an electric current. Synchronising the transmitting and receiving gear so that the cylinders run in step within extremely small limits has been the problem from the start.

Simpler Synchronising.

It is for a satisfactory solution of this apparently simple problem that picture broadcasting has waited, and it is upon this question, also, though rendered many thousand times more difficult, that the achievement of television depends. Pendulums, valve oscillators, phonic motors, and astronomical clocks have all been tried, giving success in many instances though suffering from the serious defects of complication and difficulty of operation. The apparatus which has now been evolved does not suffer from these difficulties and solves the problem of the subsidiary synchronising apparatus in a simple manner—it has none.

It is due to Capt. Otto Fulton that the necessary refinements of design have resulted. His system, briefly, is the screw traverse cylinder rotated by clockwork, and the electrolytic image as used by Thorne-Baker, to which have been added a magnetic clutch with lock, cams, and switching contacts. Just as a sewing machine depends for its performance upon perfection of detailed design and refinements in workmanship, so has Capt. Fulton's apparatus succeeded where earlier instruments were defective. Transmitting and receiving cylinders are held in step by a wave train transmitted once each revolution which, through the switching contacts and cams and a very simple little relay adjusts the position of the cylinder at the receiver, so that it runs relatively with that at the transmitter. A moment's thought discloses that the cylinder on which the picture is to be received is both started and stopped by the signals of the transmitting station, and to see the apparatus in operation, working in an untailing fashion on a comparatively weak signal, is fascinating. Experimental readers realising the difficulties involved, may view successful relay actuation with diffidence, yet a controlled current of 3 mA. is readily delivered by a rectifying valve connected to the output terminals of a receiving set, and relays of modest resistance are available which will work on this current. The actual relay used is little bigger than the magnetic system of a loud speaker, and that it is robust is revealed by the fact that it is housed behind

the metal panel of the set without access for adjustment. Picture broadcasting experiments are already being conducted by the courtesy of several of the European

the high-power station of the Wolfe Bureau, Berlin, for reception in London. It is presumed that transmissions will be conducted in this country without much delay.

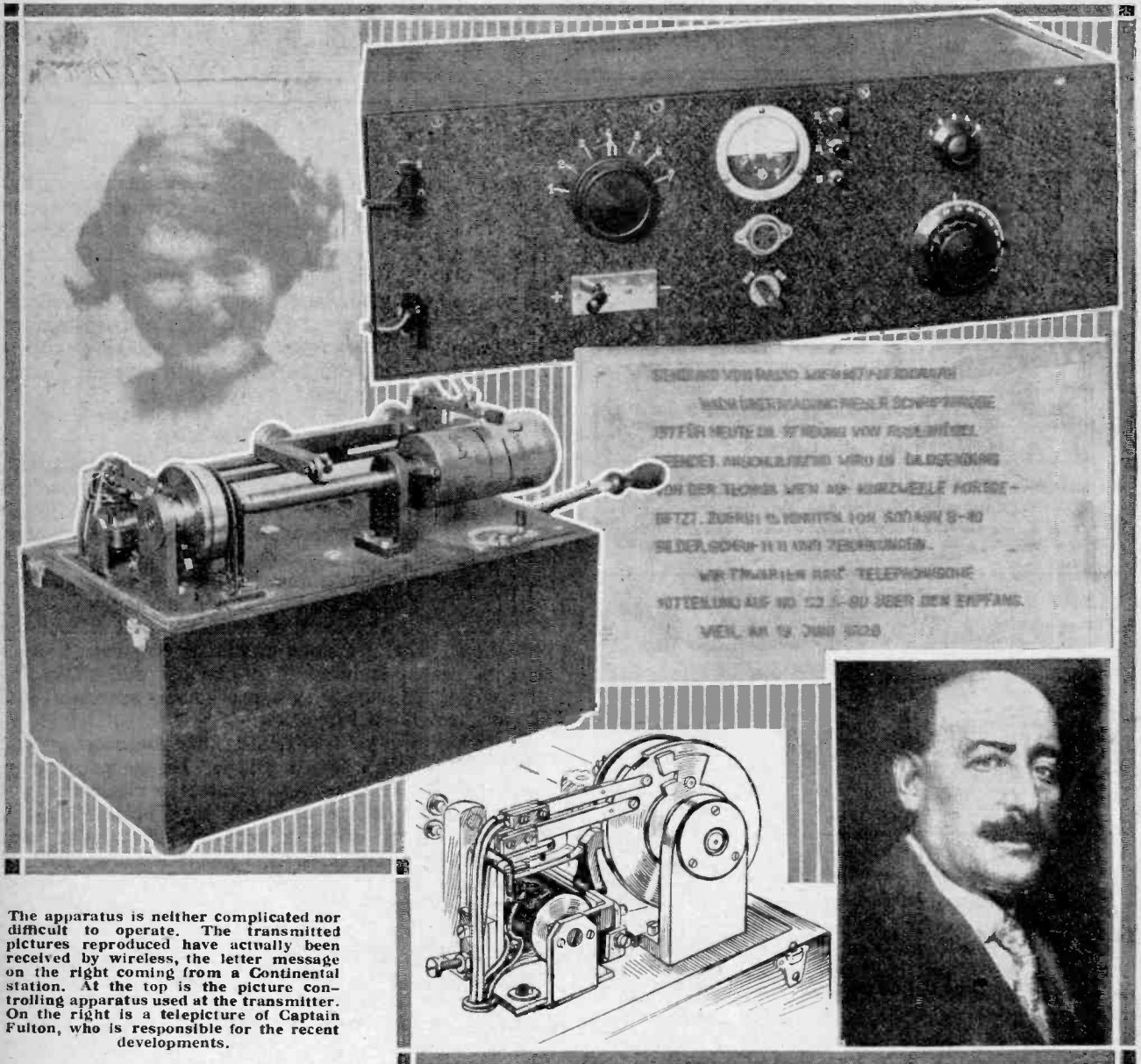

The apparatus is neither complicated nor difficult to operate. The transmitted pictures reproduced have actually been received by wireless, the letter message on the right coming from a Continental station. At the top is the picture controlling apparatus used at the transmitter. On the right is a telepicture of Captain Fulton, who is responsible for the recent developments.

broadcasting stations. Transmissions first commenced last November from the Budapest station, Czepel (555.5 metres). Later transmissions from the Rosenhügel station at Vienna were successfully received at Budapest. Berlin (Witzleben, 483.9 on 4 kW.), Geneva (760 m.), and Radio Paris (1,765 m.) have also undertaken transmissions giving good reception up to the reasonable limits of long-distance broadcasting. Short-wave tests, although of no great interest, have been carried out between Vienna (EATH, well known to short-wave enthusiasts) and London, while during the past week picture transmissions have been made from

either on a semi-experimental basis through our broadcasting stations, or from an experimental broadcasting station licensed to conduct picture transmissions. Now that an apparatus of proved performance is available, it is to be hoped that we shall not have long to wait before we can switch over from our loud speaker terminals to a simple machine which will start and stop by the control of the broadcasting station, and reveal to us an illustration of topical interest and from a distance, perhaps, beyond that which can be reached by illustrated daily newspapers. Herein the amateur and the listener have something new.



A New Technical Data Series on Set Design and Performance.

ONE of the commonest problems of wireless, and one which confronts every enthusiast at irregularly recurring intervals, is that expressed in the question "What set shall I build?" If the question refers only to the difficulty of making a choice among the various published designs, the task of finding an answer to it is comparatively simple, because there are only a few hundred different designs from which to select, and it should not be very difficult for each prospective builder to pick out the one which most nearly satisfies his aspirations.

But if the question implies that the receiver is to be designed, as well as built, by the seeker after inspiration, then the number of possible variations becomes almost infinite, and the difficulty of selection is really acute.

It would seem that the obvious way of setting about the design of a receiver for any given purpose would be to begin by setting down on paper the circuit of a perfect set and then, having evolved that, to simplify it down until its construction is neither so difficult nor so expensive as to place its practical realisation out of reach. If only it were possible to design the perfect receiver, this mode of procedure would be quite a good one, but if one attempts to design a set with no shortcomings whatever, even if constructional difficulty, complication, and expense are not regarded as serious barriers, it will be found that the task is quite impossible.

The reason for this will be appreciated by anyone who, like the writer, has often been asked by friends to act as designer for them, or to choose a set from among the many commercial models now available. Even with the enormous simplifications that are introduced into the task of designing by an exact knowledge of the conditions

under which a receiver is to be used, of the results that will be expected of it, and of the operating skill, the psychology, and the musical taste of the prospective users, it is found possible to produce nothing better than a compromise, in which every desirable quality is sacrificed, to some small extent at least, in the effort to retain a reasonable degree of excellence in some other respect. If, with all the advantages just enumerated to help in the design of a set that shall fulfil perfectly only certain limited requirements, only an approximate compromise can be attained, what hope is there of producing a set that shall be perfect in the abstract, and that shall be suitable for every user, and for every possible set of conditions?

Compromise is called for in receiver design when balancing the factors of cost, simplicity, range and quality. This article, the first of a series outlining the basis of receiver design, brings forward the many considerations involved when selecting the loud speaker and output amplifier.

A summary of accepted present day practice will be dealt with in the following instalments under this heading. Not only will the conflicting considerations be debated but definite guiding summaries will be outlined. Although popular in presentation, the ground to be covered omits none of the complex underlying principles involved. The aim had been to cater for the needs of the beginner and the set builder as well as the broadcast receiver user yet the store of technical data to be included will render these articles of infinite value even to the experienced experimenter.

Range, Simplicity and Cost.

In order to bring into prominence some of the little obstacles that beset the way of the too-optimistic designer, let us set down and discuss some of the qualities that a perfect set must possess.

It must be sensitive, selective, easy and cheap to build and use, and must give reproduction of irreproachable quality at considerable volume. It should, if possible, be run entirely from the public supply mains and not from batteries, and it should be as simple, and employ as few valves, as possible. In addition, many users would prefer, and a few would insist, that it should work with a frame aerial enclosed within its cabinet, or at most with a few feet of wire round

the picture rail. Distant transmitters, even those closest in wavelength to the local station, must be heard at full strength without interference from the latter, and it should be possible to receive transmissions on any wavelength, preferably without the need for changing coils.

The difficulty about this specification is that each of

Compromise in Receiver Design.—

the qualities we have taken as desirable cannot be attained in full measure save at the expense of other features that we would wish to retain. It must be sensitive, we have decided, and must bring in distant stations with only a small aerial; then it certainly cannot be either easy or cheap to build, and can only be made easy to handle at the expense of a very great deal of difficult extra work in the making. It will certainly not be simple, and it will employ many valves rather than few. Again, we have said that the perfect set must be selective enough to cut out the local station and receive distant stations on closely adjacent wavelengths; then once more simplicity, cheapness and ease of handling must be thrown overboard, for we shall require for this purpose a multiplicity of tuned circuits in cascade. Quality, too, will suffer to a very appreciable extent through the cutting of side-bands that is an almost inevitable corollary of high selectivity. And finally, as a third example of the difficulties that beset the designer, the stipulation that quality must be irreproachable implies that all attempts to obtain high amplification per stage, either on the high- or low-frequency side of the receiver, must be abandoned; and neither sensitivity nor selectivity can be high unless a very large number of valves are to be used. Cheapness, too, must be regarded as impossible where the highest quality, with adequate volume, is essential—unless, of course, we exclude the cost of the valves and the necessary installation for supplying the energy required by the set.

The reader who has not previously been brought into contact with the details of receiver design, but has been content to accept published designs without going into them very deeply, will now begin to see that every set that has ever been built must of necessity embody a whole series of compromises between conflicting claims.

What is Your Ideal Receiver?

One of the reasons for the multiplicity of designs is to be found in the fact that no two designers value alike the various features of a receiver. The present writer, for example, demands from any receiver that he uses a standard of quality, and a generosity of volume, considerably in excess of the requirements of most of his friends, and is willing to sacrifice sensitivity to attain these qualities, which are to him very much more important. If asked to design a receiver, and restricted to the use of three valves, he would probably produce an instrument which would give first-class results on the local station but would be quite incapable of receiving any other programmes whatever. Another designer, who might not be willing to go to such lengths in the interests of quality and volume, would design for higher

amplification per stage, and so would have sensitivity enough in hand, with his three valves, to enable him to produce a machine that would receive, at least on telephones, a large number of distant stations. Which of these two would be accounted the better receiver would depend entirely on the personal taste of the user; there is not, nor can there be, any absolute standard in these matters.

An Analysis of Detail.

The complexity of receiver design, and the need of compromise at nearly every stage from the aerial to the loud speaker, will by now be evident; it may be of assistance to those who are choosing a set, or thinking of designing one, to go a little more fully into the various parts of the complete receiver, in order to show in some detail the way in which the various factors are balanced against one another.

It is proposed to take the various sections of the receiver in a rather peculiar order, beginning with the output stage, following this with a consideration of the detector and the low-frequency amplifier, and putting the high-frequency amplifier last. This order, eccentric as it may appear, is in the writer's opinion the easiest to use in working out the details of design.

It is necessary, first of all, to determine the output required from the receiver, as this fixes the type of valve required in the last stage and also, in all probability,

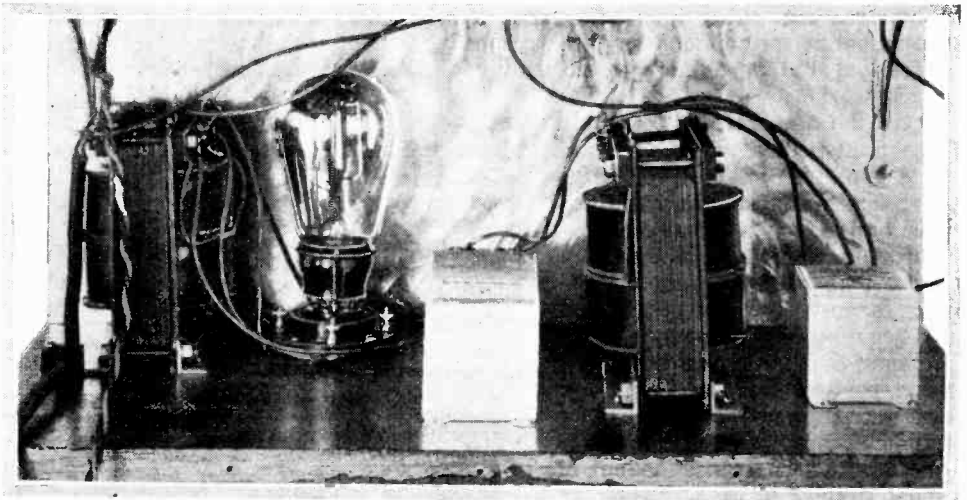

Small A.C. rectifier suitable for use with a receiver operating a loud speaker of the horn type.

the high-tension voltage that will have to be used at that point. It will not normally be economical to employ a higher anode voltage than this on any earlier valve, so that all other stages must be designed with this anode voltage as the highest available. To simplify connections, the same voltage should be used throughout if it can be made possible to do so.

The detector is the next consideration, because the whole design of the amplifiers, whether for high- or low-frequencies, will depend on whether our choice falls on an anode bend or a leaky grid rectifier. Having made this choice, the design of the low-frequency amplifier necessary to magnify up the output of the rectifier

Compromise in Receiver Design.—

chosen so that it will operate the output stage that we have decided upon can then be undertaken. This done, it only remains to consider the aerial arrangements to be used, and the number of stations required, in order to decide upon the amount of amplification at high frequency necessary to feed the detector with the signal voltages that it requires. In doing this the aerial size and the high-frequency amplifier must be balanced

against one another in such a way as to provide the selectivity that the local conditions make necessary, keeping in mind the possible addition of a loose-coupler as a kind of fine adjustment in this process.

Complicated as all this may appear, the writer has found less need for revising decisions already made when designing a receiver in this order than when going through it straightforwardly from aerial to loud speaker, or from loud speaker to aerial.

THE OUTPUT STAGE.

Although there is no need for compromise, in the sense in which we have been considering it, in the output stage alone, it is so vital a part of the receiver that no discussion of receiver design would be complete without some mention of it. In addition, the output stage is the controlling factor, if not in the cost of the set itself, at least in the cost of the equipment as a whole; so that there is real need in many cases for a compromise between the ideal that we should like and the attainable which we can afford. In this connection, some idea of the relative costs of various types of output stages will be given.

[Horn Loud Speaker and Modest Output.

The power-handling capacity of the last valve, and the high-tension voltage required, are to a large extent determined by the type of loud speaker to be used. If this is of the horn type, it will not be of any advantage to try to obtain loud signals, on account of the lack of bass notes in such models. If a band or orchestra is heard in the open air, and the listener retreats slowly from the neighbourhood of the performers, it will be found that as the sound grows fainter the prominence of the lower tones will diminish, until at a considerable distance, when the music as a whole is heard only faintly, the bass will appear to have vanished altogether. If we work a loud speaker which does not reproduce the bass notes at a volume such that the music is quite faint, the lack of bass will not be very noticeable, for the sounds that reach the ear will correspond reasonably closely with those that are heard on listening to a real orchestra at a considerable distance. But if the same loud speaker is fed with considerably more power, it will be found that its reproduction sounds intolerably false, for we shall be listening to a volume that corresponds in overall magnitude with an orchestra at fairly close range, but from which the bass notes that we are accustomed to hear under such circumstances are entirely missing. The writer is of opinion that where a horn type of speaker is in use no advantage is to be gained by employing a larger output than can be obtained from a "power" valve of some 7,000 ohms impedance with a plate voltage of about 140 volts, or a "super-power" valve of some 3,000 ohms impedance with about 90 volts.

Where a cone type of speaker is to be worked, larger outputs can usefully be employed. It is difficult here to make any really definite suggestion, as there are such very wide variations, both in ability to reproduce bass notes and in sensitivity, between loud speakers of this class. The writer has in mind two in particular, which

represent roughly the extremes between which the bulk of such instruments lie. One of these is very highly sensitive, and reproduces the bass notes decidedly poorly; it is very adequately served by a single "super-power" valve run at the maximum voltage that the makers recommend. A greater input than this, owing to the sensitivity and the lack of bass notes, does not give the best impression on the listener of which the speaker is capable—it lies, in fact, in its general characteristics, very close to the best of the horn loud speakers. At the other end of the scale is an instrument which is very insensitive, but which is capable of giving a reproduction of bass notes that is only noticeably inadequate when comparison is made with a moving-coil speaker. The insensitiveness of the instrument means that a good deal of power is required to operate it loudly, and in addition to this its bass response implies that it can deliver a large volume of sound before its imperfections become obtrusive. These two factors, working together, make it possible to feed this particular speaker with the output from at least two "super-power" valves, with a plate voltage of 200 volts or over. Even with the large volume that such a supply of power can produce, the music remains satisfactorily realistic, and can be made to correspond closely enough to deceive the ear with what is heard when sitting in the back seats of a concert hall. There are cone speakers of all intermediate types between these two extremes.

Moving-coil Comment.

If we wish to sit in the stalls, however, there is no speaker possible save the moving-coil type, but it must not be forgotten that one cannot sit in the stalls for the price of a gallery ticket; this type of speaker is not cheap to install or use, though most people who have not gone into the matter have an exaggerated idea of its cost. A moving-coil speaker can very satisfactorily be worked at such a volume that it is quite impossible to carry on a conversation through the music, and, even at this strength, there need be no falsity that the ear can detect without direct comparison with a real orchestra. A volume of sound such as this can be obtained, if it is wanted, with two LS5a-type valves, using a plate voltage of about 350 volts.

It must not for a moment be thought that the moving-coil speaker will not perform satisfactorily on a far less ambitious equipment than the one that has just been suggested, for two "super-power" valves, with about 160 volts on their plates, will make a very pleasing noise indeed. The figures given in discussing the other types of speaker were intended to indicate not the minimum

Compromise in Receiver Design.—

power that could be used to operate them, but the maximum above which their defects become unduly prominent, while in the case of the moving-coil speaker the LS5a equipment indicates a maximum too, but a maximum beyond which the volume of sound produced becomes utterly intolerable in any room smaller than a concert-hall.

While on the subject of the power required to operate satisfactorily a moving-coil speaker, there is one common misconception that it is a pleasure to contradict. It is widely believed that this speaker is extremely insensitive, and that it will only work properly with a high-power equipment. The real truth of the matter is that it is not nearly so insensitive as many of the cone-type speakers working on the reed or balanced armature principle, and that the replacement of one of these by a moving-coil instrument will in very many cases result in an unexpected and very considerable increase in signal strength as well as the improvement in quality that one would naturally anticipate. The fact that this speaker will stand an input that would show up with merciless clearness the shortcomings of other instruments appears to have led to the general acceptance of the myth that such an input is essential for proper working, whereas in fact it is only necessary where it is desired to reproduce music at or near its original level of loudness.

In the case of the output stage the necessity for com-

working voltage. Thus if 350 volts are used on the output valves, there will be some eight or nine hundred volts across the extremities of the centre-tapped secondary. Those who are not at home in handling high voltages might be well advised to refrain from using an installation of this magnitude, while in any case precaution is needed to prevent accidents to uninstructed members of the household.

Running Cost of the Moving-Coil Loud Speaker.

Reverting to the question of cost, it may be of interest to those who are considering the possibility of a moving-coil speaker to learn that an entire equipment for A.C. mains, using LS5a valves at their maximum useful voltage, can be obtained for about £25. The outfit includes the speaker itself, a first-class commercial battery eliminator giving 350 volts, a battery-charger for feeding the field-winding of the speaker and small accumulators for smoothing the output of the charger, a pair of LS5a or B12 valves, and a small transformer for lighting their filaments so that their heavy filament current shall not be drawn from the usual L.T. battery, but can be taken from the mains. It is intended here that everything, save the speaker itself, should be bought complete as a finished commercial article, but if it is decided to undertake the assembly and construction of a larger proportion of the apparatus, the cost can be reduced by some five or six pounds.

The consumption of the whole will run into about 180 watts, or about three times the consumption of the ordinary electric lamp; say about a penny per hour. The battery eliminator will, in addition, supply high-tension current for the rest of the set without any appreciable increase in the consumption of current, so that this figure represents the entire cost of maintenance other than that of the filament accumulator for the earlier valves of the set.

It will at once be noticed that although the initial cost of a powerful installation such as this is high, once the plunge has been taken and the equipment purchased,

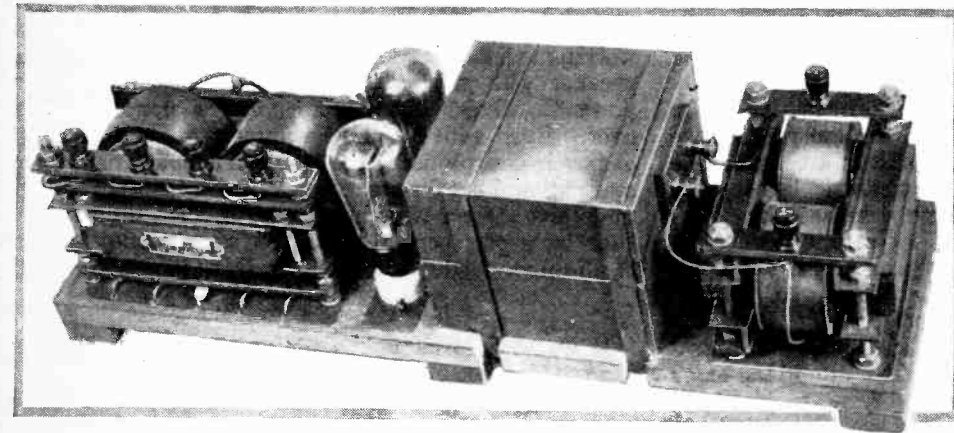

When the best quality of reproduction is desired the use of a liberal output stage fed with a high potential anode current becomes essential. A high voltage A.C. rectifier recently described. Filament current for the output valves is provided by one of the transformer windings.

promise arises largely on account of the cost of the installation necessary to run a moving-coil speaker at full power, and, to a limited extent, on account of the fact that the higher voltages used are definitely dangerous. Taking the second point first, the writer would suggest that plate potentials higher than about 200 volts should not be employed unless all danger of shocks is carefully guarded against, or unless all persons likely to come into contact with the apparatus are warned that serious harm may result from meddling with the interior of the apparatus while the power is switched on. This danger is especially great where rectified A.C. is used, as a transformer supplying a full-wave rectifier delivers an overall voltage which is some two-and-a-half times as great as the

the running costs are about the same as the usual expenditure on the dry batteries or accumulators necessary to work quite a modest set, and there is, of course, complete freedom from the many troubles that run-down batteries bring in their train.

If a less ambitious output stage is required, a moving-coil or good commercial cone speaker, fed by two "super-power" valves with about 160 volts H.T., will perhaps be looked upon with favour. This is, as a matter of fact, almost exactly the equipment that the average listener requires to provide entertainment of first-class quality, and moderate but pleasant strength, suitable for the ordinary living-room.

The cost of an outfit of this type is not very easy

Compromise in Receiver Design.—

to specify exactly, because there are speakers of many types at varying prices, in addition to the moving-coil type; and further, the high-tension current may be taken from either A.C. or D.C. mains, or from H.T. accumulators, so that there are wide variations both in first cost and in upkeep.

Comparative Running Costs.

Approximate figures are, therefore, given in the accompanying table, in which first cost and running expenses in pence per hour are given for each separate item of the outfit. Any who are interested can add up the cost of the various items that make up the equipment that they have in mind, and so arrive at the total cost that applies to the particular installation to which their taste inclines.

	First Cost.	Running Cost. (Pence per hour).
Cone-type speaker. (Commercial pattern)	£5 upwards	Nil.
Moving-coil speaker	£4 10 0	See "Field Supply."
Field Supply for m.-c. speaker.		
(a) From A.C. mains	£4 15 0	0.30
(b) From D.C. mains	Nil.	0.12
(c) From accumulators (6-v. 1 amp.)	£2 0 0	0.56
H.T. Supply.		
(a) From A.C. mains	7 0 0	0.10
(b) From D.C. mains	£4 0 0	0.03
(c) From accumulators	£6 0 0	1.18
Two "Super-power" valves	£2 0 0	—
Two (a) From A.C. mains	£3 0 0	0.03
(b) From accumulators (6-v. 1 amp. each)	£3 0 0	0.33

Several assumptions have been made in working out the figures given, and it is felt that it is desirable to make them clear. It is presumed that the moving-coil speaker will be assembled by the user from parts bought ready machined, so that all that has to be done at home is the making and fitting of the paper cone. The cost of electrical energy from the mains is taken as 5d. per unit of one kilowatt-hour, which is thought to be a fair average among the many different rates in use. For other rates the necessary correction can easily be applied. No depreciation costs are allowed for except in the case of accumulators, for which a life of three years at full efficiency is assumed. In practice, they will probably last longer, but this extra life will be made up for to a great extent by the fact that decreased efficiency will result, as they grow older, in a shorter period of service from each charge. It is further assumed that the accumulators will be charged by a garage or wireless dealer, and the cost of each charge is reckoned on the basis of the rates in vogue in London. In estimating the expenses incurred in connection with the installing and running of the output valves themselves, half the cost of the filament accumulator is included in the first cost, and half the depreciation in the running costs. The remainder, both of first cost and depreciation, may fairly be charged to the rest of the set, with which we are not here concerned.

It is possible to sum up the first cost and running

costs of three typical installations on the lines suggested, using a moving-coil speaker; where a commercial speaker is used, variations in price make the first cost a matter depending very much on personal choice. The figures for the three installations are as follows:—

	First Cost.	Upkeep. Pence per hour.
A.C. Equipment	£19 5 0	0.43
D.C. Equipment (with accumulator for filaments of valves)	£11 5 0	0.48
Battery Equipment	£15 5 0	2.07

The very high cost entailed in running a big receiver from accumulators is very striking, and provides, perhaps, the strongest possible argument for using electric mains if they are available. The use of dry batteries is not considered, as the running costs would then rise to a prohibitive figure.

The Popular Need.

The figures for the particular output stage that we have just been discussing have been gone into at some length because the writer feels that an installation of about this power is exactly what is required to give music of really high quality at a strength suited to an ordinary drawing-room, and is therefore that which, in time, every listener will wish to acquire. A larger output of sound is not necessary except in a very large room indeed, while a smaller output fails to give any impression of reality.

If we drop to a smaller output, suitable for a horn speaker or a sensitive example of the cone type, using a single "super-power" valve with not more than 120 volts on its plate, we arrive at the following figures for installation and running:—

	First Cost.	Upkeep. Pence per hour.
A.C. Equipment	£10 10 0	0.1
D.C. Equipment	£7 0 0	0.11
Accumulator Equipment	£9 0 0	0.45

In obtaining these figures an outlay of £3 on the speaker is assumed.

From these three main classes the listener must choose, trying to select an equipment that will satisfy his musical taste without making too big a hole in his pocket. He must, further, take into consideration, if electric mains are available, whether he will make the extra outlay on smoothing, and, if necessary, rectifying, apparatus to enable him to use them, or whether, for the sake of the lower first cost, he will accept the greater liability to trouble and the higher running cost involved in continuing to use the battery supply that, in all probability, he already possesses.

The choice must not be made hastily, for upon it will depend not only the design of the rest of the receiver, but the degree of pleasure that his outfit as a whole will give him.

NEXT WEEK: When it is better to use a crystal—Leaky Grid v. Anode Bend Detection.

If you are in doubt as to the precise constructional details of a receiver described in the pages of this journal then call at 116, Fleet Street, London, E.C.4, and examine the actual set.

Now on view—the New All-wave Four, the Switch-over Three and the D.C.5, together with the Mains Unit.

VALVES WE HAVE TESTED



MULLARD P.M.4.D.

Anode Bend Detection.

REGARDED from whatever standpoint this is an exceptionally good valve. The mutual conductance under amplifying conditions is 1.85, a figure hitherto associated only with indirectly-heated cathode receiving valves. It could be used as an output valve for moderate loud speaker volume, but would be more usefully employed as a first-stage L.F. amplifier or H.F. valve. In the latter position a coupling transformer with few turns on the primary would have to be used having regard to the low A.C. resistance of the valve. The following table shows the correct grid bias for amplification:—

H.T.	Grid Bias.	Anode current (mA).
80	-1½	3.7
100	-3	3.7
120	-4½	4.0

Useful as the P.M.4D. is as an amplifier it is of even greater value as a detector, and in particular as an anode bend detector followed by transformer coupling. Even for small inputs when the grid swing is confined to the bottom bend of the characteristic curve, the A.C. resistance is not more than 50,000 ohms, which is not really excessive if followed by a good modern L.F. transformer. In point of fact, the valve has been designed to precede the P.M. low-frequency transformer recently described in this journal.

The valve can also be used with success as a leaky grid detector, and it will be observed that the base of the grid curve characteristic is sharply curved. There is no reverse grid current up to -2 volts showing the valve to be hard.

The filament consumption is remark-

Transformer Coupling.

ably low having regard to the excellent characteristics, and in the particular valve tested was below the makers' rating. The makers deprecate the use of 6-volt accumulators, but it is probable that the majority of those who purchase this valve will be so equipped. Where a 6-volt supply is used for the filament current to other valves in the set, a 20-ohm resistance in series with the P.M.4D. filament is essential.

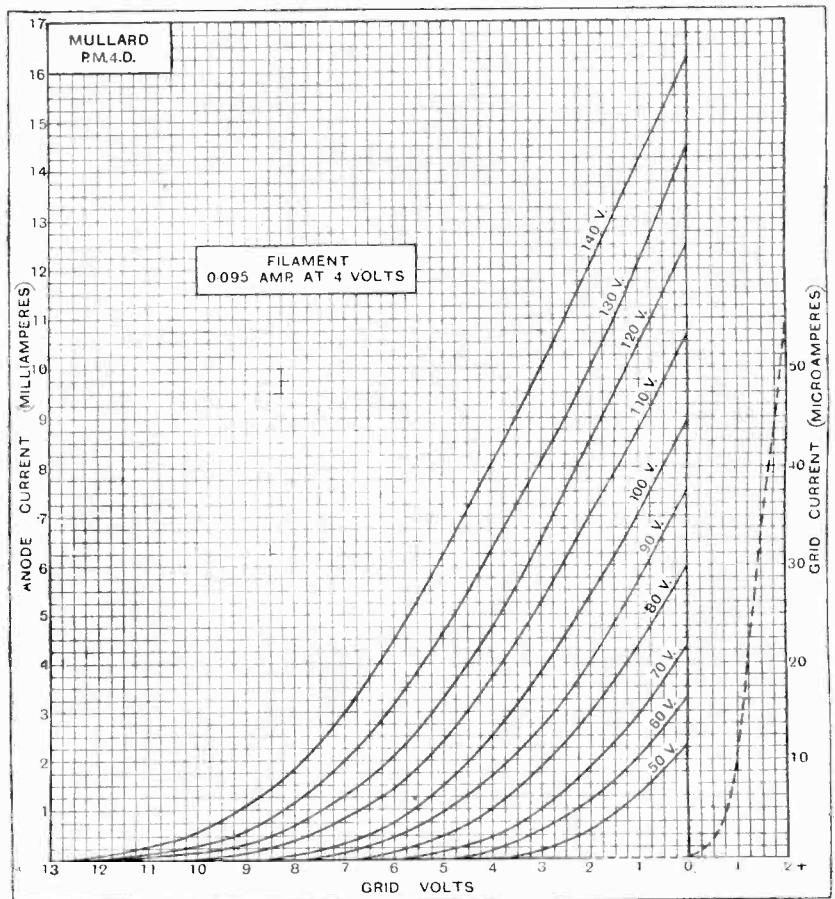

Average values for amplification—A.C. resistance = 6,500 ohms.
 Amplification factor = 12.0.
 Mutual conductance = 1.85 mA/volt

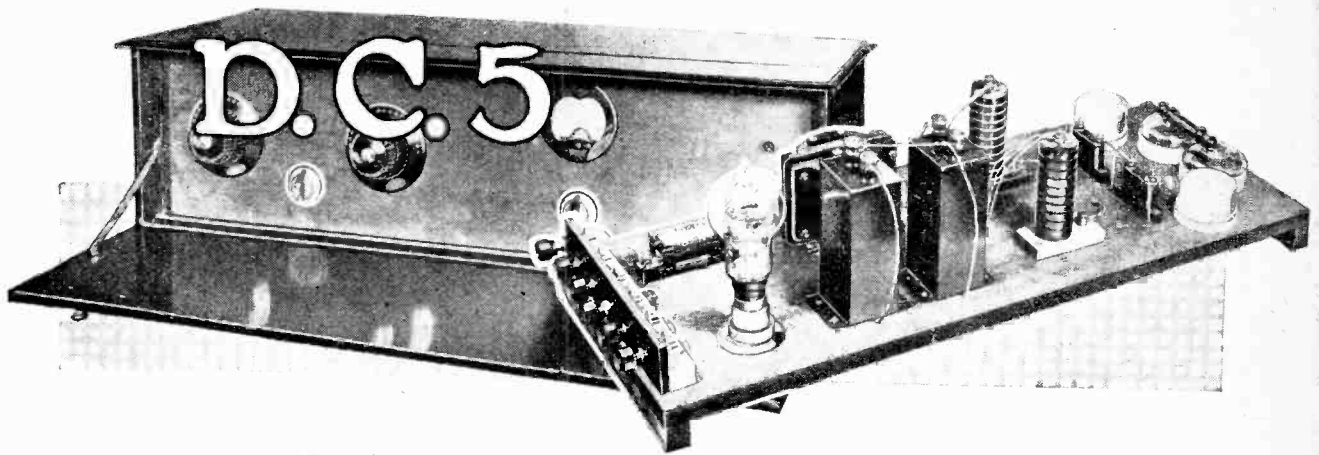

Constructional Details and Operating Notes.

By A. L. M. SOWERBY, M.Sc.

(Continued from page 64 of the previous issue)

THE schematic diagrams given in the previous instalment of this article have taken tangible form in the receiver of which the full theoretical and wiring diagrams accompany the present part. As will be seen, the installation has been built in two parts, one of which comprises the receiver, and the other the smoothing circuits. This is done in order to minimise the danger of hum, which might easily arise if receiver and smoothing circuits were built into one compact instrument. This separation into two parts undoubtedly adds to the total space occupied, and fails to make use of the opportunity afforded to get rid of the perpetual nuisance of battery leads or their equivalent. On the other hand, the incorporation of the smoothing circuits into the set would mean that unsmoothed current would necessarily be flowing in perilously close juxtaposition to grid circuits and other danger spots, so that elaborate screening of wires and components would be required. Even then, owing to the very different idiosyncrasies of

individual mains systems, the precautions might not be adequate. So, on balance, it was deemed wisest to build the eliminator separately from the rest of the receiver.

Stray Couplings Avoided.

The eliminator unit, designed specially for this receiver, is of the simplest. The theoretical circuit on which it is based is shown in Fig. 3, and has already been given in Fig. 2, with the exception of the series resistance in the high-tension supply to the third valve. This is primarily intended to restrict the voltage supplied to this valve, which has in its plate circuit only the primary of a transformer, to a value low enough to ensure a good life for the valve. Since this valve has only to deal with a signal input of the order of one volt, there is no particular point in running it with a greater plate voltage than suffices to enable it to be given a minimum grid-bias of about $1\frac{1}{2}$ volts. The

following values for this resistance will be found suitable for mains of various voltages:—

Mains voltage	Series resistance (ohms).
200	10,000
210 to 225	20,000
225 to 250	30,000

In addition, this resistance, with its associated condenser C_{11} (Fig. 6), acts as a resistance-capacity filter to check "motor-boating."

Similar filters are used in the plate circuits of V_1 and V_2 ; these, as their primary purpose is not that of controlling the working plate voltage, are incorporated in the set itself and not in the eliminator unit. The introduction of these filters, although in a sense an extravagance, has rendered possible an economy in

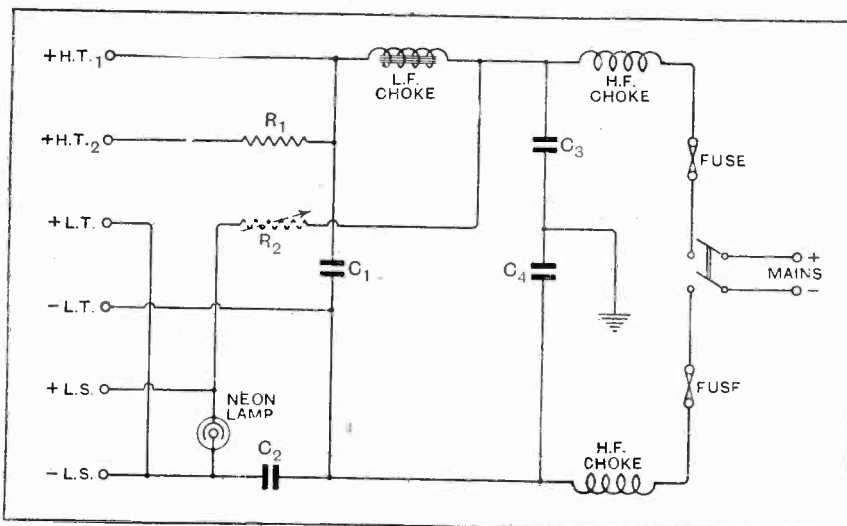

Fig. 3.—Complete theoretical diagram of eliminator unit. $C_1, C_2 = 4$ mfd.; $C_3, C_4 = 0.01$ mfd.

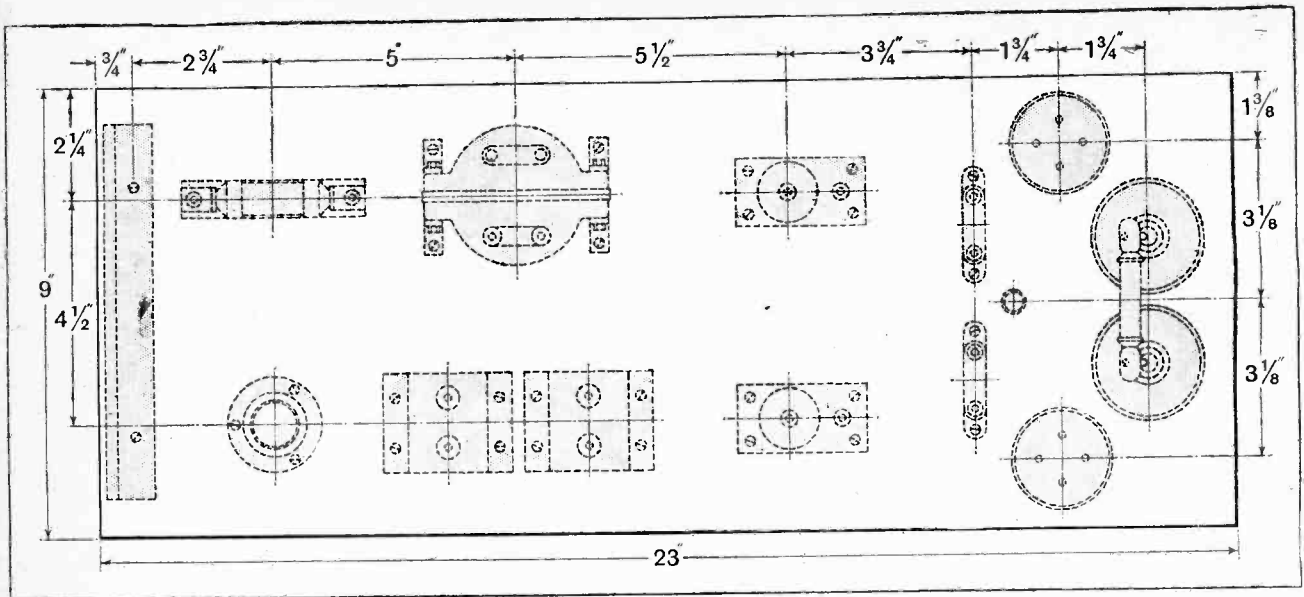

Fig. 4.—Dimensioned layout of parts on the eliminator baseboard.

smoothing chokes and condensers. For the entire H.T. supply to the set, one single choke and one condenser have been found sufficient. In the absence of these precautions against instability, it would have been necessary to use at least two entirely separate smoothing systems in order to eliminate coupling between the various stages, and to ensure freedom from "motor-boating" and kindred troubles.

From the point of view of smoothing, too, the single Marconiphone "Power" choke, in combination with a 4 mfd. condenser, is found to be adequate. Tests were made with a second choke, and a second 4 mfd. condenser in series with the first, making a two-stage filter, but the improvement in performance that resulted from the addition was so very slight that it was felt that

the extra expense of these additional components was not justified. The second 4 mfd. condenser on the eliminator unit is shunted across the filament supply terminals, and is not part of the high-tension smoothing scheme.

The choice of high-frequency chokes for the eliminator proved a difficult one, for these components have to carry a steady current slightly in excess of a tenth of an ampere, and even at this heavy current must not produce too great a drop in the voltage available for the high-tension supply. None of the commercial chokes with which the writer was acquainted could comply with these extremely exacting conditions, which is hardly surprising when it is remembered that a high-frequency choke usually has to carry only a few milli-

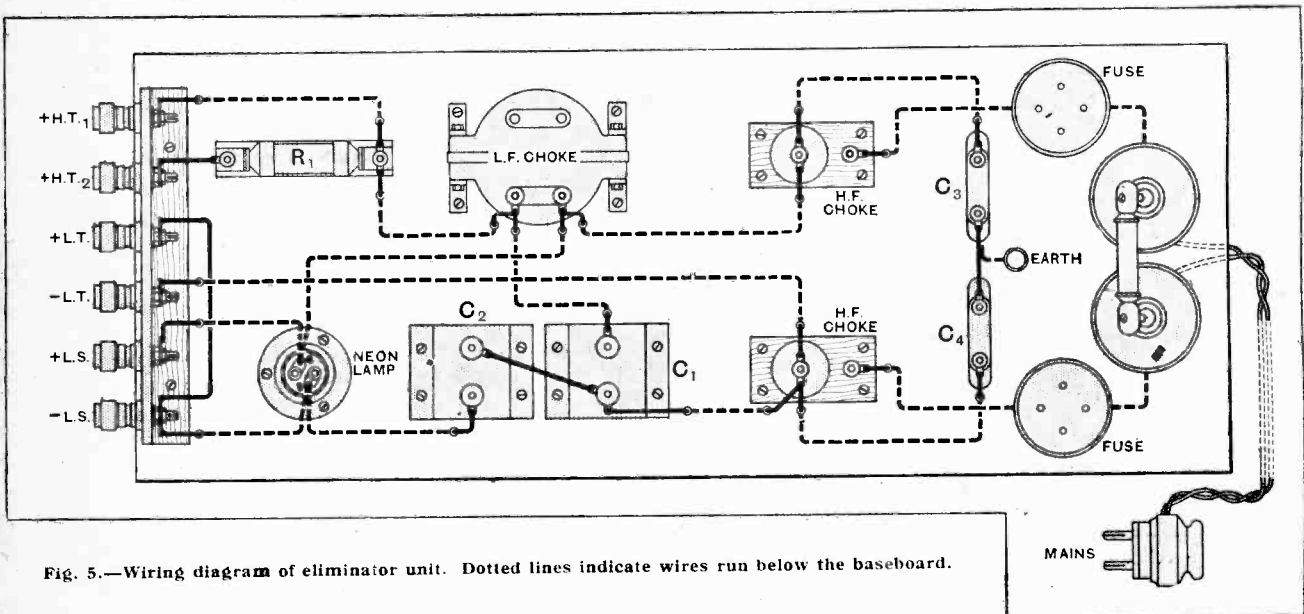
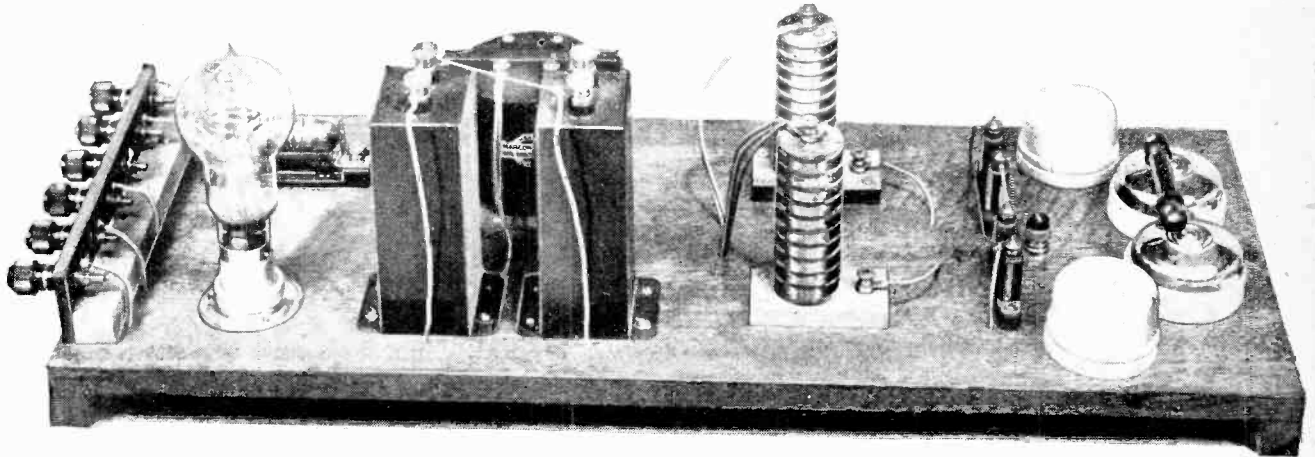

Fig. 5.—Wiring diagram of eliminator unit. Dotted lines indicate wires run below the baseboard.

D.C. 5.—

amperes. The chokes used, and shown in the photograph, are advance models of a special heavy-duty choke designed for this set and for similar installations by Messrs. Wright and Weaire. They are wound with comparatively heavy-gauge enamelled wire on a wooden former, and are, as would be expected, considerably larger and more robust than chokes intended to carry

been introduced between the mains and the H.F. chokes. When the switch is in the " off " position, the whole apparatus is completely dead, being entirely isolated from the mains. It is therefore impossible for the user to receive a shock with the switch off, no matter which of his mains is earthed. Similarly, the presence of a fuse in each lead acts as a complete safeguard against fire or other damage that might be caused



General view of the eliminator unit, showing low resistance H.F. chokes.

anode currents only. Their resistance amounts to some 50 ohms, so that little more than 5 volts is dropped across each of them even when carrying the whole current consumed by the receiver.

The only remaining point in connection with the eliminator unit that is worthy of special mention is in connection with the general problem of ensuring safety when the receiver is connected to the mains. With this aim in view, a double switch and two fuses have

by the earth connection being inadvertently allowed to come into contact with a part of the receiver from which it is supposed to be completely isolated. It is recommended that the finest tin fuse wire obtainable should be used, so that in the event of a short circuit the other fuses in the house may, if possible, remain intact.

Coming to the purely constructional side of the set, it is suggested that the drilling of the panel and the fitting of the components that it bears should be the

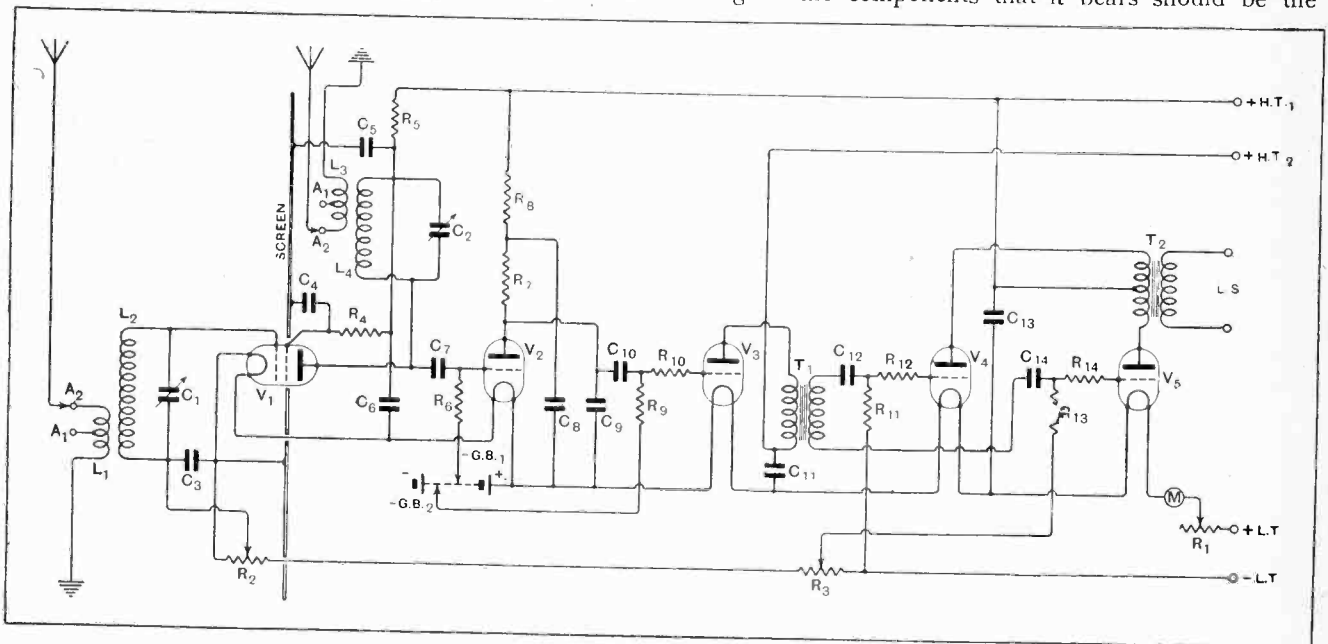

Fig. 6.—Complete theoretical circuit of receiver. $C_1, C_2 = 0.00035$ mfd.; $C_3, C_4, C_5 = 0.1$ mfd.; $C_6, C_7 = 0.0003$ mfd.; $C_8 = 0.0001$ mfd.; $C_{10}, C_{12}, C_{14} = 0.005$ mfd. $R_1 = 400$ ohms; $R_2 = 50$ ohms; $R_3 = 50$ ohms; $R_4 = 2$ megohms; $R_5 = 50,000$ ohms; $R_6, R_7, R_{11}, R_{13} = 5$ megohms; $R_8 = 150,000$ ohms; $R_{10} = 80,000$ ohms.

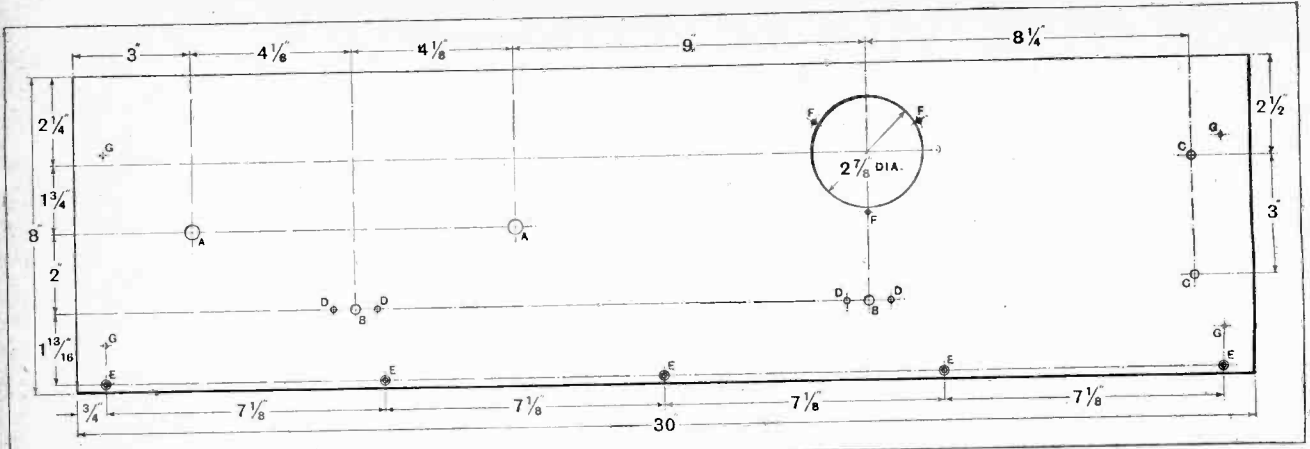

Fig. 7.—Drilling details of receiver panel. A, 3/8in. dia.; B, 1/4in. dia.; C, 7/32in. dia.; D, 5/32in. dia.; E, 1/8in. dia., counter-sunk for No. 4 wood screws; F, 1/8in. dia.; G, blind holes drilled and tapped 6B.A. behind panel.

first part of the work undertaken. This done, the components that are to go on the baseboard should be placed in position according to the diagrams given, and the panel should be propped up temporarily in the position it is to occupy when the receiver is finished. If components of other sizes and makes than those specified have been chosen, it will then be seen whether it is going to be necessary to vary the layout in any way to allow for differences in size or shape. It is considerably more satisfactory to make any such alterations at this stage before any components are screwed down and before any wiring is soldered in position.

Precautions in Wiring.

The advice to adhere strictly to the layout given for the high-frequency stage is no more and no less applicable to this receiver than to any other. In addition, as peculiar to this set, attention is once more drawn to the necessity for keeping the detector valve as far as possible from all other components save its grid condenser and leak, and for keeping down the length of the leads from these to the grid of the valve to the very lowest limit possible. If these precautions are neglected, hum, which is extraordinarily difficult to elimi-

nate completely in a receiver of this type, will be more in evidence than it need be.

When any rearrangement that may be necessary has been made, the positions of the components should be marked on the baseboard, and the panel removed and set on one side. The components can now be fixed in their final positions, and the process of wiring-up begun. It is not sufficient, where filaments are in series, to connect them to the nearest convenient point on the filament circuits, but they must in all cases run to the points indicated on the diagrams.

The wires to the panel will, of course, be left until all the other connections have been made, in order that the panel need not be attached to the baseboard until the latest possible moment. By this means the work of wiring-up, at best rather a tedious job, can be done with the maximum of comfort.

Since the magnet winding of the loud speaker is so essential a part of this receiver, there will probably be some who would like to satisfy themselves by actual experiment that the winding really has the resistance attributed to it before trusting it as the sole protection between the mains and the filaments of some four guineas' worth of valves. Fortunately, this measure-

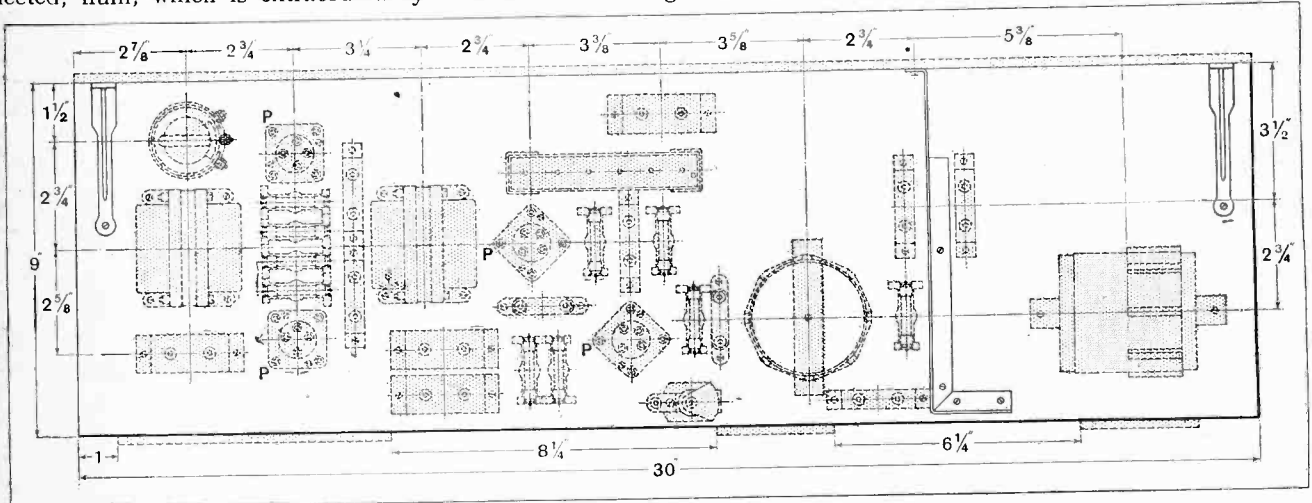

Fig. 8.—Dimensioned layout of receiver baseboard.

LIST OF PARTS (continued).—ELIMINATOR.

- | | |
|--|---|
| 1 Baseboard (23in. x 9in.). | 2 Fixed condensers, 0.01 mfd. (T.C.C.). |
| 1 Power choke (Marconiphone). | 1 Resistance, 10,000 ohms and holder (Ferranti). |
| 1 Lampholder (G.E.C.). | 1 Peerless resistor, 6 v., 0.25 amps. (Bedford Electric Co.). |
| 2 Cut-outs (G.E.C.). | 1 N.P. terminal (Belling Lee). |
| 1 Double-pole mains switch (G.E.C.). | 6 Ebonite shrouded terminals (Igranite). |
| 1 Wall plug. | 2 Special H.F. chokes, low resistance (Wright & Weaire). |
| 2 Fixed condensers, 4 mfd., 400 volt D.C. test (T.C.C.). | 1 Neon lamp. |

ment is easily made, within the wide limits of error that may be permitted, with the aid of the meter, which is part of the set. The meter should be temporarily connected in series with the loud speaker magnet and a 15-volt battery known to be in good condition; if the meter reads no more than 10 milliamps. the magnet has a resistance high enough for safety. If the reading is greater than this, a resistance of about 400 ohms, such as the winding of an ordinary potentiometer, should be connected in series with the magnet winding for the preliminary test.

The next step is to insert the valves into their sockets. Owing to the necessity for using valves which take a filament current of 0.1 amp., the choice in this direction

as to the current that they require, that the filament current passed when connected to an accumulator of the appropriate voltage should be measured with the aid of the meter in the receiver.

If it is found that the valve it is desired to use consumes only 0.075 amp. at its rated voltage, it may still be used provided that a small resistance is placed in the receiver in parallel with its filament to side-track the balance of the 0.1 ampere. By this means the valve is run at its correct current, while the full 0.1 amp. still passes through the filaments of the remaining valves and the magnet of the loud speaker. The resistance values required are 160 ohms for 4-volt valves and 240 ohms for 6-volt valves; they may be wound

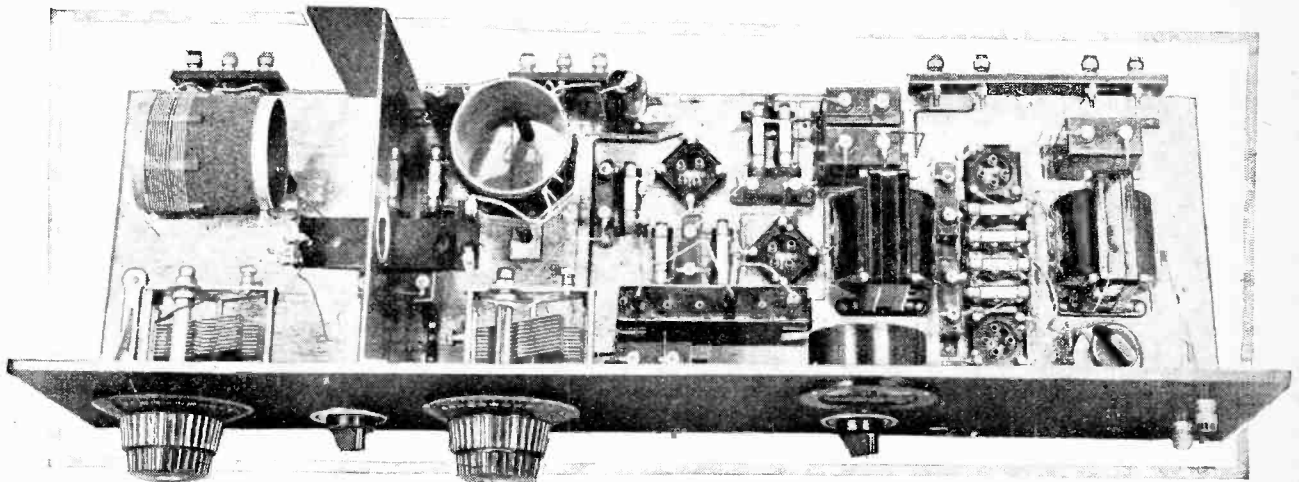

Plan view of receiver with valves removed.

is very strictly limited. Those for which the receiver was designed are as follows:—

H.F.	Cossor 210 screened valve.
Detector	Marconi-Osram D.E.H. 610.
L.F.	Marconi-Osram D.E.L. 610.
Output....	Cossor 610 P ("Stentor Six").

Other valves may be substituted for those recommended as detector and L.F. valves, provided that valves of closely similar characteristics are chosen. In selecting substitutes it must be borne in mind that either 2-, 4-, or 6-volt valves may be used, provided that the 0.1 amp. filament current is rigidly adhered to. It must be pointed out, too, that there are now on the market valves—notably the latest valves of the Mullard P.M. series—taking only 0.075 amp., and that if these are employed in the present receiver they will be overrun. If it is desired to use P.M. valves that are already to hand, it is suggested, if there is any possibility of doubt

of 38 gauge Eureka wire, the lengths needed to give these resistances being 6½ yards and 10 yards respectively.

So far as H.F. and output valves are concerned, the writer does not know of any alternatives to the Cossor valves already mentioned. In buying the output valves it will be well, if possible, to arrange to have a pair specially matched for use together in a push-pull stage.

When the valves are in position, the set can be connected up for its trial run. With the exception of the terminals marked "Loud speaker," it is only necessary to join together the pairs of similarly titled terminals on receiver and eliminator.

The flex from the eliminator may now be connected to the mains, and the switch turned to the "On" position. The variable resistance below the meter is turned until the arm just engages with the winding, the meter being watched the while. If the needle of the

D.C. 5.—

meter flies back below the zero mark, the current is flowing in the wrong direction, and the wall plug must be reversed in its socket. When this matter is rectified, the variable resistance is adjusted until the meter reads 90 or 100 milliamps.—no more, or the valves may be harmed. The filament current should not at any time be increased above the minimum value necessary to provide adequate signal strength on the nearest station, though this does not imply that this resistance should be used as a volume control.

other on the eliminator. In the other case the earth lead was left connected to the terminal on the set, but was disconnected from that on the eliminator, and joined through a condenser of 2 mfd. capacity to the "L.T. —" terminal.

Owing to the variations in the behaviour of different mains systems, it is suggested that the earthing in this way (through a condenser) of other points may be tried in cases where hum is obstinate.

In conclusion, the writer would like to draw attention to the exceptionally low running costs of this receiver,

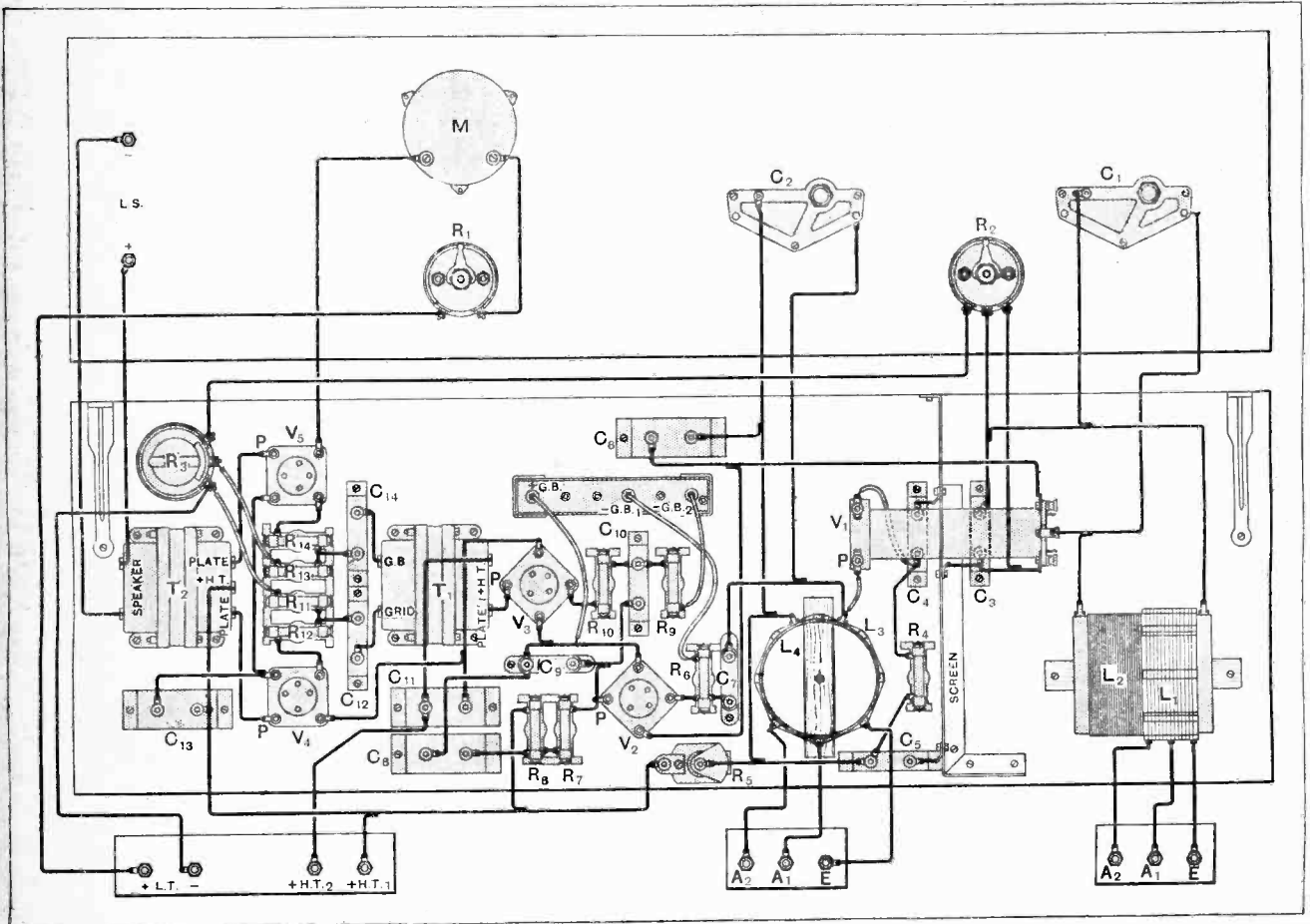

Fig. 9.—Wiring diagram of receiver. Components are lettered to correspond with the theoretical diagram, Fig. 6.

The only trouble likely to be met with, apart from any arising through wrong connections, is the inevitable hum. The receiver, while in course of development, was tested on two separate mains systems, and in one case the positive pole, and in the other the negative, was earthed. These different conditions did not necessitate any variation in the design of the receiver or eliminator in order to accommodate them, but it was found essential to make the earth connection to different points in the two cases. This done, the two mains-systems gave identical results.

When using the mains with the negative pole earthed, the earth lead was taken to the two terminals provided for that purpose, one of which is on the set, and the

which may be set off against the comparatively high cost of construction. From 250-volt mains, with which the consumption will be at its highest, 25 watts will be consumed in lighting the filaments of the valves and energising the magnet of the loud speaker, with an additional 5 watts or thereabouts for the high-tension current.

This means that the whole demands of the receiver are less than that of the smallest electric lamp that is likely to be in use for ordinary room lighting, or, to put it in terms of actual money, a ten-shilling note would just about cover the cost of a year's running at the average rate of two hours daily.

Six hours a penny!

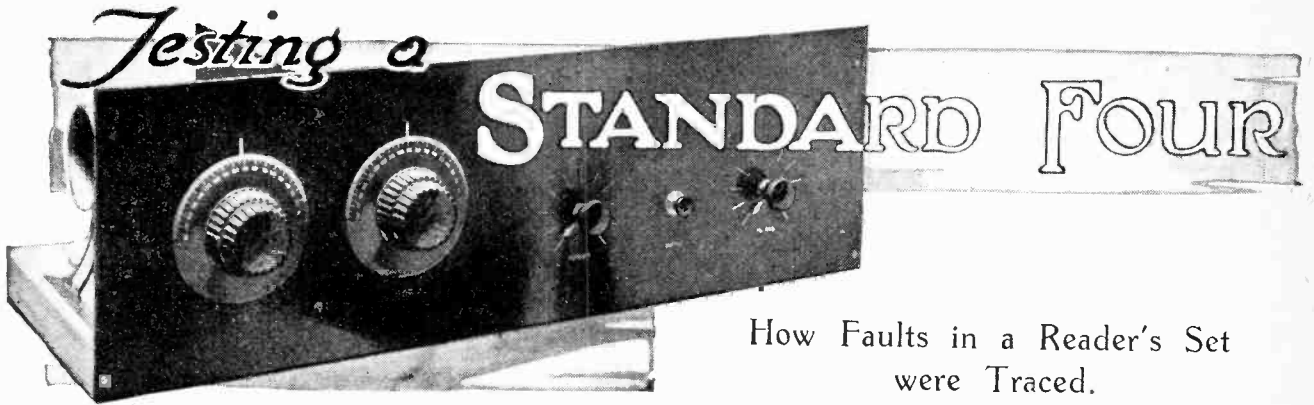

How Faults in a Reader's Set were Traced.

Of all the different queries with which the Information Department staff have to deal, the most difficult to answer helpfully are those relating to the tracing of faults in receivers; in many cases it is quite impossible for the querist adequately to describe the symptoms, with the result that very often—far more often than we would wish—no more can be done than to make one or two suggestions and to recommend careful stage-by-stage and point-to-point tests. Experience goes to show that there is almost always a simple explanation for the apparently mysterious fault, but as there are literally dozens of points at which failure may occur, a mere guess without substantial foundation is almost certain to be wide of the mark. The real trouble appears to be that the home constructor who is sufficiently experienced to describe those symptoms which are likely to lead to a correct diagnosis, and to ignore non-essentials, will naturally be able to trace a fault himself, and therefore will not write to us at all.

There is no real short cut to the location of faults, and unless one is fortunate enough to hit upon the trouble after a few minutes, it is best to abandon haphazard methods, and to go over the set systematically. Although it is an instance of the natural perversity of

inanimate objects that the defect is so often found to exist in the last component to be tested, this need not deter us, as the complete operation may be carried out in a surprisingly short time, always provided that one knows how to set about it.

Elaborate Testing Equipment Unnecessary.

In order to suggest a suitable method of procedure, the writer (a member of the Information Department staff) will describe in detail how he cleared faults in a reader's version of the "Standard Four," which came into his hands, in the hope that the information will be of use to those in difficulties. No apparatus other than a two-range voltmeter and a pair of phones with a dry cell was used. The set is representative of several popular *Wireless World* receivers, to which the methods to be discussed are applicable without modification, or, at any rate, with such modifications as will be sufficiently obvious. The actual instrument tested is illustrated on this and the succeeding page.

With one exception, to be discussed later, the set did not deviate seriously from the published design,

¹ *The Wireless World*, November 30th, 1927.

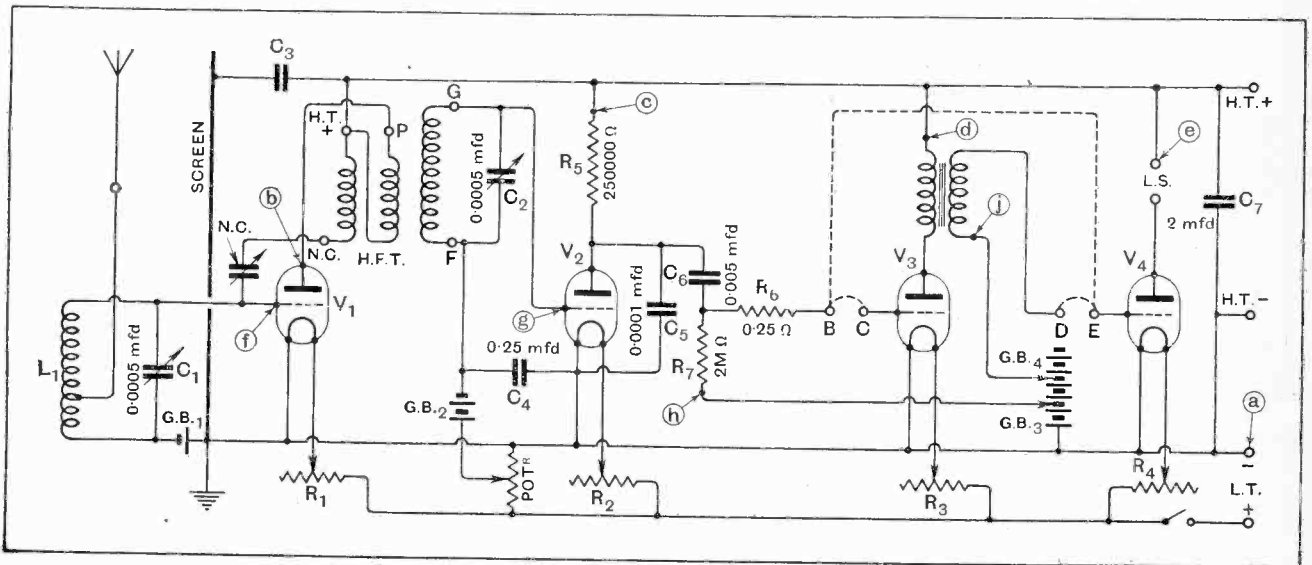

Fig. 1.—The circuit diagram of the receiver. Contact points for carrying out the various tests described are shown.

Testing a Standard Four.—

although the optional tuned aerial circuit had been omitted and a conventional method of construction had been adopted in place of a baseboard layout. It was complained that both selectivity and sensitivity were poor, and that there was "some distortion"; from this meagre information it will be admitted that it was impossible to form any definite opinion as to the causes of its shortcomings.

Batteries were connected, and the set was switched on; a few moments' listening proved that the complaints were justified. The first step was to test the voltage existing directly across the filament terminals of each valve while they were actually taking current. The H.F. amplifier, detector, and first L.F. amplifier were in order, but a pressure of slightly under five volts was indicated in the output stage. Examination showed that the semi-fixed resistor in series with the filament of this valve (a P.M.256) was of about 30 ohms maximum—an altogether excessive value for a valve consuming a quarter of an ampere. Moreover, it had no "zero" position; with the slider at the end of its travel some five ohms remained in circuit. This might conceivably account for poor quality, as it would be responsible for a reduced emission. The fault was partially remedied by bending the slider.

The next task was to check the continuity of the anode circuits and, as far as possible, the anode voltages, by connecting one side of the meter to the negative L.T. bus-bar (point *a* in Fig. 1) and the other side, in turn, to points *b*, *c*, *d*, and *e*. So far as the H.F. valve V_1 is concerned, the test can be made conclusively, as the ohmic resistance of the transformer primary is negligible, but in the other circuits it must be completed between the points mentioned and the actual anode terminals by using phones and dry cell, which will show at least that there is no "open circuit." The receiver came through these tests without any trouble.

In order to find out if there was a break in any of the grid circuits, and also to measure the bias voltages applied, the positive meter terminal was joined to point *a*, its negative lead being connected successively to points *f*, *g*, *h*, and *j*. Connected in this way, the instrument should give a true indication of grid voltage impressed on V_1 , and an approximately true indication of that of the detector V_2 ; in the case of the latter, this will only be so if the meter is of high resistance, or if the potentiometer slider is set near the negative end of its winding. Tests of the grid circuits of V_3 and V_4 must be completed with phones and dry cell, due to the high resistance of the grid leak and transformer secondary.

These tests brought to light the real cause of the con-

structor's difficulty; as no voltage was shown between the H.F. valve grid and filament, a disconnection in L_1 , G.B.₁, or the associated leads was clearly indicated. This was finally traced to the socket for the low-potential pin fitted to L_1 ; its ebonite sleeve was of an excessive length, with the result that the soldering tag was not in contact with the metal, and the grid circuit was completed only through the stray capacities.

After this matter had been remedied, the set was again tested; its performance was more normal, but sensitivity was practically nil. Naturally enough, it was assumed that the remaining coil-base socket might well be at fault, and a test showed that this suspicion was justified; again, a complete lack of continuity was found, due to exactly the same cause as before. After the ebonite sleeve had been shortened, contact was restored, and the



The "Standard Four," as constructed by a reader. Faults were located in the base of the aerial-grid coil, which is seen at the extreme right-hand side of the photograph.

performance of the receiver left very little to be desired.

It was observed, however, that the spacing between the grid end of L_1 and the screen was appreciably less than in the original model as described. This gave rise to an uneasy feeling that perhaps the set was capable of improvement, and, to clear up the matter, valve voltmeter measurements were made against a standard. This proved, as expected, that there was sufficient loss to be detectable, but hardly enough to be audible.

A careful consideration of the circuit diagram will show that simple tests as described are likely to reveal the kind of fault which is responsible for the majority of the amateur's difficulties, which, it should be emphasised, are generally due to defects very similar to those met with in the set actually tested. In cases where these methods fail, we must go further, and carry out point-to-point and stage-by-stage tests, in the manner advocated from time to time in this journal.

Although the defects which came to light were so simple, they were sufficiently obscure to baffle the builder of the set; therefore it seems probable that other readers are, or will be, in similar difficulties, in which case these notes may be of some assistance to them. Even if one's receiver is at present functioning in an unexceptionable manner, it is a good plan to prepare for trouble by memorising the details of a method of procedure which will generally yield the desired results.

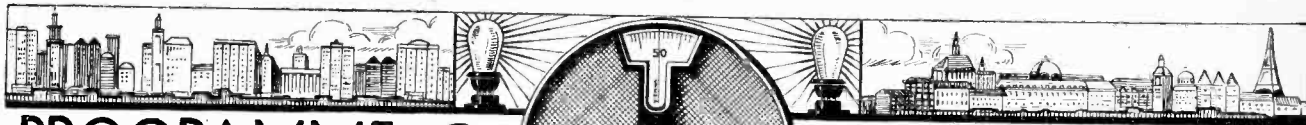

PROGRAMMES

FROM ABROAD



SATURDAY, JULY 28th.

All Times are reduced to British Summer Time and are p.m. except where otherwise stated.

BARCELONA (Radio-Barcelona), Call EAJJ (344.3 metres); 1.5 kW.—6.15, Divine Service. 6.25, Sextet Selections: Selection from Le Roi de Lahore (Massenet); Chanson folle (Fraucheschli); Spanish Serenade (Bizet). 9.0, Exchange Quotations and News. 9.5, Orchestral Selections: Indian March, Taj Mahal (Hansen); Apassionat (Casademont); Cancó d'antena (Vilar); Potpourri of Popular Catalanian Airs (Gironella); Sérénade à l'enfant (Flament); Overture to Zampa (Herold). 10.0, Chimes, Weather Report and News. 10.5, Programme relayed from Madrid, EAJJ.

BERGEN (370.4 metres); 1.5 kW.—11.15 a.m., Exchange Quotations. 12.15, Weather Report and News. 8.0, Orchestral Concert from the Hotel Norge: Slavonic Dance, No. 10 (Dvorák); Passepied (Delibes); Selection from La Traviata (Verdi); Selection (Grieg); Si-Bienne and Intermezzo from Cavalleria Rusticana (Mascagni); Selection from Zigennerprimas (Kalmán). 9.0, Talk, by Brynjulv Fauske. 9.30, Recitations by Sverre Eriksen. 10.0, Weather Report, News and Time Signal. 10.15, Dance Music, relayed from the Hotel Norge.

BERLIN (Königswusterhausen) (1,250 metres); 40 kW.—5.0, Programme from Hamburg. 6.0, Talk by Dr. Wiehaff. 6.30, Dr. Vollmberg, Talk: Between Panama and Canada. 6.55, Talk: The Comic Element in Pianoforte Music. 7.20, Talk: Goethe and the Creative Art of his day. 8.30, Programme from Voxhaus.

BERLIN (Voxhaus) (484 metres); 4 kW.—6.0 a.m., Morning Gymnastics. 10.10 a.m., Market Prices. 10.15 a.m., Weather Report, News and Time Signal. 11.0 a.m., Programme of Gramophone Records. 11.30 a.m., Exchange Quotations. 12.55, Time Signal. 1.30, Weather Report and News. 3.10, Agricultural Prices and Time Signal. 3.30, Programme of Gramophone Records. 4.30, E. Nebelmann, Talk: Chess. 5.0, Humorous Sports Talk by Charlie K. Roellinghoff. 5.30, Orchestral Concert. 6.45, Dr. Arno Schirokauer, Talk: "German Poet" Travels—The Poet and the Alps. 7.15, Hedwig Landsberg, Talk: Sick Nursing. 7.45, Dr. Carl Würzburger and Dr. Hans Hajek: Round the World. 8.30, "Der Jongleur," Berlin Sketch (Emil Pohl), followed by Weather Report, News, Time Signal and Sports Notes. 10.30, Dance Music. 12.30 a.m. (approx.) (Sunday), Close Down.

BERN (411 metres); 1.5 kW.—8.0, Time Signal and Weather Report. 8.5 (approx.), Concert: The Mandoline Orchestra, Anecdotes and Readings. 9.30, Programme by the Berne Orchestra, News and Weather in the Interval. 10.35, Dance Music. 12.9 Midnight (approx.), Close Down.

BRESLAU (322.6 metres); 4 kW.—4.30, Orchestral Concert. 5.0, Programme from Cologne. 5.45, Orchestral Concert. 6.15, Esperanto Talk by Margarete Polier. 6.30, Alfons Haviduk, Talk: Adventures, and Remarkable Events in Upper Silesia. 7.25, Review of Art and Literature. 7.50, English Lesson by Douglas Yates, M.A. 8.30, Concert, Talk by Alexander Feit; Pressa Marsch (Eysoldt); Variety Items by Carl Rolf Augustin; Pizzicato-Waltz, Pavlova (Meyer-Helmund); Song; (a) Sag ich blau, sagt sie grün (Berger), (b) Ich hatt' Dich so gerne hoch mal gesehen (Engel-Berger), (c) Sei nicht dümm nur behüt dein Herz (Römer); Variety Items by Carl Rolf Augustin: Intermezzo, Flirt sous Bois (de Taeye); Tango, Mädel, ich will ja immer nur gut zu Dir sein (Gollwell); Variety Items by Carl Rolf Augustin: Old Viennese Waltz Hylde, Das ist der Herr von Schimbert (Arnold); Wenn Dich die Menschen auch kränken (Arnold); Songs; (a) Wenn man nicht gut chinesisch kann (Nussbaum), (b) Mein Mann, der Adrian (Krausz), (c) Frühlingstraume (Kollo), (d) Mein Herz ist eine Jazzband (Engel-Berger); March, Hoch Heidecksburg. 10.0, News. 10.30, Programme from Voxhaus. 12.0 Midnight (approx.), Close Down.

BRUNN (441.2 metres); 3 kW.—6.0, Time Signal and German Transmission. 6.25, Programme of Talks. 7.15, Orchestral Selections. 8.0, Serenade (Paukner). 8.30, Programme of Popular Music. 9.0, Orchestral Selections. 10.0, Exhibition Programme. 10.25, Orchestral Selections.

BRUSSELS (508.5 metres); 1.5 kW.—5.0, Dance Music from the St. Sauveur Palais de Danse. 6.0,

HAMBURG, Call HA (in Morse), (394.7 metres); 4 kW.—10.15 a.m., News. 11.0 a.m., Programme of Gramophone Records. 12.10, Weather Report. 12.15, Exchange Quotations. 12.30, Concert from Hanover (297 metres). 12.45 (in the Interval), Shipping Forecast. 12.55, Time Signal. 1.10, News. 2.40, Exchange Quotations. 3.30, Review of Books. 4.0, Labour Exchange Report. 4.15, Dr. W. Heinitz, Talk: How do we hear music? 5.0, Concert from the works of Schumann: Overture to Genoveva; Songs, (a) Widmung, (b) Der arme Peter; Overture, Scherzo and Finale, op. 52. 4.0, Songs, (a) Mit Myrthen und Rosen, (b) Volksliedchen; Overture to Manfred. 6.0, Request Programme. 7.0, Talk from Kiel (251.2 metres). 7.30, Theobald Bieder; Talk: The Constellations in August. 7.55, Weather Report. 8.0, "The Return from Leave" Variety Concert, followed by News, Sports Notes, and Programme Announcements. 10.30 (approx.), Cabaret Programme.

HILVERSUM (1,071 metres); 5 kW.—11.40 a.m., Police News. 12.10, Concert of Trio Music. 1.40, Concert, relayed from the Tuschinski Theatre. 4.10, The Dansant, relayed from the Kurhaus, Scheveningen. 5.40, Time Signal. 5.42, Concert; Selection from Overtures (Engelman), Waltz, Flattergeister (Jos. Strauss); Minuet (Kostal); Soirée intime (Lincke); Selection from La Bohème (Puccini); Valse lente, Waldnixe (Ertl); Czardas, Le dernier amour (Gung'l); Selection from the works of Offenbach (Morena); Grossmutterchen (Langer); Waltz, Dorfkind (Kalmán); Von Heidelberg bis Barcelona (Borchert); Finale. 7.25, Police News. 7.40, Programme organised by the Workers' Radio Society; Concert and Talk. 11.15 (approx.), Close Down.

HUIZEN (340.9 metres); 4 kW.—Transmits from 5.40 on 1,870 metres. 12.10, Concert of Trio Music. 5.10, Gramophone Selections. 6.40, M. J. v. Roosmaalen, Talk: Horticulture. 7.20, Talk by Dr. J. Stein. 7.55, Concert of Violin, Cello and Pianoforte Solos, and Songs.

JUAN-LES-PINS (Radio L.L.), (244.5 metres); 1.5 kW.—1.0, Orchestral Concert: Ni veuve ni joyeuse (Fauchey); Punka Wallah (Collin); Danse violée (Candioli); Il Seraglio (Mozart); Mon cœur soupire (Mozart). Ils sont finis les jours d'ivresse (Lémine); De Jo Dolga (Barch); Gillette de Narbonne (Audran). 9.0, Concert, followed by News and Weather Report. 10.0, Dance Music. 10.30 (approx.), Close Down.

KALUNDBORG (1,153 metres); 7 kW.—Programme also for Copenhagen (337 metres). 7.30 a.m., Morning Gymnastics. 11.0 a.m., Weather Report. 3.0, Trio Concert: Turkish March (Mozart); Waltz, The Blue Danube (Joh. Strauss); Selection from Madame Butterfly (Puccini); Gavotte in B Flat Major (Corelli); Tambourin (Gossec); Cello Solo, Allegro appassionata (Saint-Saens); Humoresque (Dvorák); Recitation; March, The Handicap (Rosey); Waltz, Barcarolle (Waldteufel); Tango, The Spanish Girl (Fleta); Waltz, Alone to (Rydalbi); Selection from Les Cloches de Corneville (Planquette); Serenade (Toselli); Foxtrot, Det vi kalder kærlighed (Reesen and Norman). 6.50, Weather Report. 7.15, Time Signal. 7.20, Programme Announcements. 7.30, Talk. 8.0, Chimes from the Town Hall. 8.2, Concert of Old Dance Music: March, Kongemøde (Jespersen); Spanish Waltz, Torero (Tradition); Polka, Ringel, ringel, reia (Suppé); Tyrolian Waltz and Dance, Sekstur, Trippevals (Nielsen); Mazurka (Kliment); Polka, Ihr ganzes Glück (Fahrbach); Waltz, Donaubaiger (Ivanovic); Lot' ist tot, Wera-Galop (Michaelis); Forgangen Nat. 9.0, News. 9.15, Variety Concert. 10.45, Dance Music. 12.0 Midnight, Chimes from the Town Hall, Copenhagen. 12.15 a.m. (approx.), (Sunday), Close Down.

KATOWITZ (422 metres); 10 kW.—6.0, Programme for Children. 7.0, Miscellaneous Items. 7.30, Talk by Dr. Zahuski. 7.55, The Children's Letter Box. 8.15, Programme relayed from Warsaw. 10.0, Time Signal, Weather Report and News. 10.30, Dance Music.

KAUNAS (2,000 metres); 7 kW.—12.0 Noon, Carillon. 7.0, Gramophone Selections. 9.0, The Disabled Soldiers' Orchestra. 10.0, Dance Music.

Elementary English Lesson. 6.25, Advanced English Lesson. 6.45, Orchestral Concert: Marche Russe (Ganne); Forgive Me (Ager); Persian Rosebud (Nicholls); C'est Vous (Greenberg); Milady (Benatzky); Dolores (Waldteufel); Flute Solo, Souvenir de Mons (Danhier); Selection from Manon Lescaut (Puccini); Suite (Smalstich). 7.30, "Radio-Chronique." 8.15, Gramophone Selections. 8.30, Literary Programme. 8.50, Talk on Topical Events. 9.0, Symphony Concert, relayed from the Kursaal, Ostend. 10.15, News. 10.30 (approx.), Close Down.

BUDAPEST (555.6 metres); 35 kW.—6.0, Concert of Military Music, from the Angol Park. 7.0, Literary Talk. 7.45, "Cigánykirsly" Operetta (Nagyvdj); In the interval: Time, News and Racing Results. 10.50, Concert of Tzigane Music, relayed from the Spolarits Café. 12.0 Midnight (approx.), Close Down.

COLOGNE (283 metres); 4 kW.—10.35 a.m. to 2.30, Programme from Langenberg. 2.30, Talk: Hints for the Housewife. 3.40 to 4.30, see Langenberg. 4.30, Talk from Königswusterhausen. 5 to 7.20, see Langenberg. 7.20, Dr. Hans Stein, Talk for Workers: Rheinisch and Westphalian Social Leaders of the Past. 7.45, See Langenberg. 8.10, Five Minutes Talk on the German Athletic Festival. 8.15, Programme from Dortmund (see Langenberg), followed by News, Sports, Notes, Concert and Dance Music. 1.0 a.m. (approx.), (Sunday), Close Down.

CRACOW (586 metres); 1.5 kW.—6, Programme for Children. 7.0, Miscellaneous Items. 7.30, Talk: Review of the past week's Foreign Politics. 7.55, Agricultural Report. 8.5, News and Announcements. 8.15, Programme, relayed from Warsaw. 10.30, Concert from a Restaurant. 11.30 (approx.), Close Down.

DUBLIN, Call 2RN (319.1 metres); 1.5 kW.—1.30, Weather Report and Gramophone Selections. 7.20, News. 7.30, Reading by Frank Fav. 7.45, Irish Talk by Seamus O'Duinnne. 8.0, Orchestral Selections. 8.15, Joseph Schofield (Cello), and Mary Maguire (Mezzo-Soprano). 8.45, Baritone Solos by Glyn Eastman. 8.55, Orchestral Selections. 9.5, Baritone Solos by Glyn Eastman. 9.20, "Exile," Sketch by J. A. Hand and Company. 9.30, Orchestral Selections. 10.5, Soprano Solos by Mamie Dingle. 10.30, News, Weather Report, and Close Down.

FRANKFURT (428.6 metres); 4 kW.—1.0, Gramophone Records. 3.30, Children's Corner. 4.15, Reading. 4.35, Orchestral Concert: Overture to the Suite in B Minor for Flute, Pianoforte, and Strings (Bach); Aria, with Violin obbligato from the Cantata No. 24 (Bach); Organ Solo, Toccata and Fugue in D Minor (Bach); Akademische Festouvertüre (Brahms); Songs; (a) Auf dem See, (b) Wenn du nur zuweilen lächelst, (c) Wehe, so willst du mich; Abendmusik, op. 79, No. 2 (Foerster); Suite, Ein Märchen (Suk). 6.15, Wireless Notes and Announcements. 6.30, Answers to Correspondents and Announcements. 6.35, "Talk and Reading." 7.15, Prof. Dr. Franz Schultz, Talk: The German Drama and Theatre from the 17th century up to the present day. 7.45, Educational Talk by Dr. W. Schuckmann. 8.15, Variety Programme. 10-15, (approx.), Programme from Voxhaus.

Saturday, July 28th.

Programmes from Abroad.—

LAHTI (1,522.8 metres); 35 kW.—5.0, Orchestral Concert: March (Kral); Overture to Martha (Flotow); Wenn die Sonne lacht (Siede). 5.20, Recital of Songs, followed by Selections from A Waltz and Dream (Strauss). 5.57, Time, Weather Report and News. 6.15, Orchestral Concert: Serenata Espagnole (Lugini); Paraphrase, Lorelei (Nesradba); Hungarian Songs (Brunnhofner); Salut d'Amour (Elgar); Du mein Schönbrunn (Fall). 7.30, Recital of Cello Solos. 7.50, Orchestral Concert: Melodies from The Pearl Fishers (Bizet); Skizzen (Godard); Waltz (Olsen); Berceuse de Jocelyn (Godard); Waltz (Miami (Jacobi)); Korimodsglanz (Lange-Müller); March (Dicker). 8.45, News, given in Finnish and Swedish, followed by Concert relayed from a Restaurant. 10.0 (approx.), Close Down.

LANGENBERG (468.8 metres); 20 kW.—Programme also for Aix-la-Chapelle (400 metres), Cologne (283 metres) and Münster (250 metres).—11.15 a.m., Programme for Schools. 12.10, Music. 12.50, Weather Report. 12.55, Time Signal. 1.5, Concert from Elberfeld: Organ Solo (Zamecnik); Overture to Mignon (Beccce); Waltz, Ganz Paris (Waldfteufel); Sicilienne from Cavalleria Rusticana (Mascagni); Südländische Rhapsodie (Hosmer); Serenade, Des Schiffer's Abendgang (Mercadente); Ständchen (Mario Costa); Sicilian Serenade (Beccce); Schützenmarsch (Lippe). 2.30, See Cologne. 3.40, The German Athletic Championship. 4.30, See Königswusterhausen. 5.0, The German Athletic Championship. 5.30, English Lesson, from Münster. 6.0, Concert from Düsseldorf: Mezzo-Soprano Solos (Bralms), (a) Mainacht, (b) An ein Veilchen, (c) Mädchenlied, (d) Piano Solo, Ballade in B Minor (Liszt); Mezzo-Soprano Solos (Grieg), (a) Die Prinzessin, (b) Herbststimmung, (c) Lauf der Welt; Pianoforte Solo, Ballade in G Minor (Grieg). 7.20, See Cologne. 7.45, Talk from Münster. 8.10, See Cologne. 8.15, Variety Programme from Dortmund, followed by Programme from Cologne. 1.0 a.m. (approx.) (Sunday), Close Down.

LEIPZIG (365.8 metres); 4 kW.—4.30, Orchestral Concert. 5.0 (in the interval), Programme from Cologne. 6.0, See Königswusterhausen. 6.30, Answers to Correspondents. 7.0, Dr. Max Schneider, Talk: The Modern Zoo. 7.30, Fritz Osswald, Talk: Wandering across the Saxon Plains. 8.0, Weather Report and Time Signal. 8.15, Concert of German Musical Play Melodies: Overture to Der betrogene Kadi (Mozart); Two Arias from Der betrogene Kadi (Gluck); Duet from Der betrogene Kadi (Gluck); Overture to Die Schweizerfamilie (Weigl); Song from Die Schweizerfamilie (Weigl); Song from Jugendjahre Peter des Grossen; Duet from Jugendjahre Peter des Grossen; Duet from Abu Hassan; Aria from Zwillingsbrüder (Schubert); Aria from Alfonso and Estrella (Schubert); Music from Die drei Pintos (Weber); Duet from Die Liebe auf dem Lande (Hiller); Overture to Die Opernprobe (Lortzing). 10.0, News and Sports Notes. 10.15, See Voxhans Station. 12.0 Midnight (approx.), Close Down.

LILLE, Call PTT (264 metres); 0.5 kW.—12.30, Orchestral Concert. 1.35, Exchange Quotations. 7.30, Market Prices. 7.40, English Lesson. 8.15, Agricultural Talk. 8.30, Concert and News.

MADRID (Union Radio), Call EAJ7 (375 metres); 3 kW.—7.0, Orchestral Selections: Trianeras (Vives); Selection from Mignon (Thomas); Selection from Una Aventura en Paris (Luna); in the interval, Items by Luis Medina. 8.0, Dance Music. 9.45, Market Quotations. 10.0, Time Signal. 10.2, "A Midsummer Night's Dream," Comedy (Shakespeare). 11.50, News. 12.0 Midnight (approx.), Dance Music. 12.30 a.m. (approx.) (Sunday), Close Down.

MILAN, Call IMI (528.3 metres); 7 kW.—8.35, Time Signal and Talk on "Verdi." 8.50, Concert: Sylvia (Delibes); Song from Romeo and Juliet (Vaccari); Aria from Faust (Gounod); Viola Solos; Tenor Solos; Reading (Shelley); Aria from Dinorah (Meyerbeer); Songs, Aria from Iris (Mascagni); Sylvia (Delibes). 10.55, News and Dance Music from the Fiaschetta Toscana.

MOTALA (1,380 metres); 30 kW.—Programme also for Stockholm (454.5 metres), Boden (1,190 metres), Göteborg (416.5 metres), Malmö (200.9 metres), Östersund (720 metres), Sundsvall (545.6 metres).—5.30, Concert of Light Music. 6.25, Programme for Children. 7.0, Programme from Jönköping (201.3 metres), Choral Concert of Folk Melodies. 7.45, Topical Talk. 8.0, Cabaret Concert, News in the interval. 9.45, Report of the Olympic Games at Amsterdam. 10.0, Dance Music. 1.0 a.m. (approx.), (Sunday), Close Down.

NAPLES, Call INA (333.3 metres); 1.5 kW.—8.40, Time Signal and News. 8.50, Orchestral Selections: Roma (Bizet); Country Scenes (Fletcher); Suite poétique (Dvorák), 9.30, Relay from a Theatre. 10.0 (in the interval), Weekly Review, Dance Music

All Times are reduced to British Summer Time and are p.m. except where otherwise stated.

from the Trocadero. 10.55, Calendar and Announcements. 11.0 (approx.), Close Down.

OSLO (461.5 metres); 1.5 kW.—Programme, relayed by Fredriksstad (434.8 metres), Hamar (555.6 metres), and Notodden (411 metres). Forsgrudn (500 metres), and Rjukan (418 metres). 7.45, Weather Report, News and Agricultural Notes. 8.0, Time Signal. 8.2, Concert, relayed from Hamar. 9.0, Talk. Weather Report and News. 9.45, Topical Talk. 10.0, Dance Music, relayed from the Grand Hotel. 12.0 Midnight (approx.), Close Down.

PARIS (Ecole Supérieure), Call FPTT (458 metres); 0.5 kW.—Programme relayed at intervals by the following stations: Bordeaux PTT (275 metres), Eiffel Tower (2,650 metres), Grenoble (416 metres), Lille, PTT (264 metres), Limoges (285 metres), Lyons, PTT (476 metres), Marseilles (303 metres), Rennes PTT (476 metres), Versailles (260 metres)—8.15, Sports Talk and Notes. 9.0, Concert by the Association Générale des Auditeurs de T.S.F., followed by Dance Music from the Coliseum of Paris.

PARIS (Eiffel Tower), Call FL (2,650 metres); 5 kW.—8.45, "Le Journal Parlé." 8.10, Weather Report. 8.30, Concert: Bucoliques (Dulaurens); Feuillet d'Album (Lévaillé); Revue des amours (Lullu); Ariette (Rosa); Serenade (Schubert); Berceuse (Gaubert); Danses arabes (Grumbach); L'Hermitte (Périllon); Songs (Messager); Les Héritiques (Lévaillé); Les danses de chez nous (Lévaillé).

PARIS (Petite Parisien), (340.9 metres); 0.5 kW.—8.45, Gramophone Records and Talk, News. 9.0, Concert: Prelude to Monna Vanna (Février); Selections from The Merry Wives of Windsor (Nicolaï); The Oxford Symphony (Haydn); Allegro de Roma (Bizet); Ballet Music, The Heretics (Lévaillé), Idylle (Chabrier); Slavonic Dance (Tchaikovsky); News.

PARIS (Radio-Paris), Call CFR (1,750 metres); 6 kW.—12.30, "Columbia" Gramophone Concert: Nocturne and Fête (Debussy); Nuages (Debussy); The Second Symphony (Beethoven); Trio for Piano, Oboe, and Bassoon (Poulenc); There's a rickety rickety Shack, Miss Annabelle Lee; News in the interval. 1.50, Market Prices, Exchange Quotations and Religious Information. 3.45, Dance Music, followed by News. 8.0, Agricultural Report. 8.15, Medical Talk on "Water." 8.25, Exchange Quotations and News. 8.30, Concert: Cantate pour tous les temps (Bach); Cello Solos (Fauré), (a) Après un rêve, (b) Sicilienne, (c) Papillon; La Chanson du Moulin (Lazzari); Air from Samson and Delilah (Saint-Saëns); Guitar Solos by del Campo; Portraits (Closset); Monsieur Choulenry restera chez lui (Offenbach); News in the intervals.

PITTSBURGH, Call KDKA (63 and 27 metres); 25 kW.—11, Time Signal and Baseball Scores. 11.25, KDKA, Theatrical Calendar. 11.30, The Westinghouse Band. 11.55, Baseball Scores. 12.0 Midnight, Time Signal. 12.2 a.m. (approx.) (Sunday), Band Concert. 12.30 a.m., Home Radio Club Programme: James W. H. Weir, Chairman. 12.45 a.m., Gems of American Literature. 1.0 a.m., Ryker and Mack from WJZ, New York. 1.15 a.m., A Week of the World's Business, from WJZ. 1.30 a.m., Goldman Band Concert, from WJZ. 4.0 a.m., Weather Report Time, Baseball Scores, and Close Down.

POSEN (344.8 metres); 1.5 kW.—7.0, Miscellaneous Items. 7.15, Talk by Mr. Rediger. 7.35, Mr. Swidzinsky, Talk: The Basis of Communism. 8.0, Finance Report. 8.15, Programme from Warsaw. 10.0, Time Signal, News, Weather Report and Miscellaneous Items. 10.40, Dance Music from the Carlton Restaurant. 12.0 Midnight, Concert, arranged by the Maison Philips. 2.0 a.m. (approx.) (Sunday), Close Down.

PRAGUE (348.9 metres); 5 kW.—6.0, German Transmission. 6.25, Agricultural Report. 6.35, Talk for Workers. 7.15, Concert of Popular Music. 10.0, Time, News and Orchestral Selections.

RIGA (526.3 metres); 4 kW.—9.30 a.m., Gramophone Selections. 11.0 a.m., News, Announcements, Market Prices, Exchange Quotations and Weather Report. 6.0, Programme of Talks. 7.0, Concert: Symphony in C Major (Haydn); Songs: Viola Solo; Songs; Recitations; Ballet Suite (Lalo); Selection from

Lucrezia Borgia (Donizetti); Selection from Zaza (Leoncavallo); News; Dance Music. 11.0 (approx.), Close Down.

ROME, Call IRO (450 metres); 3 kW.—1.30, Opening Signal. 1.32, Concert of Trio Music. 4.40, News. 4.50, Children's Corner. 5.15, Agricultural Report. 5.29, Time Signal. 5.30, Concert: Sonata in G Minor, Op. 22, for Pianoforte (Schumann); Un certo non so che (Vivaldi); Mezzo-Soprano Solo from Egmont (Beethoven); Tenor Solo, Inno (Casimiri); Tenor Solo from Edmea (Catalani); Noite di maggio (Palmgren); Pianoforte Solo, Festa campestre (Zanella); Mezzo-Soprano Solos, (a) Mater dolorosa from Beatitudini, (b) Io di saluti ve ne mando mille (Wolf-Ferrari); Tenor Solos, (a) Cavatina from Il Conte Ory (Rossini), (b) Aria from La Juive (Halévy). 8.30, Sports Notes, News and Weather Report. 8.59, Time Signal. 9.0, "Samson and Delilah," Opera in Three Acts (Saint-Saëns); Talk in the interval: 11.5, News. 11.15 (approx.), Close Down.

SCHAERBEEK (230 metres); 1.5 kW.—9.30, Concert. Dreamy Paradise (Smidt); Mo-na-iv (Breain); My Land of Memory (Behr); Dreamy Hawaii (Vandersloot); In My Tippy Canoe (Fisher); Dream Kiss (Rienzo); Dripping (Lamb Polla); Tripoli (Weill); Canha Medley, Ka Lua (Kern). 10.15, Concert by the Coliseum Orchestra. 12.0 Midnight, Dance Music. 1.0 a.m. (approx.) (Sunday), News and Close Down.

SCHENECTADY, Call 2XAD and 2XAF (21.96 and 31.4 metres), 30 kW.—11.25, Baseball Scores. 11.30, Dinner Music. 12.25 a.m. (approx.) (Sunday), Baseball Scores. 12.30 a.m., Slaters' Pennsylvanians, directed by Johnny Johnson, from New York. 1.0 a.m., Keystone Duo with Balladers, from New York. 1.30 a.m., Time Signal. 1.32 a.m., The New York Philharmonic Orchestra, conducted by Willem Van Hoogstraten, from the Lewisohn Stadium. 3.20 a.m., Organ Recital by Robert Berentzen, from Rochester. 4.0 a.m., Dance Music from the Hotel Ten Eyck, Albany. 5.0 a.m. (approx.), Close Down.

STAMBOUL (1,200 metres); 5 kW.—4.30, Orchestral Concert. 5.30, Market Prices. 6.15, Concert of Turkish Music. 8.30, Weather Report and Time Signal. 8.40, Concert: Overture to Benvenuto Cellini (Berlioz); Songs and Chorus; Andante from the Seventh Symphony (Beethoven). 10.0, News and Close Down.

STUTTGART (379.7 metres); 4 kW.—6.0, Time Signal and Weather Report. 6.15, Talk from Freiburg (377 metres). 6.45, Report of the South-West German Labour Centre, Time Signal and Sports Notes. 8.15, Chamber Music: String Trio in D Minor (Reger); Sonata for Violin in G Major (Tartini), followed by Cabaret Concert, including "Sende zu Hause," Sketch (Carl Struve), News and Concert from the Café-Restaurant Wilhelmshaus.

TOULOUSE (Radiophonie du Midi) (391 metres); 3 kW.—12.30, The Fourth Concerto, in G Major (Beethoven), followed by Military Concert. 8.0, Time Signal, News and Exchange Quotations. 8.30, Trio in D Minor for Pianoforte, Violin and Cello (Meindelssohn). 9.0, Sonata for Flute, Viola and Harp (Debussy), followed by Instrumental Concert: Clair de Lune; Accordion Solo, Souvenir de Montreuil; Clarinet Solo, The Boss of the Stomps; Trumpet Selection, Ivresse d'Amour; Mandoline Selection, Pizzicato de Concert; Mandoline Selection, Les Millions d'Arlequin (Rigaud); Accordion Solo, Fox-Trot-Charleston, Kahlari; Mandoline Selection, Gavotte Louis XIII (Henze), followed by Dance Music. 10.15, North African News.

VIENNA (577 and 517.2 metres); 1.5 and 5 kW.—6.5, Concert: Aria from Der Waffenschmid (Lortzing); Bird Song from I Pagliacci (Leoncavallo); Violin Solos, (a) Chaconne (Vitali), (b) Minuet (Haydn), (c) Mazurka (Wieniawsky); Selections (Schubert), (a) Nachtwind, (b) Auf dem Wasser zu singen, (c) Jungling an der Quelle, (d) Seligkeit; Pianoforte Solos, (a) Scherzo in F Sharp (Chopin), (b) Geschichten aus dem Wienerwald (Joh. Strauss). 7.0, Selections from the Works of Ottokar Kernstock. 8.5, "Schwarzwalddänel," Operetta in Three Acts (Neidhart), followed by Dance Music.

WARSAW (1,111 metres); 10 kW.—7.0, Miscellaneous Items. 7.30, Mr. St. Grek, Talk on Travelling: Dubrownik-Raguse. 7.55, Agricultural Notes. 8.15, Orchestral Concert: March, Barataria (Komzak); Overture to Der Freischütz (Weber); Waltz, Mon Rêve (Waldfteufel); Gavotte, Les Sylphides (Léhar); Hungarian Dance in G Minor (Brahms); Potpourri, Le Trefileur (Léhar); Le Chant du Soldat (Montiuszok); L'Orchestre Approche (O. Strauss); Song; Recitations; Polonaise from Eugen Onegin (Tchaikovsky); Polka, Hélène (Wronsky); Mazurka, Les Noces à Ojcow (Lewandowsky); Galop, En Carrière (Komzak); News in French during the interval. 10.0, Time Signal, Aviation Notes, Weather Report, News and Sports Notes. 10.30, Dance Music from the Oaza Restaurant. 11.30 (approx.), Close Down.

SUNDAY, JULY 29th.

All Times are reduced to British
Summer Time and are p.m. except
where otherwise stated.

Programmes from Abroad.—

BARCELONA (Radio-Barcelona), Call EAJI (344.8 metres); 1.5 kW.—12 Noon, Chimes from the Barcelona Cathedral, Regional and General Weather Report. 1.30, Selections by the Iberia Trio, Gramophone Records. 2.45 to 9.0, Interval. 9.0, Sports Notes, Agricultural Market Prices. 9.15, The Station Orchestra: in the Intervals Vocal Recital by Antonio Pera (Bartone) and Maria T. Gonzalez (Soprano); Chimes from the Cathedral at 10.0. 11.0 (approx.), Close Down.

BERGEN (370.4 metres); 1.5 kW.—10.30 a.m. Divine Service and Address. 12.30, Weather Forecast and News Bulletin. 8.0, Selections of Orchestral Music, with Soprano Solos by Mrs. Hulda Frisk Gran. 10.0, Weather Forecast, News Bulletin and Time Signal. 10.15, Relay of Dance Music. 12 Midnight, (approx.), Close Down.

BERLIN (Koenigswusterhausen), (1,250 metres); 40 kW.—6.30 a.m., Orchestral Concert, relayed from Voxhaus. 9.0 a.m., Vocal and Instrumental Concert, relayed from Voxhaus, followed by Cathedral Chimes. 11.30 a.m., Concert, relayed from Voxhaus. 2.0, Children's Programme, relayed from Voxhaus. 3.0, Practical Talk for Amateur Photographers by Jens Lützen. 3.30, Agricultural Programme, relayed from Voxhaus. 6.30, Talks by Emv von Vogelsang and Albert Bochelmann, followed by Programme, relayed from Voxhaus.

BERLIN (Voxhaus), 484 metres); 4 kW.—6.30 to 8 a.m., Orchestral Concert. 9.0 a.m., Vocal and Instrumental Concert, followed by Chimes from the Berlin Cathedral. 11.30 to 12.50, Orchestral Concert. 2.0, Children's Programme, arranged by Hans Bodendstedt. 3.30, Programme of Agricultural Talks, followed by Musical Selections. 7.0, Programme of Talks, followed by Musical Programme. 10.30, Dance Music by the Gerhard Hoffmann Orchestra. 12.30 a.m. (approx.) (Monday), Close Down.

BERN (411 metres); 1.5 kW.—10.0 a.m., Relay of a Divine Service, and Sermon. 1.0, Time Signal and Weather Forecast. 1.5, Orchestral Selections. 3.30, Concert of Orchestral Music. 5.35 to 8.0, Interval. 8.0, Time Signal and Weather Forecast, followed by Programme of Music. 9.45, Sports Notes, News Bulletin, and Weather Report. 10.0, Orchestral Concert. 10.35, (approx.), Close Down.

BREMEN (272.7 metres); 0.7 kW.—6.30 a.m., Orchestral Concert, relayed from Berlin. 8.25 a.m., Time Signal, Weather Forecast, News Bulletin, Commerce Notes and Programme Announcements from Hamburg. 9.15 a.m., Morning Recital from Hamburg. 12.55, Nauen Time Signal. 1.0, Instrumental Concert. 2.0, Children's Programme, followed by Programme of Talks and Music. 8.0, Musical Programme, followed by Weather Report, News Bulletin and Concert, relayed from the Georgspalast. 11.0 (approx.), Close Down.

BRESLAU (322.6 metres); 4 kW.—11.0 a.m., Evangelical Morning Recital. 12.0 Noon, Orchestral Concert. 1.6, News Bulletin. 2.0, Competitions. 2.10 to 3.0, Programme of Talks. 3.0, Fairy Tale Recital. 6.30, Weather Forecast. 7.25, Programme of Talks. 8.30, Light Variety Concert, with Ludwig Manfred Lommel in his Repertoire. 10.0, News Bulletin. 10.30, Outside Relay of Dance Music. 12.0 Midnight (approx.), Close Down.

BRUNN (441.2 metres); 3 kW.—9.0 a.m., Agricultural Report. 10.0 a.m., Concert of Sacred Music. 12.0 Noon, Orchestral Concert. 4.0, Popular Concert. 6.0, German Transmission. 7.0, Musical Programme. 10.20, Musical Selections. 11.0 (approx.), Close Down.

BRUSSELS (508.5 metres); 1.5 kW.—5.0, Relay of Dance Music from the Ostend Kursaal. 6.0, Programme for Children. 6.30, Instrumental Concert with Solos. 7.30, "Le Radio-Chronique—Journal Parlé of Radio-Belgique." 8.15, Chamber Music Concert. 9.0, Symphony Concert, conducted by M. François Rasse, relayed from the Ostend Kursaal, followed by News Bulletin. 10.30 (approx.), Close Down.

BUDAPEST (555.6 metres); 35 kW.—9.0 a.m., News Bulletin and Beauty Hints. 10.0 a.m., Divine Service. 12.0 Noon, Chimes from the University Church and Musical Programme. 3.30, Agricultural Talk, followed by Programme of Talks and Music. 6.30 (approx.), Sports Notes, followed by Popular Programme, Sports Notes in the Interval; Tzigane Music at Close of Programme. 12.0 Midnight (approx.), Close Down.

COLOGNE (283 metres); 4 kW.—Programme also for Aix-la-Chapelle (190 metres). Langenberg (168.5 metres) and Münster (250 metres).—8.45 to 9.45 a.m., First Part of the Programme relayed from the German Light Athletics Championship Festival in Cologne; Carnival Procession. 9.30 a.m., Sacred Morning Recital. 12.30 (approx.), Literary Reading. 2.15, See Langenberg Programme. 5.45, Second Part of the German Light Athletics Championship Festival—Open Air Sports and Presentation of Prizes to the Victors. 8.0, Evening Variety Programme, followed by Last News Bulletin, Sports Notes and Orchestral Concert. 12.0 Midnight (approx.), Close Down.

CORK, Call 6CK (400 metres); 1.5 kW.—8.30, Vocal and Instrumental Concert by the No. 2 Army Band, conducted by Lieut. Arthur Duff, Mus.B., and Soloists. 11.0, National Anthem. 11.5 (approx.), Close Down.

CRACOW (566 metres); 1.5 kW.—10.15 to 11.45 a.m., Divine Service, relayed from a Cathedral. 12.0 Noon, Fanfare from Notre Dame in Cracow, Time Signal and Weather Forecast. 4.0, Programme of Agricultural Talks. 4.40, Agricultural Report by Dr. St. Wasniewski. 5.0, Programme relayed from Warsaw. 6.30, Miscellaneous. 6.50, Programme from Warsaw. 8.0, Fanfare, relayed from Notre Dame, followed by Sports Notes. 8.30, Instrumental and Vocal Concert, including recital of Schubert's Songs by Mlle. Miloslawa Dolega-Bursa. 10.0, Programme relayed from Warsaw. 10.30, Concert relayed from a Restaurant. 11.30 (approx.), Close Down.

DUBLIN, Call 2RN (319.1 metres); 1.5 kW.—8.30 to 11.5 (approx.), Programme relayed from the Cork Station; Vocal and Instrumental Concert, featuring Eibhlín Ní Mhurchadha in Selections from the Works of Schubert.

FRANKFURT (428.6 metres); 4 kW.—8.0 a.m., Musical Morning Recital. 11.0 a.m., Talk for Parents on the Upbringing of Children, arranged by Dr. Flesch and Heri K. Wehrhan. 11.30 a.m. to 6.0, Programme of Talks and Music. 6.0, Talk, arranged by the Rhein-Main Association for Popular Education. 8.0 (approx.), Musical Programme, followed by Dance Music relayed from Berlin. 12.30 a.m. (approx.) (Monday), Close Down.

HAMBURG, Call HA (in Morse) (394.7 metres); 4 kW.—Programme relayed by Bremen (272.7 metres). Hanover (297 metres) and Kiel (251.2 metres).—6.30 a.m., Orchestral Concert, relayed from Berlin. 8.25 a.m., Time Signal, Weather Report, News Bulletin and Commerce Notes. 9.10 a.m., Programme Announcements. 9.15 a.m., Morning Recital. 11.0 a.m. (for Hamburg, Hanover and Bremen only), Talk by Dr. Funk. 12.55, Nauen International Time Signal. 1.0 (for Hamburg and Kiel only), Orchestral Studio Concert. 2.0, Musical Programme for Children. 3.0 to 7.40, Programme of Talks and Music. 7.40, Sports Notes and Weather Report. 8.0, Musical Programme, followed by Weather Report, News Bulletin and Concert from the Café Wallhof (for Hamburg and Kiel only). 11.0 (approx.), Close Down.

HANOVER (297 metres); 0.7 kW.—9.30 a.m., Orchestral Concert, relayed from Berlin. 8.25 a.m., Time Signal, Weather Forecast, News Bulletin, Commerce Notes and Programme Announcements from Hamburg. 9.15 a.m., Morning Recital from Hamburg. 11.0 a.m., Talk from Hamburg. 12.55, Nauen Time Signal. 1.0, Gramophone Records, followed by Programme of Talks and Music. 8.0, Musical Programme, followed by Weather Report, News Bulletin and Concert, relayed from the Georgspalast. 11.0 (approx.), Close Down.

HILVERSUM (1,071 metres); 5 kW.—12.40, Lunch Time Trio Concert. 2.40, Orchestral and Soloist Concert, relayed from the Kurhaus in Scheveningen; The Residence Orchestra. 4.30 (approx.), Concert by the Wireless Orchestra, conducted by Nico Treep. 7.40, Weather Report, News Bulletin and Sports Notes. 7.55 (approx.), Concert by the Residence Orchestra from the Kurhaus in Scheveningen, conducted by Professor Georg Schnevoigt.

HUIZEN (340.9 metres); 4 kW.—Programme on 1,950 metres after 5.30. 8.10 a.m., Address and Recital of Sacred Music. 9.30 a.m. (approx.), Protes-

tant Divine Service. 12.10, Concert by the Winkels Trio of Amsterdam, followed by afternoon Programme of Talks and Music. 7.25, Talk. 7.55, Orchestral Concert under the Direction of M. M. v.d. Ende; Artistes, Mr. Carter and Miss Corrina. 10.25 (approx.), Choral Epilogue.

JUAN-LES-PINS (Radio LL) (244.5 metres); 1.5 kW.—1.0 to 2.0, Programme for Children and Concert by the Izar Orchestra, relayed from the Municipal Casino, Juan-les-Pins, followed by News Bulletin. 2.0 to 9.0, Interval. 9.0, Orchestral Concert by the Izar Orchestra. 10.0, Programme of Dance Music. 10.30 (approx.), Close Down.

KALUNDBORG (1,153 metres); 7 kW.—Programme also for Copenhagen (337 metres). 10.0 a.m., Relay from a Church. 11.30 a.m., Weather Report (for Kalundborg only). 2.0, Divine Service. 6.50, Weather Report (for Kalundborg only). 7.0, News Bulletin. 7.15, Time Signal. 7.30, Talk. 8.0, Chimes from the Copenhagen Town Hall. 8.5 (approx.) Musical Programme: Part I, Selections from the Works of Niels W. Gade; Part II, Light Orchestral Music; in the interval Recitations. 11.0, Dance Music Programme; in the Interval at 12 Midnight, Chimes from the Copenhagen Town Hall. 12.30 a.m. (approx.) (Monday), Close Down.

KATOWITZ (422 metres); 10 kW.—10.15 a.m., Divine Service. 12 Noon, News Bulletin. 4.0 Programme of Talks and Music. 8.15, Outside Concert Relay. 10.0, News Bulletin. 10.30, Programme of Dance Music. 11.30, (approx.), Close Down.

KAUNAS (2,000 metres); 7 kW.—12 Noon, Chimes followed by Weather Report. 12.10, Sacred Music Recital. 5.0, Report for Agricultural Workers. 6.0, Variety Selections. 7.30, Health Talk. 8.30, Lowering of the Flag; Ceremony relayed from the War Museum in Kaunas. 9.0, Concert of Trio Music, Songs and Recitations conducted by Mr. Leskovicus. 10.30 (approx.), Close Down.

KIEL (254.2 metres); 0.7 kW.—6.30 a.m., Orchestral Concert, relayed from Berlin. 8.25 a.m., Time Signal, Weather Report, News Bulletin, Commerce Notes and Programme Announcements, relayed from Hamburg. 9.15 a.m., Morning Recital from Hamburg. 10.55 a.m., Divine Service, relayed from the University Church in Kiel. 12.55, Nauen Time Signal. 1.0, Studio Concert from Hamburg. 2.0, Children's Programme, followed by Programme of Talks and Music. 7.40, Sports Notes. 7.55, Weather Forecast. 8.0, Musical Programme, followed by Weather Report, News Bulletin and Concert from the Café Wallhof, in Hamburg. 11.0 (approx.), Close Down.

KÖNIGSBERG (329.7 metres); 4 kW.—Programme relayed by Danzig on 272.7 metres. 9.0 a.m., Morning Recital and Religious Address. 11.0 a.m. (for Königsberg only), Weather Forecast. 11.15 a.m. (approx.), Orchestral Concert, relayed from Danzig. 12.55, International Time Signal from Nauen, followed by Weather Report. 3.0 (approx.), 8.10, Programme of Talks and Music. 8.10, "How our Parents Played and Sang": A Programme of Instrumental Quartet Music with Soprano Solos by Edith Waschke; Tenor Solos by Adolfe Henke, Violin and Pianoforte Selections by Georg Beerwald and Karl Ninke, and a Commentary by Heinz-Herbert Brausewetter, including Old German Songs and Dances. 10.15 (approx.), Weather Forecast, News Bulletin and Sports Notes, followed by Programme of Dance Music. 12.0 Midnight (approx.), Close Down.

LAHTI (1,522.8 metres); 35 kW.—Programme also for Helsingfors (375 metres). 9.0 a.m., Divine Service in the Finnish Language. 10.50 a.m., Popular Orchestral Concert, conducted by Erkki Linko; in the Interval, Recital of Songs. 11.50 a.m., Weather Forecast and Time Signal. 6.10, Orchestral Concert. 7.30, Recital of Finnish Songs by Olli Siikanieni. 7.50, Orchestral Concert (continued). 8.45, Last News Bulletin in the Finnish and Swedish Languages. 9.15, Concert, relayed from a Restaurant. 10.0 (approx.), Close Down.

LANGENBERG (468.8 metres); 20 kW.—Programme also for Aix-la-Chapelle (400 metres), Cologne (283 metres) and Münster (250 metres). 8.45 to 9.45, see Cologne Programme. 9.30 to 10.30, Sacred Morning Recital, relayed from Cologne. 12.30 (approx.), Literary Programme, relayed from Cologne. 2.15 Relay of the Unveiling of the Ebert Erzberger-Kathenau Memorial from Osnabrück. 5.45, see Cologne Programme. 8.0, Evening Variety Programme, followed by Last News Bulletin, Sports Notes and Orchestral Selections, relayed from Cologne. 12.0 Midnight (approx.), Close Down.

LAUSANNE (680 metres); 1.5 kW.—8.30, Sports Notes. 8.40, Protestant Divine Service.

Sunday, July 29th.

All Times are reduced to British
Summer Time and are p.m. except
where otherwise stated.

Programmes from Abroad.—

LEIPZIG (365.8 metres); 4 kW.—8.30 a.m., Organ Recital, relayed from the Leipzig University Church; Organist, Professor Ernst Muller. 11.0 a.m., Relay of an Orchestral Concert from a German Watering Place. 12.0 Noon, to 1.0 p.m., Two Talks arranged by the Hans Bredow School. 1.0 to 2.0, Agricultural Talks. 2.0, Review of the Foreign Press. 2.15, Bulletin of the "Deutscher Sprachverein." 2.30, Concert by the Dresden Wireless Orchestra, relayed from the Jahresschau in Dresden. 6.30, Talk relayed from Berlin. 7.0, Talk. 7.30, Musical and Literary Guessing Competition, Selected from Items given in the programmes of the past week, followed by Orchestral Selections. 10.0, Sports Notes. 10.30, Dance Music by the Gerhard Hoffmann Orchestra, relayed from Berlin. 12.30 a.m. (approx.) (Monday), Close Down.

LILLE, Call PTT (264 metres); 0.5 kW.—12.30, Concert of Orchestral Music, organised by the Association of Radiophonie du Nord de la France. 1.35, Market Prices of Motor Oils. 9.0 (approx.), Programme of Music.

LYONS (Radio-Lyon) (291 metres); 1.5 kW.—11.0 a.m., Instrumental Concert, followed by Recital of Sacred Music. 7.30, "Le Journal Parlé": Weather Report, News Bulletin and Topical Talk, followed by Talk: Sunday in Sport, by M. Paul Garcin and Agricultural Talk by M. Francillon-Chazallet. 8.15, Instrumental Concert. 9.30, Recital of Ancient and Modern Dance Music. 10.30 (approx.), Close Down.

MADRID (Union Radio), Call EAJ7 (375 metres); 3 kW.—2.0, Concert by the Artus Orchestra. 3.30 to 7.0, Interval. 7.0, Children's Corner, Luis Medina, and Music by the Artus Orchestra. 8.0 to 8.30, Dance Music Programme. 10.0, Chimes and Time Signal, followed by Concert by the Municipal Band, conducted by Senor Villa. 12.0 Midnight, Probable Dance Music Programme. 12.30 a.m. (approx.) (Monday), Close Down.

MILAN, Call IMI (526.3 metres); 7 kW.—10.30 to 11.15 a.m., Vocal and Instrumental Concert of Sacred Music. 12.30, Time Signal, followed by Selections by the E.L.A.R. Quartet. 4.0, Concert of Quintet Music and Vocal Selections. 5.30 (approx.), Dance Music Programme, relayed from the Diana Restaurant in Milan. 6.15 to 8.25, Interval. 8.25, Opening Signal, followed by Programme of Talks. 8.35, Time Signal, followed by History Talk by A. Blanche. 8.50, "The Italian in Algiers," Opera (Rossini); Talk and Sports Notes during the Intervals. 11.45 (approx.), Close Down.

MOTALA (1,380 metres); 30 kW.—Programme also for Stockholm (151.5 metres), Boden (1,190 metres), Göteborg (416.5 metres), Malmö (260.9 metres), Östersund (720 metres) and Sundsvall (515.6 metres).—11.0 a.m., Divine Service. 1.20, Relay of the Changing of the Guard at the Royal Castle, with a Military Band Concert. 5.55, Chimes from the Stockholm Town Hall. 6.0, Divine Service, followed by Evening Programme of Literary and Musical Selections. 11.0 (approx.), Close Down.

MUNICH (535.7 metres); 4 kW.—Programme relayed by Augsburg (566 metres), Kaiserlautern (201.1 metres) and Nuremberg (241.9 metres).—11.0 a.m., Relay of Chimes from the Town Hall, Munich. 11.15 a.m., Weather Forecast, followed by Musical Programme. 1.5 (approx.), Weather Forecast, Programme Announcements and Agricultural Talk. 3.0 (approx.) to 8.0, Programme of Talks and Music. 8.0, Instrumental Concert. 9.0, "Everyman," a Mystery Play revised and arranged by Hugo von Hofmannsthal, relayed from Augsburg, followed by Last News Bulletin and Relay of Musical Selections. 12.0 Midnight (approx.), Close Down.

NAPLES, Call INA (333.3 metres); 1.5 kW.—10.9 a.m., Recital of Sacred Music. 4.45, Programme for Children. 5.0, Concert of Instrumental Music. 5.35, Time Signal, followed by Talks. 8.40, Time Signal, followed by Report of the Naples Harbour Authorities. 8.50, Concert of Orchestral and Vocal Selections from Opera; Selections from The Force of Destiny (Verdi) by Raff Aliciano (Baritone). 10.0, Sports Notes. 10.55, Calendar and Programme Announcements for the following Day. 11.0 (approx.), Close Down.

OSLO (461.5 metres); 1.5 kW.—Programme relayed by Fredrikstad (131.8 metres), Hamar (555.6 metres), Notodden (111 metres), Porsgränd (590 metres) and Rjukan (418 metres).—10.20 a.m. (approx.), Chimes, followed by Morning Service. 7.45, Weather Forecast and News Bulletin. 8.0, Time Signal, Talks and Music. 9.30 (approx.), Weather Forecast, News Bulletin and Talk on Topical Events. 10.30 (approx.), Dance Music, relayed from the Hotel Bristol, Oslo. 12.0 Midnight (approx.), Close Down.

PARIS (Ecole Supérieure), Call FPTT (453 metres); 0.5 kW.—Programme relayed at intervals by the following Stations: Bordeaux, PTT (275 metres), Eiffel Tower (2,650 metres), Grenoble (116 metres), Lille, PTT (264 metres), Limoges (286 metres), Lyons, PTT (476 metres), Marseille (303 metres), Rennes (280 metres), Toulouse, PTT (260 metres). 8.0 a.m., News Bulletin and Time Signal. 10.25 a.m., International Time Signal and Weather Forecast. 1.30, Instrumental Concert, including Haydn's Eleventh Symphony. 6.0, "Le Radio-Journal de France." 8.30, Sports Results. 9.0, Instrumental Concert, organised by the Association Générale des Auditeurs de T.S.F., followed by Dance Music Programme, relayed from the Coliseum de Paris. 12.0 Midnight (approx.), Close Down.

PARIS (Eiffel Tower), Call FL (2,650 metres); 5 kW.—8.56 a.m., Time Signal on 32.5 metres. 10.25 a.m., Time Signal on 2,650 metres. 6.45, "Le Journal Parlé," par T.S.F., Talks on Health, Police Anecdotes, Race Notes, etc., with Talks by M. Julien Maigret, Marc Frayssinet, Jean Volvey, Mme. Paule Héllès and other regular contributors. 8.10, Weather Forecast. 8.30, Concert by Mario Cazes and his Orchestra. 8.56, Time Signal on 32.5 metres. 11.28, Time Signal on 2,650 metres.

PARIS (Petit Parisien) (340.9 metres); 0.5 kW.—8.45, Gramophone Records, Talk and Press News. 9.0, Instrumental Selections. 9.25, News Bulletin. 9.30, Symphony Concert: First Part of the Second Symphony in D Major: The Ocean Symphony (Rubinstein). 10.0, News Bulletin, followed by Instrumental Music.

PARIS (Radio L.L.) (370 and 60 metres); 1 kW.—3.0, Concert of Dance Music, arranged by Les Etablissements Radio L.L. 9.0, Vocal and Instrumental Concert. 10.30 (approx.), Close Down.

PARIS (Radio-Paris), Call CFR (1,750 metres); 6 kW.—8.0 a.m., Review of the Press. 12.0 Noon, Religious Address by the Reverend Father Pade, followed by Selections of Instrumental and Choral Sacred Music. 12.40 (approx.), News Bulletin. 12.45, Selections by the Albert Locatelli Orchestra with Bilboquet in his Variety Repertoire. 4.30, The Grand Vatel Dance Orchestra, News Bulletin in the Interval. 8.0 (approx.), Agricultural Talk and News Bulletin. 8.30, Orchestral and Solo Concert, with Beethoven's Sonata in D Major, played by M. Pierre Lucas; in the Intervals, News Bulletin.

PITTSBURGH, Call KDKA (63 and 27 metres); 25 kW.—3.45, Telechron Time Signal. 4.0, Divine Service. 7.0, Roxy's Stroll, Variety Programme, relayed from New York. 9.0, Telechron Time Signal, followed by Dr. Sockman's Question Hour from WJZ, New York. 11.0, Telechron Time Signal, followed by Baseball Scores. 11.30, Orchestral Concert by the KDKA Ensemble, conducted by Victor Saudek, relayed from the Palm Room of the William Penn Hotel, Pittsburgh. 12.0 Midnight, Telechron Time, followed by Continuation of KDKA Ensemble Concert. 1.0 a.m. (Monday), High Spots of Melody Programme, relayed from WJZ, New York. 1.45 a.m., Whittall Anglo-Persians, relayed from WJZ. 2.15 a.m., Concert by the Goldman Band from WJZ. Longtime Time. 3.15 a.m., Baseball Scores and Telechron Time Signal. 3.30 a.m. (approx.), Close Down.

POJEN (344.8 metres); 1.5 kW.—10.15 to 11.45 a.m., Morning Service relayed from a Cathedral. 12.0 Noon, Two Agricultural Talks. 12.50, Bulletin of the League of Youth. 5.0, Programme relayed from Warsaw. 6.50 (approx.), Talk relayed from Warsaw. 7.15, Talk: Silva rerum by Mr. B. Busiakiewicz. 7.45, Talk relayed from Warsaw. 8.30, Concert, featuring Mme. Sophie Fedyczkowska (Soprano) and Mr. Kajetan Kopczyński (Baritone). 10.0, Time Signal, News Bulletin, Weather Forecast and Sports Notes. 10.20 (approx.), Variety Selections, followed by relay of Dance Music. 12.0 Midnight (approx.), Close Down.

PRAGUE (348.9 metres); 5 kW.—10.0 a.m., Concert of Sacred Music, followed by Light Musical Selections. 12.0 Noon, Orchestral Concert. 1.5, Industry and Trade Notes, followed by Musical Selections. 7.0 (approx.), Musical Programme. 10.0, Time Signal and News Bulletin, followed by Programme, relayed from Brno. 11.0 (approx.), Close Down.

ROME, Call IRO (450 metres); 3 kW.—10.15 a.m., Opening Signal, followed by Sacred Concert of Vocal and Instrumental Music. 1.15, Station Trio Concert. 2.15, News Bulletin, followed by Interval. 5.0, Opening Signal. 5.2 (approx.), Studio Concert. 6.0 to 6.30, Programme of Dance Music, relayed from the Casinetta, Rome. 8.0, Opening Signal, followed by Talks. 8.20, Forestry Notes. 8.30, Sports Notes and News Bulletin. 8.59, Time Signal. 9.0, Instrumental Concert, with Pianoforte Solos from the Works of Debussy and Liszt, by Renato Josi. 11.5, Last News Bulletin. 11.15 (approx.), Close Down.

SCHENECTADY, Call 2XAD and 2XAF (21.96 and 31.4 metres); 30 kW.—3.30, Divine Service of the Albany Street M.E. Church, Address by the Rev. Cassius J. Miller. 10.30, Concert by the Ballad Singers, New York. 11.0, Stetson Parade, American Legion Band (Boston). 12.0 Midnight, Pianoforte Recital by Hans Barth, relayed from New York. 12.25 a.m. (Monday), Baseball Scores from New York. 12.30 a.m., Capitol Theatre Programme from New York. 2.0 a.m., Talk on the United States Government, from Washington D.C. 2.15 a.m., Atwater Kent Programme, from New York. 2.45 a.m., Correct Time, followed by Biblical Drama from New York. 3.15 a.m., Television Signals on 379.5 metres (Experimental Transmission). 3.30 a.m. (approx.), Close Down.

STAMBOUL (1,200 metres); 5 kW.—4.30, Orchestral Concert. 5.30, Market Prices. 6.15, Concert of Turkish Music. 8.30 (approx.), Weather Forecast and Time Signal. 8.40, Instrumental Concert. 10.0, News Bulletin. 10.30 (approx.), Close Down.

STETTIN (236 metres); 0.75 kW.—6.30 to 9.0 a.m., Instrumental and Vocal Music, relayed from Voxhaus. 11.30 a.m. to 12.0 Midnight, Programme of Talks, Orchestral, Vocal and Dance Music, relayed from Voxhaus.

STUTTART (379.7 metres); 4 kW.—11.0 a.m. (approx.), Morning Recital, followed by Concert relayed from the Castle Square in Stuttgart, and Gramophone Record Selections. 2.0, Programme for Children, relayed from Voxhaus, followed by Talks. 4.0 (approx.), Instrumental and Vocal Concert. 6.0, Time Signal and Sports Notes, followed by Light Dramatic and Musical Programme; News Bulletin.

TOULOUSE (Radiophonie du Midi) (391 metres); 3 kW.—12.30, Concert of Instrumental Music. 1.0, Time Signal, Chimes. 1.45, Review of the Press. News. 8.0, News Bulletin. 8.30, Instrumental Concert: Part I, Selections from Mascarade (Lacôme), (a) Cortège, (b) Arlequin et Colombine, (c) Les Mandolinistes, (d) Finale; Part II, Schubert Centenary Celebration, Selections from the Works of Schubert; Part III, Popular American and English Dance-Songs. 10.15, North African News. 10.30 (approx.) Close Down.

VIENNA (577 and 517.2 metres); 1.5 and 5 kW.—Programme, relayed by Innsbruck (294.1 metres), Klagenfurt (272.7 metres), and Linz (254.2 metres). 11.0 a.m., Vienna Symphony Orchestra Selections. 4.0, Orchestral Concert, followed by Talk and Chamber Music Programme. 7.45, Programme of One-act Plays from the Cycle "Das Reifenspringen," by Julian Landau, (a) Der lila Handschuh, (b) Die Aussprache, and (c) Tobby, a Grottesque Sketch by Kurt Goetz.

VILNA (435 metres); 1.5 kW.—10.15 a.m., Divine Service, relayed from a Polish Cathedral. 12.0 Noon, Programme, relayed from Warsaw. Time Signal and News Bulletin. 6.30, News Bulletin and Programme from Warsaw; in the Interval, Talk in the Lithuanian Language by J. Kraunajtis. 11.30 (approx.), Close Down.

WARSAW (1,111 metres); 10 kW.—10.15 to 11.45 a.m., Programme, relayed from a Cathedral. 12.0 Noon, Time Signal, Fanfare, relayed from the Tower of the Church of Notre Dame in Cracow, Aviation Report and Weather Forecast. 12.10 to 3.35, No Transmission. 3.35, Weather Forecast. 4.0, Three Talks for Farmers. 5.0, Popular Concert by the Philharmonie de Varsovie Orchestra, relayed from the Dolina Szwajcarska, organised by the Department for Public Instruction in Warsaw.—Orchestral and Solo Selections. 6.30, Variety Items. 6.50, Professor L. Kulczycki: Talk on the History of the Revolutionary Movements in Russia. 7.15 to 7.45, No Transmission. 7.45, Talk. 8.15, Concert by the Philharmonie de Varsovie, organised by the Warsaw Broadcasting Station Authorities; Songs and Orchestral Music with Recitations and Solos from the Works of Chopin. 10.0, Time Signal, Aviation Report and Weather Forecast. 10.5, News, Police Information and Sports Notes. 10.30, Dance Music, relayed from the Oaza Restaurant in Warsaw. 11.30 (approx.), Close Down.

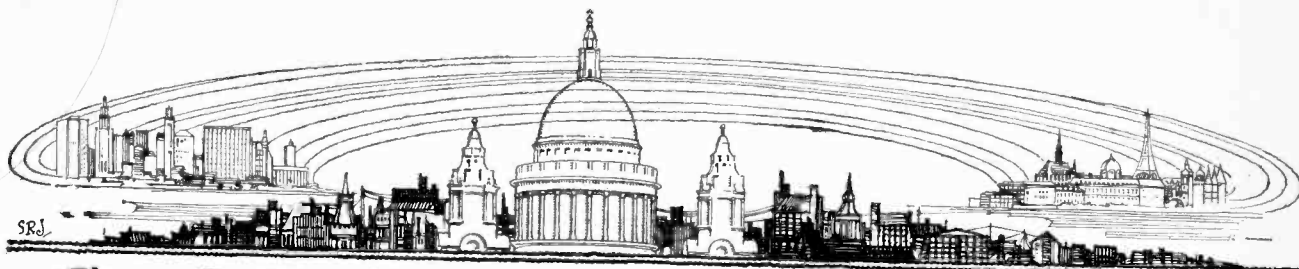

CURRENT TOPICS

Events of the Week in Brief Review.

SPANISH HONOUR FOR MARCONI.

The Spanish Government has bestowed on Senatore Marconi the Plus Ultra gold medal, a high order of civil merit.

o o o o

ROYAL LISTENERS.

A new multi-valve broadcast receiver has been installed at Balmoral Castle in preparation for the approaching visit of the King and Queen.

o o o o

AUGUST BANK HOLIDAY.

Owing to August Bank Holiday, the August 8th issue of *The Wireless World* will be closed for press earlier than usual. Miscellaneous advertisements for insertion in that issue can be accepted up to first post on Wednesday, August 1st.

o o o o

B.B.C. AND INDIAN BROADCASTING.

Technical co-operation with the Indian Broadcasting Company has been agreed to by the B.B.C. As a preliminary step it has been decided to relay the London programme from 5SW once a fortnight at a time specially suited to the needs of Indian listeners.

o o o o

SHORT WAVES FROM AFRICAN WILDS.

Listeners on the short waves will soon have an opportunity of picking up signals on 30 metres from a small camp pitched in the wilds of Africa. Major and Mrs. Court-Treant, already well known for their pioneer motor trip from the Cape to Cairo, have gone out to one of the least known parts of the Western Sudan, where they are making two films for British Instructional Films, Ltd. News has just been received from the party that they have now arrived at their "location," a tract of 60,000 square miles of practically uninhabited country.

Amongst their camp equipment is a specially designed Marconi transmitting set, the power for which is supplied by a hand generator. Starting in about a week's time, Major Court-Treant will transmit every Sunday evening between the hours of 6 p.m. and 8.30 p.m. (Greenwich Mean Time). His call will be FXCT, and the wavelength 30 metres (approximately).

A 27

LACKING DIGNITY.

The U.S. Commissioner of Patents recently denied an application for a patent on a variable condenser with plates shaped to give a straight-line frequency effect, on the ground that it "lacked the dignity of an invention." The decision was sustained by the Supreme Court.

WIRELESS LECTURE IN ESPERANTO.

At the twentieth Universal Esperanto Congress, to be held in Antwerp from August 3rd to 11th next, Professor R. Memy, Director of the National Laboratory of Radio Electricity in Paris, will deliver a lecture in Esperanto on "The Applications of Wireless in Navigation."

o o o o

WIRELESS "LIGHTHOUSES."

Seven coastal beacon transmitters are now under construction by the Marconi Company. They will be installed at Start Point, Lundy Island, Sale Skerry, Dungeness, South Bishop, Kinnaird Head, and Cromer. Beacons are also projected for Tory Island and Mizen Head.

o o o o

LEAGUE OF NATIONS WIRELESS.

A committee appointed by the League of Nations has recommended the acceptance of a proposal by Radio-Suisse to construct a wireless telegraphic station in the Canton of Geneva for the exclusive use of the League in times of crisis. Radio-Suisse is a commercial organisation in which the Swiss Government is largely interested.

o o o o

DO BROADCAST ADVERTISEMENTS PAY?

A somewhat startling discovery, striking at the foundations of the present system of broadcasting in America, has been made by the John Wanamaker store, who were the pioneer broadcasters in Philadelphia. "Investigations made by a special inquiry among radio listeners during the past two years," runs a statement by that firm, "have revealed that broadcasting is not helping the store in general or in an advertising way." The Corporation has accordingly closed down broadcasting station WOO, Philadelphia, which has been "on the air" ever since 1922, and it is extremely unlikely that WOO will ever be heard again.

The opinion appears to be growing that many other broadcasting interests would reach similar conclusions if they carried out investigations. The American public may well hope that the question will be allowed to drop, for practically all their broadcast entertainment is provided by firms seeking advertisement.



TAKING BEARINGS. Members of the Golders Green and Hendon Radio Society photographed at King's Langley on Sunday, July 15th, while tracking a concealed transmitter.

LOUD SPEAKER POINTS ON NEW STEAMER.

Broadcast receiving equipment for the entertainment of passengers will be one of the luxuries on board the *Lady Nelson*, the twin-screw steamer launched at Birkenhead last week for the Canadian National Steamships' service between Canada and the West Indies. Leads will be provided in all public rooms on the ship, so that loud speakers can be plugged in as desired.

AN AMALGAMATION.

Those of our readers who are photographers will be interested to learn that, commencing with the issue of August 1st, our sister journal, *The Amateur Photographer*, and its contemporary, *The New Photographer*, will be merged into one publication. The combined journal, which will be known as *The Amateur Photographer incorporating The New Photographer*, will continue to be published from these offices every Wednesday, price 3d., and obtainable from newsagents, bookstalls, and leading photographic dealers. All the features of the two journals which have proved most attractive to readers in the past will be embodied in the combined paper, and every effort will be made to make the one weekly journal more and more interesting and valuable to amateur photographers in the practice of their hobby.

o o o o

SUBSTANTIAL MARCONI PROFITS.

Marconi's Wireless Telegraph Co., Ltd., have declared a profit of £430,471 for the year 1927, as compared with £198,948 in 1926. The directors are making an interim distribution of 10 per cent. less tax, while a final dividend is to be considered later.

POLITICAL BROADCASTING SCRAMBLE
IN U.S.

The steady rise in the political temperature of the United States as the Presidential election draws nearer is finding expression in the growing use of broadcasting by both the Democratic and



UNDER COVER. The mobile transmitter and operators "lent" by 47th Divisional Signal Co. (Territorial Force) to the Golders Green Society on their recent field day. The transmitter was concealed at Elstree.

Republican parties. It cost 104,000 dollars to broadcast the recent Democratic Convention, according to the National Broadcasting Company, or 27,000 dollars in excess of the amount spent on the Republican Convention.

No doubt the Republicans will soon adjust matters to their advantage. The Democrats will then reply, and before the election date in November there will probably be a battle royal between the parties to secure the maximum amount of microphone publicity.

o o o o

IRISH TRANSMITTERS.

The Irish Radio Transmitters' Society early last month held a "Conference on the Air" to test the suitability of the various transmitting circuits used by their members. The result of these tests was so encouraging that the I.R.T.S. is now making arrangements for a similar general test at an early date, but this time it is to be confined to telephony only and to experimenters living in or near Dublin; we also understand that non-members are asked to participate. Full particulars have not yet reached us, but those wishing to take part should communicate with the Hon. Secretary, Mr. D. G. Kennedy (GW 14C), 21, Morehampton Road, Dublin.

USEFUL DATA CHARTS. (No. 3.)

Inductance, Capacity, and Frequency: Medium-wave Band.

This abac is designed chiefly for use over the broadcast band from 550 to 200 metres. If we neglect stray capacities we can find the size of coil required with a 0.0003 mfd. condenser by laying a ruler across 0.0003 and 550 metres, which gives us 284 microhenrys. Then, on joining 284 microhenrys to 200 metres, we find that the condenser must be nearly all out at a value of 0.00004 mfd. We should be able to get down to this value, since any good make of condenser has its maximum capacity about ten times its minimum.

In some sets the aerial is joined directly to the top of the grid coil, thus introducing an extra capacity of about 0.00015 mfd. in parallel with the grid tuning condenser. The abac shows at once the evil effect produced. Instead of a capacity range of 0.0003 to 0.00004 we now have 0.00045 to 0.00018. Join 0.00045 to 550 metres and we read off 189 microhenrys. Then join 189 microhenrys to our minimum capacity of 0.00018 mfd., and the minimum wavelength is found to be 348 metres, and so we cannot possibly tune over the whole broadcast band. It is much better to have a loose-coupled aerial or to include only about one-fifth of the coil turns between aerial and earth, in which case the added capacity is so small that the full range can be obtained.

When a tuned plate circuit is used for H.F. amplification, no trouble should arise from stray capacities. The grid-plate capacity of the valve will never exceed 10 micro-microfarads, and the equivalent parallel capacity of the grid-leak and condenser which joins on to the detector is a fraction of a micro-microfarad.

Advantages of Logarithmic Scales.

When we use a linear scale such as a foot rule the seriousness of any error in estimating a length depends very much on what part of the scale is being used. If we are liable to be in error by $\frac{1}{10}$ in. we shall be wrong by 10 per cent. in measuring one inch, but the same inaccuracy in measuring 10 inches will give rise to a percentage error of only 1 per cent.; accordingly we cannot measure small distances with the same confidence as large ones.

Now, a remarkable property of the logarithmic scale is that the percentage error is the same all along the scale. Reference to the abac will show the distances between 10 and 11, 20 and 22, 50 and 55, 100 and 110, are all equal, and accordingly the error amounting to 10 per cent. involved in going wrong by this distance is equally likely to occur at any part of the scale. [It is understood, of course, that anyone who *does* go wrong by such a large amount is in need of an immediate holiday.]

Thus the logarithmic scale gives a large range of numbers in a small compass. This week we have a scale of metres ranging from 60 to 1,000, and we should be able to read any wavelength to a half of 1 per cent. If the same range had been marked out on a linear scale the lower third of the scale would have been almost useless. In a future abac we shall be obliged to use linear scales for finding the resultant of two resistances in parallel or of two condensers in series, but in that case we have to bow to necessity; there is no other simple way of constructing the abac.

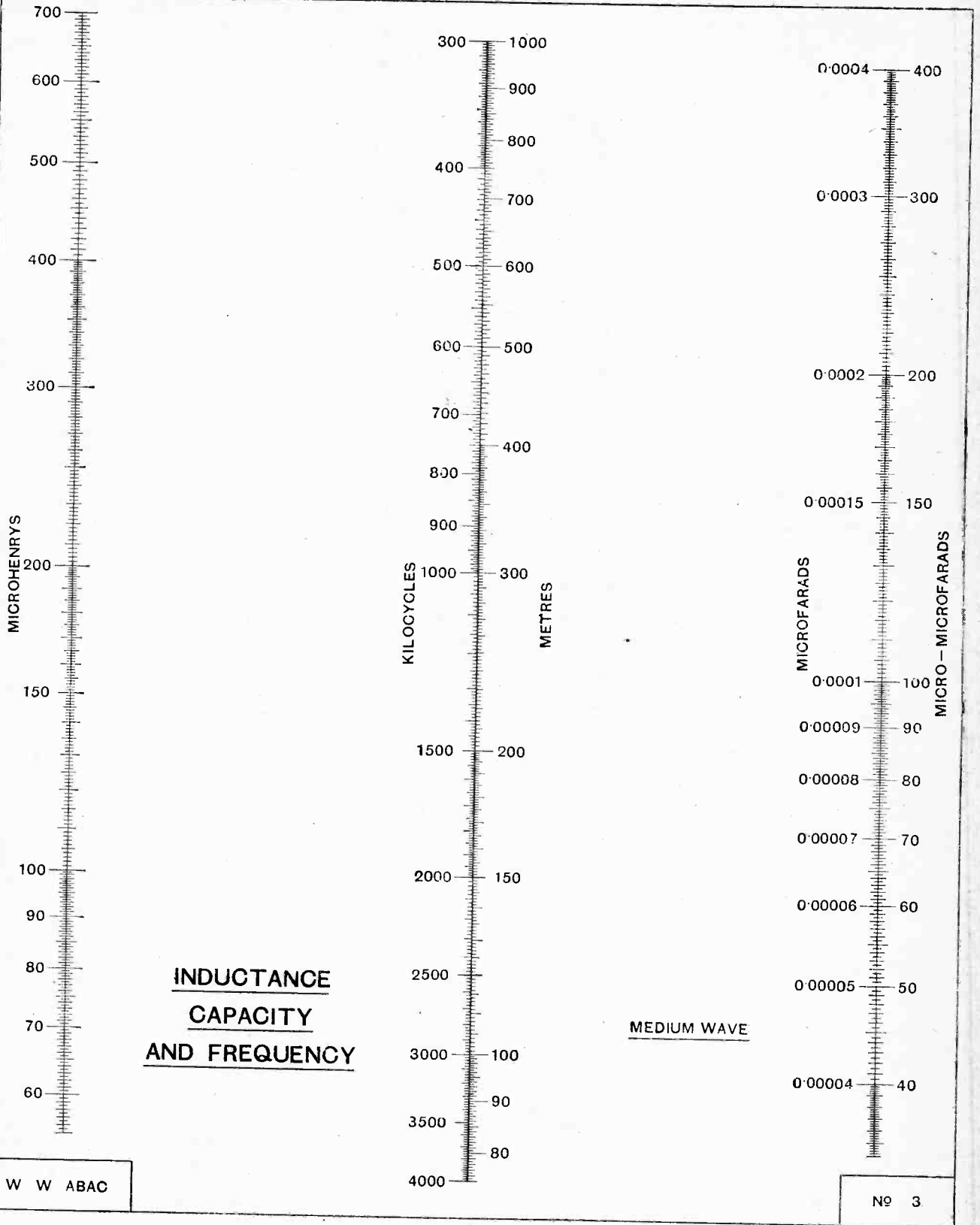



A Review of the Latest Products of the Manufacturers.

GRAHAM-FARISH GRID LEAK BASE.

The brown bakelite base of this grid leak holder is reinforced with ribs extending from the central screw hole and is of exceptional strength. The nickelled spring clips are slotted and fitted with

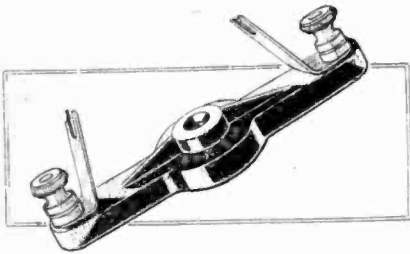

Graham Farish grid leak base with centre screw fixing.

large terminals, and will accommodate all standard grid leaks, as well as those types which are fitted with terminal end caps. The price of this component, which is made by The Graham-Farish Co., 17, Masons Hill, Bromley, Kent, is 6d.

BURNDIPT WANDER PLUGS.

These plugs are of the rigid type and reliance is placed on spiral fluting for obtaining a grip on the walls of the battery sockets. The overall length has been kept small and the size of the battery compartment can be correspondingly reduced where these plugs are used. Each



Burndipt wander plug.

plug is fitted with an insulating ring of distinctive colour. There are seven colours to choose from and the plugs cost 2s. 6d. per dozen. The hole for fixing the wire is readily accessible and a steel set screw fitting vertical in the top of the plug is used to clamp the wire.

THE LORIODAPTER.

Made by A. W. Stapleton, 19a, Lorrimore Buildings, Lorrimore Street, London, S.E.17, this component is designed to fit the standard electric light socket for the purpose of charging accumulators from the lighting circuit. When charging L.T. batteries the diminution in light is negligible and if charging is undertaken at night time when the lamp would be used in any case, the cost of charging can be regarded as nil. With H.T.

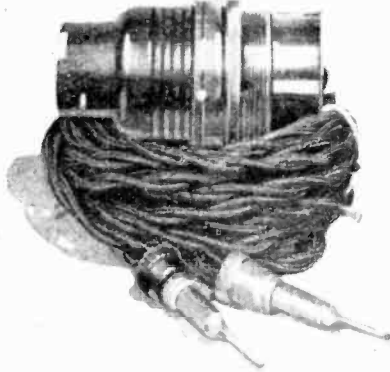

Loriodapter for charging H.T. and L.T. accumulators from the lighting circuit.

accumulators, on the other hand, the back E.M.F. caused will considerably reduce illumination unless the sections of the battery are paralleled, but this is not to be recommended as there is a possibility that one section may discharge through the others when the current is switched off. Before connecting up it is essential to test the polarity of the leads and reverse the plug in its socket if necessary.

CLIX ACCUMULATOR KNOBS.

Trouble from acid corrosion is minimised in this terminal knob by an annular grease-retaining groove surrounding the metal insert. The brass insert is tapped to fit the standard accumulator thread and is keyed on the outside to prevent

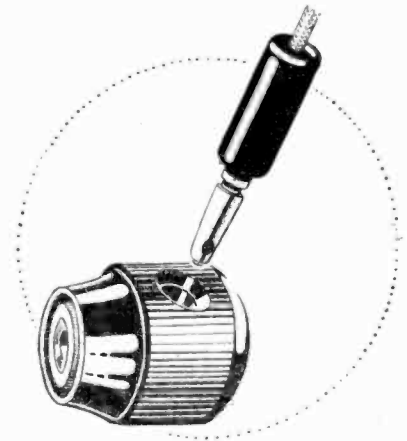

Clix acidproof accumulator knob.

it turning in the outer moulding. The moulded bakelite shroud is fluted and may be had in black or red material. Each knob is drilled laterally to take the "Clix-Lox" plug described on page 698 of the June 27th issue thus ensuring a firm and yet easily detachable connection for the L.T. leads. The moulded knob is recessed to fit the Clix-Lox sleeve to prevent the ingress of acid spray. Costs 5d. and is well up to the standard of the products of Lectro Linx, Ltd., 254, Vauxhall Bridge Road, London, S.W.1.

"ACONICAB" CABINETS.

Cabinets are made under this trade name by A. V. Clarke, 22, Old Montague Street, London, E.1. The type illustrated costs 25s. in mahogany, and is suitable for the "Everymar Four," the dimensions being 26in. x 8in. x 8in. The quality and finish are excellent.

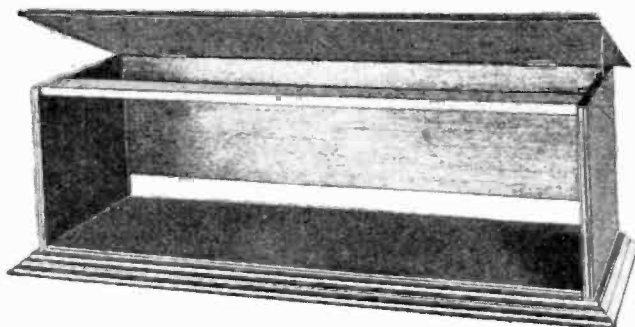

"Aconicab" mahogany cabinet.

THE OUTPUT STAGE AND THE PENTODE.

Operating Conditions and Circuit Systems.

PART III.

(Concluded from page 80 of previous issue.)

By N. W. McLACHLAN, D.Sc., M.I.E.E.

IN dealing with triodes we are familiar with the "equivalent" diagram shown in Fig. 15. Here is replaced the triode by a fictitious alternator whose voltage is $m \times$ volts on grid = mV_g . A resistance ρ equal to the valve resistance is connected in series with the alternator, and to this is added the impedance or load, e.g., a loud speaker. Now this diagram can be applied to the pentode. In Fig. 15 we have a case in point. The value of $m = 60$, signal volts 7.5, $\rho = 33,000$ ohms, and the loud speaker impedance is substantially negligible. The maximum value of the current in the anode circuit of the valve is

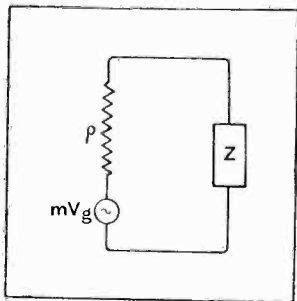

Fig. 15.—Diagram illustrating the equivalent circuit of a valve. mV_g = voltage of fictitious alternator, ρ = internal resistance of valve, Z = impedance in valve circuit, e.g., the loud-speaker. The current is $\frac{\text{voltage}}{\text{total impedance of circuit}}$ or $\frac{mV_g}{\text{vector sum of } \rho \text{ and } Z}$.

by Ohms Law $i = \frac{\text{volts}}{\text{ohms}} = \frac{60 \times 7.5}{33,000} = 0.013$ ampere = 13 milliamperes (see Fig. 16). Although the internal valve resistance is high, so also is the voltage of our fictitious alternator by virtue of the high magnification factor. Writing the

above result symbolically for a signal voltage of unity [I] we get the current $i = \frac{m}{\rho} \times 1 = \frac{m}{\rho}$, which we know to be the conductance g . Thus we see that, provided there is a large anode current and a relatively long grid swing available, the variation in the former depends on the conductance. For meritorious performance the conductance should be high, and this is precisely where the pentode scores over the triode.

It may be useful to compare the relative possibilities of the pentode with the triode. First of all, let us use our 1,000-turn coil. Then from the circuit of Fig. 15 we have current = $\frac{\text{voltage}}{\text{total impedance}} = \frac{mV_g}{Z + \rho}$, Z and ρ being added vectorially. Using the pentode, Z is negligible, so that the current = $\frac{m}{\rho} V_g = g V_g = 1.8 \times 10^{-3} V_g$.

For the triode the internal resistance is low (2,700 ohms for LS5A), so that the coil impedance must be taken into account. Z is therefore the vector sum of 2,700 and the coil impedance. At 4,000 cycles Z is about 5,500 ohms. Consequently current = $\frac{mV_g}{Z} = \frac{2.2 \times V_g}{5,500} = V_g \times 4 \times 10^{-4}$. The ratio of the currents with pentode

and triode is, therefore, $\frac{1.8 \times 10^{-3}}{4 \times 10^{-4}} = \frac{18}{4} = 4.5/1$. Put in another way, for equal output with the two valves, the signal voltage to the pentode is 1/4.5 that to the triode. By using a coil of 2,500 turns with the pentode and 1,000 turns with the triode, this ratio becomes approximately 1/9. If an intermediate stage is used between detector and pentode, it is only required to amplify 1/4.5 or 1/9 of the extent required for a triode. In this respect care should be taken to avoid under-loading an anode-bend detector, since there is likelihood of distortion. It is preferable, therefore, for quality to raise the H.F. amplification and place the pentode next to the detector. The comparatively low value of H.T. required is a good feature, but there is, of course, a large anode feed current to which must be added 20 per cent. for the screen. If push-pull is employed with valves biased half way along the curved portion² the consumption can be curtailed considerably. For those who use

¹ It is not 4.5×2.5 , since the coil impedance reduces the current.

² See *Wireless World*, June 13th 1928.

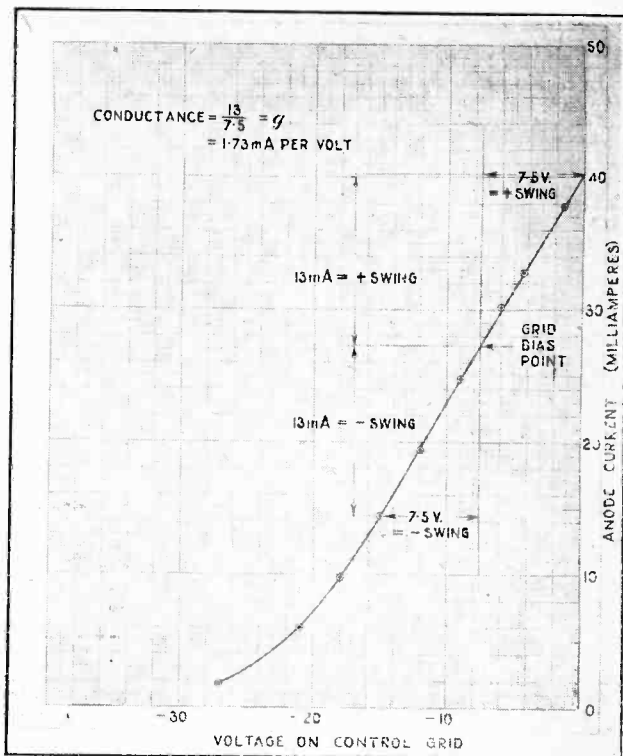

Fig. 16.—Graph indicating variation of anode current with grid voltage for the P.M.22.

The Output Stage and the Pentode.—

the electric light mains the large current supply is immaterial. I feel sure the average person will be able to make enough noise with 150 volts H.T. and a 2,500-turn coil³ to satisfy his aural cravings in a room of average size. Finally, if we have a pentode capable of withstanding 350 volts H.T., and if we use two of these valves back-to-back with a suitable moving coil, the output should be adequate to administer to the most dia-

obtain the correct feed through a resistance of, say, 100,000 ohms would require something of the order of 1,000 volts. If a transformer is used, care must be exercised to avoid saturation of the core. In any case, for proper amplification of high and low frequencies the internal valve resistance is too large for use with a transformer. Thus for high quality the pentode must be relegated to the output stage.

No reliable information regarding the electrostatic anode to grid capacity of the tetrode is available, but data—even if 30 per cent. in error—on this point will be welcome. Perhaps the manufacturers will be so good as to make a statement concerning the order of the capacity of the pentode *per se*. It is realised that leads, etc., will modify the result, but that is the experimenter's funeral.

A good deal more could be said about this new valve, but I hope that its salient features have been presented in such a manner that the reader will handle it skilfully when it appears in the flesh. I trust that the manufacturers will see their way to adding an additional terminal for the low-potential grid. Access to this electrode opens up other possibilities. Also it would be useful, in view of the connection of the auxiliary grid to the cathode, to know which end of the filament should be made negative.

Battery Coupling.

In any type of receiver it is imperative to reduce any form of stray coupling to a minimum. During the development of broadcast apparatus in the past five years, various forms of unwanted coupling have forced themselves to our notice. There is magnetic and electrostatic coupling between coils and wiring, electrostatic coupling between valve grid and anode, and also battery or H.T. supply coupling. The first type is rendered *hors de combat* by a metallic screen and by scientific wiring. The second has been reduced very materially by placing an internal screen between grid and anode. The third has just come into the limelight in view of increased ampli-

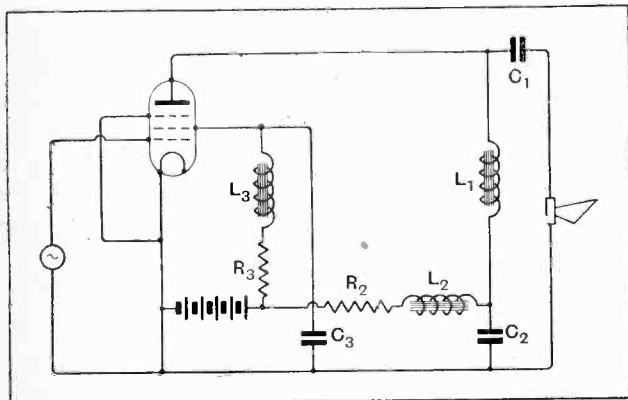

Fig. 17.—Battery "auto-coupling" circuits for the pentode. $C_1, C_2, C_3=2$ to 4 mfd. R_2, R_3 =resistance to give correct value of anode voltage. L_1, L_2, L_3 =chokes of 20 henrys or more. The use of L_2 is perhaps a refinement, but is advisable where there is an intermediate audio frequency stage between detector and pentode.

bolical taste, e.g., those who like to simulate a full-blown orchestra in 1,000 cubic feet of space.

Although the pentode is primarily a loud speaker valve, there seems to be no reason why it should not function as a grid leak detector. The next stage cannot be resistance-coupled owing to the large anode feed. To

³ In making this statement I assume the flux in the air gap to be not less than 8,000 lines per square cm. This requires a soft steel casting.

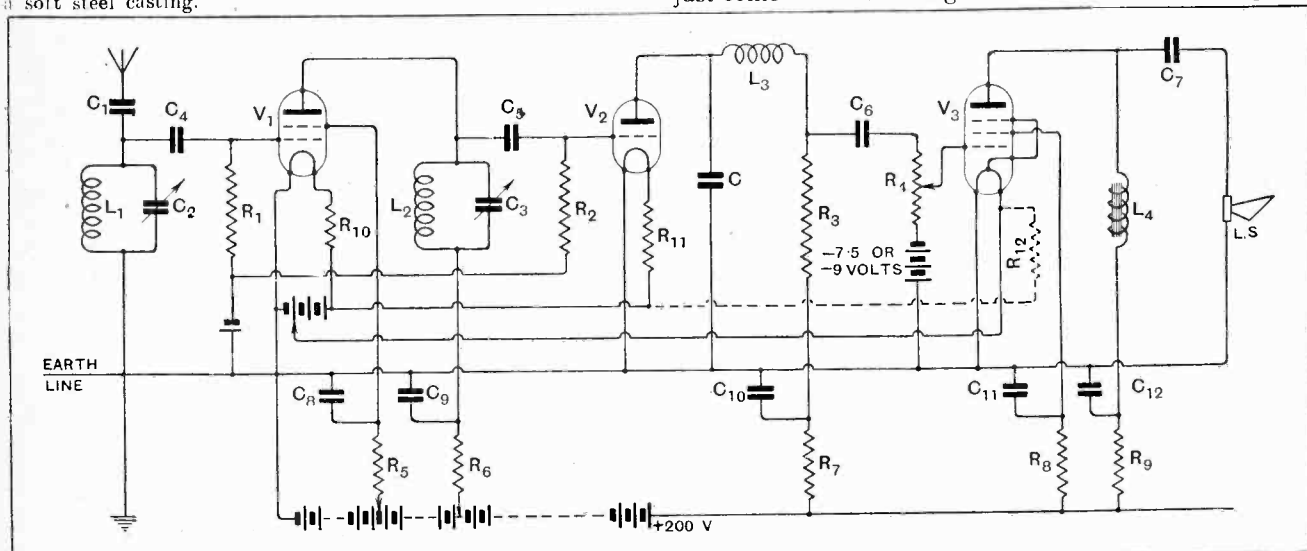

Fig. 18.—Diagram of high-quality receiver with pentode output stage. $C=0.0002 \mu F$, $C_1=0.0002 \mu F$, $C_2, C_3=0.0005 \mu F$, $C_4=0.002 \mu F$, $C_5=0.002 \mu F$, $C_6=.02 \mu F$, $C_7=4 \mu F$, $C_8, C_9, C_{10}, C_{11}, C_{12}=2 \mu F$. L_1, L_2 =Dubilier Toroids (Red), L_3 =R.F.C., L_4 =Marconi phone Power Choke, 50 henrys, 500 ohms, $R_1=0.25$ megohms, $R_2=0.25$ or 0.5 megohms, $R_3=0.1$ or 0.25 megohms, $R_4=6 \times 0.5 M\Omega$ (Tappings at each 0.5 M Ω), $R_5, R_6, R_7, R_8=10,000$ ohms, $R_9=2,000$ ohms, $R_{10}=2.5$ ohms, $R_{11}=5$ ohms, $R_{12}=13$ ohms. L.S.=Coil-drive speaker with coil of 2,500 turns. V_1 =Screened Valve S625, V_2 =Detector DEH610, V_3 =Mullard Pentode P.M.22, with 2-volt tap from battery or 13 ohms fixed resistance on 6 volts. For voltages on the grid of V_3 greater than 4, V_2 must have another "T" cell for grid bias. This is due to the low modulation factor which limits the audio amplification of V_2 from 3 to 5.

The Output Stage and the Pentode.—

ation, more critical requirements for loud speaker reproduction, and the use of so-called battery eliminators. The elimination of battery coupling is quite ancient, and has been in vogue for land-line repeater work for some eight or ten years. In a repeater system the valves are worked from a common battery supply. Moreover, with, say, a dozen different repeaters at a single station, some artifice is required to prevent intercoupling due to the resistance of the battery. *The golden rule is that no alternating current shall be allowed to pass through the battery.*

Now the A.C. is greatest in the power stage if a receiver, so that particular care must be exercised here in the choice of battery anti-coupling devices. With a power triode the usual procedure is to employ a choke

and condenser filter circuit so that the bulk of the A.C. passes through the loud speaker to earth, thereby dodging the battery. In the pentode we have to cope with two sets of A.C. : (a) that to the anode, (b) that to the screen. Case (a) is treated *à la* triode, whilst case (b) can be treated as illustrated diagrammatically in Fig. 17. Where the pentode is run from the mains, and it is desired to reduce the voltage from 240 to 150, suitable resistances R_2, R_3 can be joined in series with the chokes. Appropriate values can be calculated, using the pentode characteristics which show the valve currents for various values of H.T. and grid bias. Alternatively, a milliammeter can be used to measure the feed and the volts drop on the resistance calculated immediately, thus allowing the correct value for the valve to be found experimentally.

THE PENTODE QUALITY THREE.

Practical Details of Receiver Design with Screened Grid H.F. Valve and Pentode.

The tests on the pentode cited in Part II refer deliberately to a case which is likely to occur in practice. Every experimenter's receiver has one stage of low-frequency amplification. The receiver employed during the

desirable to reduce capacity effects and feed-back effects to a minimum. Accordingly I have designed a high-quality receiver to work on the local station (2LO) or 5GB and 5XX up to distances of 60 to 100 miles or more, according to conditions and requirements.

A diagram of the receiver is given in Fig. 18, whilst the

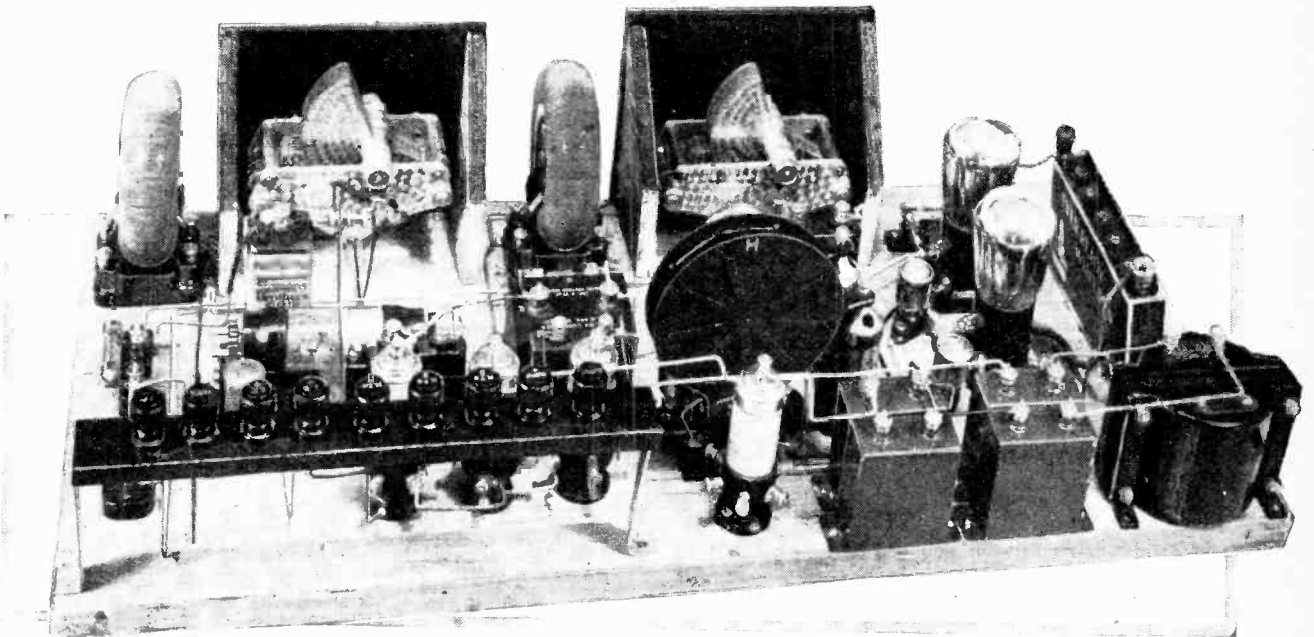

The Pentode Quality Three. A general view of the receiver employing a Pentode output stage: the screen over the left-hand condenser has been removed. The base board is 12in. x 21in.

tests in question has four valves, namely, S625 (H.F.), DEH.610 (detector), LS5, followed by a transformer of high primary inductance, and finally a power triode (LS5A). All the valves are supplied by means of a filter system from a 200-volt battery. The quality from a coil drive with 1,000-turn 2in. diameter coil is highly satisfactory (so far as loud speakers go). The LS5A was replaced by a pentode, and additional resistances added to reduce the H.T. to 150 volts, whilst by-pass condensers were connected from the outer ends of the resistance to earth. The results with the pentode and coil drive were good, but I felt that it was

real thing, *made in a few hours*, is also shown. In Fig. 18 the receiver can be divided into two main sections: (a) the part which works, (b) the part which supplies the energy. An open aerial with coil and condenser is connected via grid leak and coupling condenser to the filament and control grid of an S625 valve. The leak and condenser make it possible to get a nice fit between the earth connection and the bias battery. The latter is a 1.5-volt Siemens "T" cell, and is common to the first two valves. To be able to fully load a pentode an additional bias cell must be used on the detector, i.e., a grid bias of -3 volts. The S625 is operated as an

The Output Stage and the Pentode.—

H.F. amplifier with tuned anode. Both aerial and anode coils are short-wave Dubilier toroids (red, for 5XX blue), spaced gin. apart and separated by condenser C_2 with an earthed cover which screens the coils from each other and also screens C_2 . The coils have a resistance adequate to prevent spurious oscillation due to feed-back in the S625. If oscillation should occur, it is a simple matter to reduce the values of the grid leaks, thereby enhancing the damping. In fact, where signal strength is ample, the grid leaks should be reduced to flatten the tuning, thereby enhancing the upper register. The tuned anode is connected via the usual condenser and grid leak to a DEH.610 anode-bend detector. The anode circuit of the rectifier contains a 0.0002 mfd. by-pass condenser, a radio-frequency choke of low self-capacity, and a resistance of 100,000 ohms.⁴ The coupling between the detector and the pentode power valve is resistance-capacity. The grid leak consists of 6×0.5 megohm units, and this can be tapped to vary the intensity.⁵ Care should be exercised in wiring these leaks to avoid capacity.

The output from the pentode is taken via the usual condenser-inductance filter circuit to a coil-drive loud speaker of the type I described previously in this journal.⁶ The moving coil has 2,500 turns, and the magnet is of good soft dynamo steel, which on 200 volts gives a flux-density of over 9,000 lines per square centimetre in the air gap. I mention this because I have found by measurement that the *output* with a cast-iron pot is only one-quarter of this value, and is liable to create an erroneous impression, because experimenters will be prone to over-drive the pentode in order to get adequate intensity. The result is "prickly" reproduction, due to blasting and grid current. Battery filter

⁴ This has been kept low to minimise feed back and the shunting effect of capacity on the higher frequencies. However, if two 0.25 megohms grid leaks are handy they can be tried separately in series or in parallel.

⁵ One 2 megohm leak will do, but this means intensity control on the aerial tuning which is not good practice, although often used even in the best circles.

⁶ April 15th, 1927.

ERRATA.—The ordinated in Fig 7 and "anode + screen" current. The explanatory matter beneath Figs. 9 and 10 should be interchanged.

THE FACTS ABOUT THE PENTODE.

1. The pentode is a power valve of high magnification factor, large internal resistance, and high conductance.
2. For equal input voltages the output from a pentode far exceeds that from a power triode.
3. With a coil-drive loud speaker using 1,000 turns on a 2-inch former, the current with the pentode for constant input volts, is substantially constant throughout the acoustic range.
4. A coil having 2,500 turns can be used with a pentode without sacrificing quality to any serious extent. The power output is then about 6 times that with a coil of 1,000 turns.
5. Care must be exercised to reduce the external capacity of the valve holder and its connections to a minimum. This applies especially when the impedance of the load or loud speaker is relatively large, for the magnification of the pentode will be correspondingly large. There will, therefore, be a capacity input impedance which attenuates the higher audio frequencies.
6. For substantially constant current through the coil at all frequencies, the number of turns on a 2-inch former should not exceed 2,500. A greater number of turns means greater inductive reactance and a reduction in current at the higher frequencies.

Getting the Most from Accumulators.

If all listeners were to follow the advice given by Mr. L. F. Summers, A.M.I.E.E., in a recent lecture before the North Middlesex Radio Society, they could depend upon an adequate return for the cost of their accumulators. Mr. Summers addressed his remarks specially to those who do not get the maximum amount of service from their accumulators before they qualify for the dustbin.

After describing the process whereby an accumulator discharges, the lecturer emphasised the importance of re-charging the battery directly it is 80 per cent. run down. With regard to accidental short circuits, he pointed out that these are not harmful provided that (a) the temperature does not rise above 100-110 deg. F.; and (b) the battery is put on charge at once. "When

CLUB NEWS.

it is realised," said Mr. Summers, "that car-starting batteries are frequently called on to deliver 200 amps. and yet last for many years, it will be realised that the secret of their longevity lies in the fact that they are charged immediately after discharge."

Hon. Secretary: Mr. E. H. Laister. "Endcliffe," Station Road, N.21.

Moving Coil Theory and Practice.

The theory and operation of the moving coil loud speaker was the subject of a lecture given recently by Mr. E. F. Handley before Slade Radio (Birmingham). The points dealt

arrangements were incorporated for each valve, as will be evident from the lower part of the diagram of connections (Fig. 18). Care was exercised with the wiring and disposition of the apparatus to avoid unwanted coupling of any form. Anti-capacity holders were used, and external capacity between the anode and control grid leaks of the pentode reduced to the least practicable amount. Arrangements were made for connecting two pentodes in parallel with a minimum of capacity external to the valves.

Using a battery of 200 volts and series resistances to the pentode, thereby obtaining 150 volts on its anode, the quality was as good as anything I have heard from any loud speaker, whilst the intensity by comparison *with the same input* to a triode was somewhat staggering. On 2LO at 5 miles' range it was only possible to use $\frac{1}{3}$ of the maximum voltage input to V_3 . This, however, depends on the aerial. Of course, we shall get used to this loudness in time, and again clamour for Australia or Mars (!) on a peanut valve.

With two pentodes in parallel there was a distinct reduction in the upper frequencies, but the reproduction was by no means poor. The attenuation of the higher frequencies (noticeable in words ending with the letter "s") may have been due in part to feed-back, as explained in Part II. Another reason is the decrease in valve resistance. With two valves in parallel, this resistance would be about 15,000 ohms, which is equal to the inductive reactance of the moving coil at 6,000 cycles. This means a reduction in coil current relative to that obtained at 300 cycles or thereabouts, where the coil reactance is negligible. The reed-drive speakers were also tested. They seemed a little happier in the top register than before, but apart from this there was little difference in performance as compared with the previous tests. On the other hand, by connecting the screen and anode together and using the valve as a triode, the results were comparable in quality with those obtained with a triode of the D.E.5A class. Owing to the higher "m" value, a smaller signal was required for the pentode used as a triode. In using the pentode in the orthodox manner the reed type might be matched with the aid of a transformer.

with included: Motion of Coil in Radial Field, Theory of the Diaphragm, The Use of the Baffle, Transmission Losses, and The Advantages of a Re-entrant Cone.

L.F. amplification received attention, and the lecturer dealt with the various types of output stage. The lecture was accompanied by a convincing demonstration with a moving coil loud speaker designed and constructed by Mr. Handley.

Hon. Secretary: Mr. R. Clews, 52, St. Thomas Road, Erdington, Birmingham.

H.F. Coupling.

At to-morrow's meeting, at 8.15 p.m., of Slade Radio (Birmingham), Mr. J. W. Walker will lecture on "Coupling: High Frequency Valves."



By Our Special Correspondent.

Listeners' Hopes.—Teaching Talks Technique.—A Panorama of Pastimes.—Amateur Transmitter Tries Broadcasting.—Bank Holiday Programmes.

A New Listeners' Organisation.

As a sequel to the recent criticisms of B.B.C. programme policy, it is, I hear, highly probable that one of our big national "dailies" will shortly launch a listeners' league to champion the rights of licence holders.

Is the Public Really Desperate?

Members of Parliament started the latest craze for criticism, but I am not persuaded that the public is nearly so desperate as many newspapers and journals would have us believe. Few of us are completely satisfied with "the common round, the trivial task" (or talk), but we are growing more tolerant, possibly because, at the back of our minds, there dwells the thought of that beneficent regional scheme with its promise of three or four programmes to grumble at instead of two.

Trying it on Friends.

An excellent plan for teaching the art of talking into the microphone will be experimented with at the British Association meeting in Glasgow on September 11th. The B.B.C. will erect a model studio in the University to enable members of the Association to demonstrate to their friends how to hold the listener's attention. The friends will listen to the performance during the morning session in loud speakers. I hope, however, that he learned professors will remember that it is easier to hold the attention of experts (who also happen to be friends) in the bright morning hours, than of ordinary laymen who have to listen to similar talks after a day's work.

Wireless Display at B.A. Meeting.

A new feature at the B.A. meeting will be a demonstration, staged by the B.B.C., of wireless receiving apparatus designed for the use of schools and adult study groups.

Sir John Reith will open a discussion entitled "Wireless in the Service of Education."

Family Pastimes: Then and Now.

Ideas for the National Radio Exhibition are already under discussion at Savoy Hill. One rather interesting scheme, which will probably materialise in the B.B.C. section, is a panorama of family entertainment through the ages, beginning with the paleolithic man crack-

item than for any other, for several months past.

It is not unlikely that the jovial Co-optimist leader will be a prominent figure in the autumn programmes.

Amateur Transmitter Does His Best.

"Peter Calling" is the title of a play, described in the programme as "A Wireless Mystery in Three Scenes," which is to be broadcast from Manchester tomorrow evening (Thursday). One of the chief characters in this enigmatical drama is one called "Peter," who is set down on the programme to be played by ???

Without giving the game away, it may be said that the action is amusingly concerned with the complications that may follow when an amateur transmitter tries his hand. The play will be presented by the Station Repertory Players.

Next: A Talk on Black Beetles?

"People do not—" says the vice-chairman of the Wireless Retailers' Association, "—people do not want to hear about the black beetles of North Africa."

This is a dangerous remark, and I hope it never reaches Savoy Hill. It reminds one of the poor persecuted saint who, addressing his torturers, said: "In the name of Charity, spare me the eleven-pronged rib tickler." Whereupon they said: "Splendid: we hadn't thought of that. Just hold out your ribs."

Listening to Work.

A journalist has been suggesting several "stunts" which the B.B.C. might try during the next few weeks. The best idea—and this is where a touch of genius comes in—is that listeners should be enabled to hear a Lancashire town going to work. This certainly ought to wake us up; indeed, we should miss it if we failed to rise early. But the idea need not be confined to the activities of Lancashire. To hear anybody, anywhere, having to work during our own moments of leisure would be very satisfying. The bricklayer condemned to work during the lunch-hour, the all-night train-driver dreaming

FUTURE FEATURES.

London and Daventry.

AUGUST 1ST.—"Good Breeding," a play by C. A. Lewis.

AUGUST 4TH.—The Southern Command Tattoo, relayed from Tidworth, Hants.

Daventry Experimental 5GB.

AUGUST 2ND.—Symphony Concert from Bournemouth.

AUGUST 3RD.—"Handley's Manœuvres," produced by Tommy Handley.

Cardiff.

JULY 31ST.—"Much Marole," a Musical Comedy by Miriam Pritchett.

AUGUST 4TH.—"Wait for It," a Revuette by Donald Davies.

Manchester.

JULY 31ST.—The Kingsley Prize Concert Party.

AUGUST 2ND.—Orchestral Concert from Buxton.

Glasgow.

AUGUST 4TH.—The Powdered Players Concert Party.

Aberdeen.

JULY 31ST.—The Thackit Hoosie.

Belfast.

AUGUST 3RD.—Popular Opera.

ing jokes and heads in the household cave, and finishing with a modern licence holder listening to 5GB. Query: Who is the happier?

A "Surprise" Success.

Davy Burnaby and his fellow artists hit the bull's-eye with their "surprise" turn the other Friday, to judge from the correspondence received at Savoy Hill, there being more letters regarding this

of a soft bed, the early morning milkman—all of these and a hundred others would have plenty to say even if limited to five minutes.

A B.B.C. Emigrant.

Not everybody agreed with the Postmaster-General's recent description of the B.B.C. as the envy of other nations, but there is no doubt that a high valuation is placed on individual members of the staff by organisations overseas.

Mr. Arthur Burrows ("Uncle Arthur") was one of the first of the Savoy Hill family to receive international recognition, and he still holds the onerous post—to which he was appointed years ago—of Secretary to the Bureau Internationale de Radiophonie at Geneva. The next was Mr. Eric Dunstan, who is now managing the affairs of the Indian Broadcasting Company; and the latest emigrant is Mr. R. D. Green ("Uncle Bob"), of the Leeds Bradford station. Mr. Green left Southampton on Thursday last for South Africa, having been appointed director of the Johannesburg broadcasting station.

Why Not a Month's Holiday?

"Sir,—There can be little doubt left now as to the cause of the present atrocious weather. Would not the broadcasting companies give themselves a holiday for, say, a month, and so give the farmers a chance to get in their hay? This would mean a sacrifice on their part, but even the most optimistic of us can only hope for a very fair harvest as it is.

—Yours, etc., A. E. Madoc Jones.

3, Victoria Terrace, Beaumaris,
July 5th, 1928."

—A letter to the Editor of the "Liverpool Post."

Things we Should Like to Know.

What has become of "Uncle Joey," the Savoy Hill parrot.
When he intends to take part in the Children's Hour.
Whether he still spends his days in the Talks Department.
Whether he has been literally bored to death.

A Profane Bird.

Better a silent parrot, however, than a profane cockatoo of the sort that created a panic in Melbourne a few weeks ago. According to the "New Zealand Herald," Mr. Rupert Cooke, a Melbourne hotel proprietor, lent his cockatoo to a local wireless amateur for a test transmission. The bird, which was 28 years old, was considered old enough to possess a sense of propriety, but the microphone revealed some unexpected traits in his character.

Oaths with Splendid Clarity.

The amateur describes the attempt thus:—

"We commenced about 2.15 o'clock. With his first oath Mr. Cooke grabbed the bird by the throat. He became quiet and we started again, hoping that the first expletive was only a slip. He

offended again twice, and finally it became necessary for me to make a very loud noise into the microphone, while Mr. Cooke closed down the cockatoo by force. Unfortunately the test was too good. The clarity was such that I have already received reports from more than 50 people saying that they heard distinctly every word the bird uttered. That is unfortunate."

Bank Holiday Fare.

The true bank holiday spirit is to be propagated by 2LO and 5XX on the evening of August 6th. The revels will begin

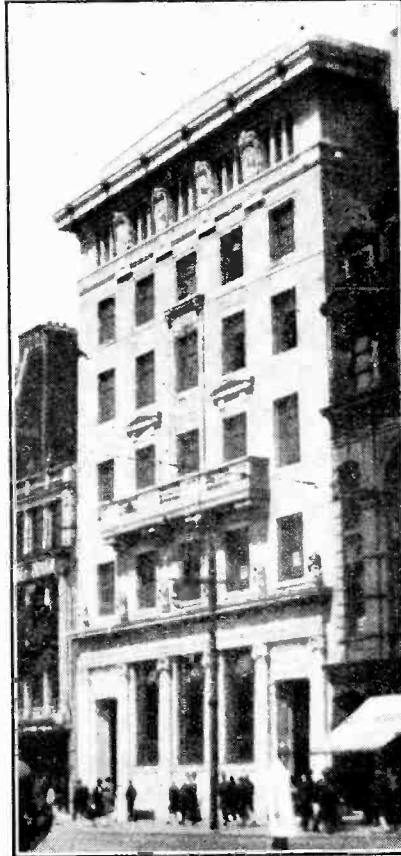

"BROADCASTING HOUSE." The new Manchester headquarters of the B.B.C., known as "Broadcasting House," in Piccadilly. Structural alterations are now in progress, and include the provision of a large studio with a gallery for the audience.

with a performance by the Band of London, a new combination brought together by Percy Gayer. Later in the evening Mabel Constanduros is presenting a new Zoo sketch of her own composition. We shall then hear excerpts from "So this is Love" relayed from the Winter Garden Theatre, and the evening will wind up with dance music by the B.B.C. dance orchestra, Alfredo and his band, and the New Princes Dance Orchestra.

'Energy and Albert on the Beach.

Meanwhile 5GB listeners will be carried away in spirit to the seaside for a popular Bank Holiday programme. The Band of the 1st Bn. Suffolk Regiment will play, while the Imperial Scots Concert Party will give a typical seaside entertainment.

Molly Hall and Stuart Vinden will take part in a sketch entitled "It's so Bracing," while Emma, 'Energy and your Albert will enjoy themselves on the beach in true British fashion.

A First Appearance.

A broadcast by Harry Weldon is now definitely fixed, and he will appear in the 2LO programme on July 31. This will be his first broadcast.

In the same programme are Julian Rose and Nick Adams, who are probably the funniest comedians at present appearing in public in Jewish cross-talk.

Porridge or Haggis?

Listeners generally took a keen interest in the first of the B.B.C. controversial debates recently when Sir Ernest Benn and Mr. Maxton met in argument before the microphone. Of quite a different type, but if anything more controversial in character, is the debate which Aberdeen promises its listeners on July 27th. On that evening the momentous national question, "Do Scotsmen thrive best on porridge or haggis?" will be thoroughly thrashed out in the studio with "George," of Aberdeen, and Willie McCulloch, of Paisley, as the protagonists. These are two of the most amusing broadcasters in Scotland.

Tearless Motoring.

Frank Denton and Phyllis Panting will broadcast a sketch on 2LO on July 30, entitled, "Motoring Without Tears."

Wireless in a Leper Colony.

If there is one place where broadcasting is thoroughly appreciated it is surely the leper island of Makogai, one of the most beautiful but lonely of the Pacific Islands. The island is nine miles from Levuka, Fiji, but until the instalment of a wireless set a few months ago it was practically cut off from the outside world, only being visited at rare intervals by boats from Fiji or New Zealand.

Last August, writes a correspondent, a five-valve set costing nearly £70 was presented to the island by the Combined Retail Soft Goods Charity Club of New Zealand, and this set has since done much to brighten the lives of the 450 lepro patients, which include Fijians, Samoans, Tongans, Indians, Chinese, Soloman Islanders, Cook Islanders, New Zealand Maoris, and some Europeans. The set has been named "He Reo Tawhiti, meaning "Voice from a distance." Our four valves it can easily pick up all Australian and New Zealand stations, while the fifth gives clear reception of many American ones.



The Editor does not hold himself responsible for the opinions of his correspondents.

Correspondence should be addressed to the Editor, "The Wireless World," Dorset House, Tudor Street, E.C.4, and must be accompanied by the writer's name and address.

SPARK INTERFERENCE.

Sir,—With reference to the letters of "Unsatisfied," Mr. Ernest Freedley, and others in regard to spark interference, there are one or two points which they all seem to overlook.

First, that Morse transmissions of whatever nature have priority over any other wireless service. The broadcast service is a very junior and unimportant service compared with the exchange of messages in Morse from ship to ship, ship to shore, etc. By this I do not wish to under-rate the value of broadcasting.

Secondly, the amount of money involved in suddenly modernising all the spark sets fitted on ships trading into European waters would be simply stupendous. In this connection Mr. Ernest Freedley's suggestion of proportioning part of the licence fees is certainly a good one, but it fails in so far as it would be applicable to British ships only, and my own personal experience is that 85 per cent. of the interference on the broadcast band is from a foreign source.

Mr. Ernest Freedley is evidently under the impression that the various shipping companies actually own the wireless apparatus on their vessels. While this is true in a few cases, the majority enter into an agreement whereby apparatus is supplied on a rental and maintenance basis. Therefore it stands to reason that it would be impossible for a wireless company to make any sudden alteration of apparatus without involving considerable expenditure. It must be taken into account that the art of wireless has advanced so rapidly in the last few years that it would not be possible for any big company to suddenly scrap apparatus which must be considered as an asset for some time to come. The process of substituting up-to-date apparatus must, therefore, be extended over a considerable period.

For the time being I am afraid we shall have to grin and bear it and look forward to the time when international regulations compel ships and shore stations to use apparatus and wavelengths which do not interfere with broadcast reception.

As an ex-operator of considerable experience, I should like to make the suggestion of stricter supervision over existing spark sets, as many operators, to my own personal knowledge, are inclined to tighten their aerial coupling under the mistaken impression of greater radiation efficiency. This is the very worst thing they could do from the point of view of the broadcast listener.

In conclusion, may I express the hope, that seeing both points of view the spirit of co-operation will, perhaps, go a long way towards decreasing this bugbear of Morse interference.

ARTHUR C. WEBB (G 6WQ).

Westcliff-on-Sea.

June 26th, 1928.

STEEL PANELS.

Sir,—It has often occurred, while studying the pages of your very interesting and instructing paper, that it is strange, in this time, when everyone is using metal panels, that no one seems to use the cheaper metals.

I have constructed a receiver in which I use a panel made of planished steel. In use I find that it is in every way equal to a copper or aluminium one, and it cost a few pence.

The bluish grey of the metal makes a very pleasing combination with most woods, and the ebonite fittings, such as dials, etc., look far better than they do when mounted on the rather cold-looking aluminium.

The metal is sold in sheets of about 1/32 in. thickness, so it is

necessary to place some backing behind in order to give sufficient support to the components. A piece of three-ply wood which, after baking in an oven to expel all moisture, was well shellacked and cut the same size as the panel, and the components and angle brackets screwed through metal and wood secured the two together.

I am sure that your readers would be glad to know of this tip, and would be delighted at the appearance of the finished job. Wishing you every success with your paper, and looking forward to the next issue.

Swansea.

KENNETH A. DAVIS (BM/ZHPD).

July 12th, 1928.

RECEPTION OF 5SW

Sir,—The letter from your correspondent in Lahore dated June 9th raises a point on this subject which interests a very large number of listeners in the Empire overseas.

He reports good reception in the Punjab—about equal to that of PCJJ. I understand that reception is also reported as good as from S.E. Europe, S. Africa, India generally, and Australasia. It is most certainly extremely poor in a S.W. direction.

My own short-wave receiver is situated on longitude 60° W., about 3,000 miles S. of New York, i.e., about 700 miles only N. of the Equator. There PCJJ is received on the loud speaker, whereas 5SW is never intelligible on the loud speaker, and only very rarely on headphones. That this is not the fault of the set is evident from the fact that PCJJ is received on the loud speaker at satisfactory volume, and that KDKA (all three wavelengths), WGY (both wavelengths), and WLW are all received at a volume equal to that of 2LO on good 1-v-2 sets with which I am familiar at various points on the 40-50-mile band round London—S.E., S., and W.

If 5SW really is an efficient station, one is forced to the conclusion that its aerial is at least first cousin to a beam aerial.

I understand that the B.B.C. have denied that it has a directional aerial in this sense. If this is true, it is quite useless to pretend that it is an efficient station, since the conditions that apply to reception of it at 4,000 miles S.W. apply equally to PCJJ. 60° WEST.

THE ELECTRICITY SUPPLY RAMP.

Sir,—I was very interested to read your editorial comments on this matter in to-day's issue.

I recently took the matter up with the local Corporation Electricity Department, and was informed that they had decided absolutely to refuse to replace any radio apparatus rendered obsolete on account of a change over from D.C. to A.C. The only exception they make is when the apparatus is used in connection with the consumer's business (battery charging, etc., I assume).

This situation seemed very unsatisfactory and extremely unfair, since I have never asked for A.C., being, in fact, fairly happy with the D.C. supply. The Corporation advertises that "Electricity Saves More than it Costs," and in many ways tries to get one to use current. Then, for its own purposes, it puts one to considerable needless expense.

In fairness to the local Corporation, I must add that they have agreed to bear the cost of adapting certain other apparatus, which I have in use, to A.C. On radio apparatus, however, they will not move.

Wolverhampton.

C. S.

July 11th, 1928

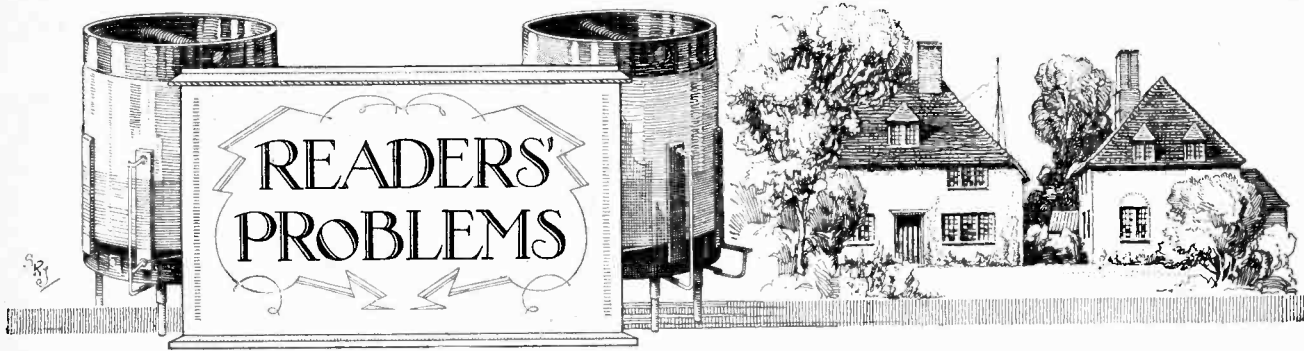

"The Wireless World" Supplies a Free Service of Technical Information.

The Service is subject to the rules of the Department, which are printed below; these must be strictly enforced, in the interest of readers themselves. A selection of queries of general interest is dealt with below, in some cases at greater length than would be possible in a letter.

A Misleading Voltage Reading.

My receiver has a choke filter output, and I find that when a voltmeter is connected across the accumulator H.T. battery it shows a full reading of 160 volts, but if I join it between the anode terminal of the valve and negative H.T. the indicated voltage falls to 70, so I am losing 90 volts in the choke. Does this indicate that this component is unsuitable for the circuit?

M. R. L.

You have fallen into the common error of neglecting the fact that when carrying out measurements in this way a large proportion of the voltage may be absorbed in the choke, and you are probably getting a misleading indication, particularly if your meter is of low resistance; a reading taken in this way would show the actual voltage on the anode only if the meter passed exactly the same current as the valve. For further information on this subject we would refer you to an article, "The Eliminator Output," in our issue of May 2nd, 1928.

An Improvised Megger.

I am told that it is possible to make comparative tests of insulation resistance (of many megohms) with the help of a valve. Can you give me any information on this subject, bearing in mind the fact that my measuring equipment is limited to a voltmeter and a milliammeter? I do not expect highly accurate quantitative results, but merely an indication.

S. L.

There are several ways of using valves in testing for insulation, but we suggest that the simplest way of obtaining a rough and ready indication is to use the circuit shown in Fig. 1. In setting it up, due precaution should be taken to ensure that the insulation resistance of the apparatus is above suspicion.

The operation is not difficult to understand. Assuming the "test" terminals to be perfectly insulated, it will be understood that the valve grid is at zero potential. Now if these terminals are joined together, a negative grid bias

from the battery will be applied, with the result that anode current (as indicated by the milliammeter) will decrease. The same effect will be noticed if the circuit is completed through a resistance, but the falling-off in current will be noticeably less when this becomes comparable

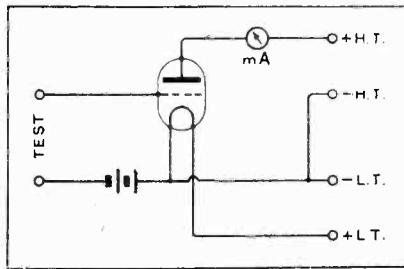

Fig. 1.—Testing for insulation: leakage in the external circuit is indicated by change in anode current.

RULES.

- (1.) Only one question (which must deal with a single specific point) can be answered. Letters must be concisely worded and headed "Information Department."
- (2.) Queries must be written on one side of the paper, and diagrams drawn on a separate sheet. A self-addressed stamped envelope must be enclosed for postal reply.
- (3.) Designs or circuit diagrams for complete receivers cannot be given; under present-day conditions justice cannot be done to questions of this kind in the course of a letter.
- (4.) Practical wiring plans cannot be supplied or considered.
- (5.) Designs for components such as L.F. chokes, power transformers, etc., cannot be supplied.
- (6.) Queries arising from the construction or operation of receivers must be confined to constructional sets described in "The Wireless World" or to standard manufacturers' receivers.

Readers desiring information on matters beyond the scope of the information Department are invited to submit suggestions regarding subjects to be treated in future articles or paragraphs.

in value to the incidental resistance across the valve. An adequate discussion of this point cannot be entered into here, but, generally speaking, you may take it that an insulation resistance of many megohms is indicated when there is no perceptible change in anode current when the test is applied.

Series Condensers.

With reference to your recent article, "Safety and the Mains," I should be glad to know if the tuning range of my receiver will be appreciably altered by fitting series condensers in the aerial and earth leads.

W. P. M.

If your receiver has a tuned aerial circuit, you will find that the condenser setting will not be appreciably changed if the series condensers are of 0.01 mfd. or larger. With an "untuned" coupling the capacity could be still further reduced without any noticeable alteration.

A Double Fault.

My "Everyman-Four" receiver will not quite tune up to the wavelength of 5GB, although this station is just heard when both condensers are set at maximum. It is noticed that signals become weaker when I withdraw my hands from the dials. The coils are commercially made to "Wireless World" specification, and the condensers are of 0.0003 mfd., as specified.

V. S.

We think that two separate faults are indicated by your description. In the first place it is certain either that the secondaries of the coils have an insufficient number of turns or that the condensers are below their rated capacities. As far as the coils are concerned, you can check this by counting turns. Secondly it appears that you are increasing the capacity across the windings by placing your hand in proximity to the dials, and this suggests that the moving plates and framework of the condensers are not connected to the earth side of the circuit as they should be.